

Travelling Merchant: \_\_\_\_\_

# DATASHEET

Standard: **DPAB12000001**

\_\_\_\_\_

\_\_\_\_\_

Plot			The Label
Drew	Audited	Approved	Stamp, please! Thanks!
Date: 2017.10.20			

## Guangdong Dapu Telecom Technology Co.,LTD

Bldg13-16,.N.Ind.Zone,SSL Industry Park, Dongguan City, Guangdong Province, China

TEL: 0086-0769-88010888 FAX: 0086-0769-81800098



## 1、 Electrical Parameters

MODEL: DPAB12000001							
No.	Parameters	SYM.	Electrical Spec.				Notes
			Min.	Typ.	Max.	Units	
1	Nominal Frequency	FL	12.00			MHz	
2	Oscillation Mode	-	Fundamental				
3	Load Capacitance	LC	13			pF	
4	Frequency Tolerance	-	±30			× 10 <sup>-6</sup>	at 25°C ±3°C
5	Frequency Stability	-	±30			× 10 <sup>-6</sup>	with working temperature Reference to 25°C
6	Operating Temperature	-	-20~70			°C	
7	Insulation R	-	500			MΩ	100VDC
8	Aging	-	3			× 10 <sup>-6</sup>	@25°C 1st Year
9	Drive Level	DL	100			uW	
10	Resonate Resistor		60			Ω	Max
11	Shunt Capacitance C0	C0	7			pF	
12	Storage temperature range		-55~125			°C	
13	ESD Level	Human Body Model,class2: 2000V to 4000V; ANSI/ESDA/JEDEC JS-001-2010					
		Machine Model, class B: 200V to 400V; ANSI/ESDA/JEDEC JS-001-2010					
14	Moisture Sensitivity Level	Level 2					
15	Vibration	Test Condition: 0.75mm ;acceleration:10g;10Hz~2000Hz, one cycle per 30 min, test 2 hour. (3 times for each 3 directions X ,Y , Z). IEC 68-2-06 Test Fc.					
16	Shock	100g; 6ms; half sine wave (3 times for each 3 directions X ,Y , Z),IEC 68-2-27 Test Ea/Severity 50A.					



## 2、Mechanical Structure(mm)

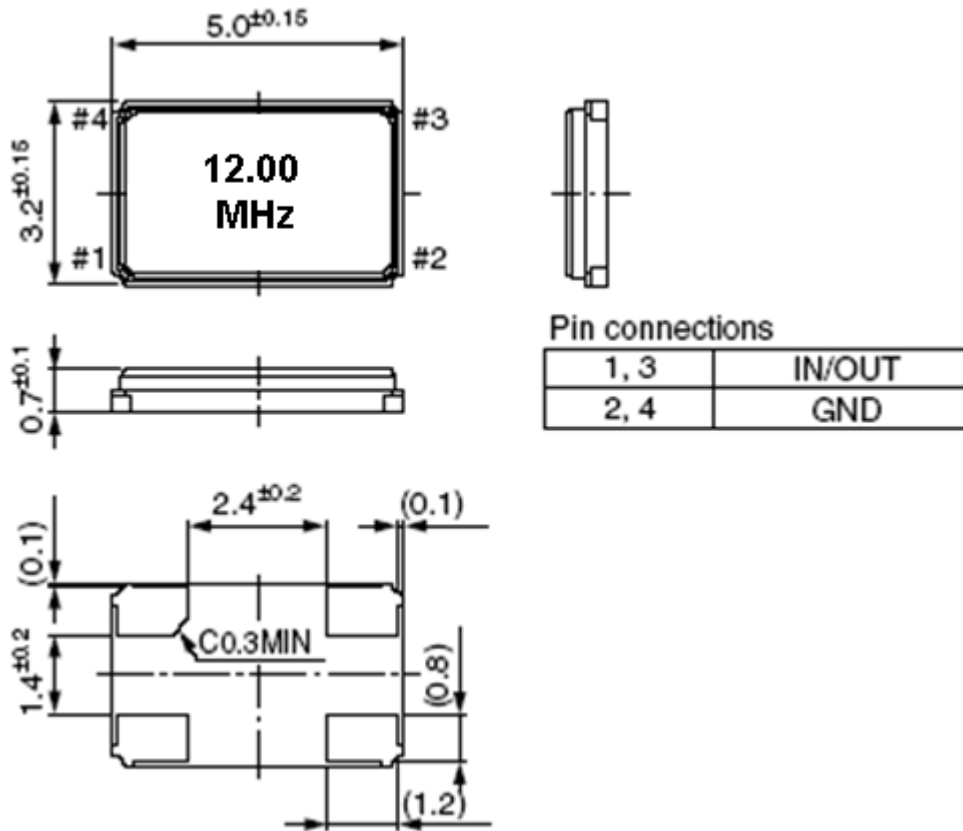

**Note1:** Tolerance  $\pm 0.2$  mm



### 3、Reflow Soldering Curve (RoHS)

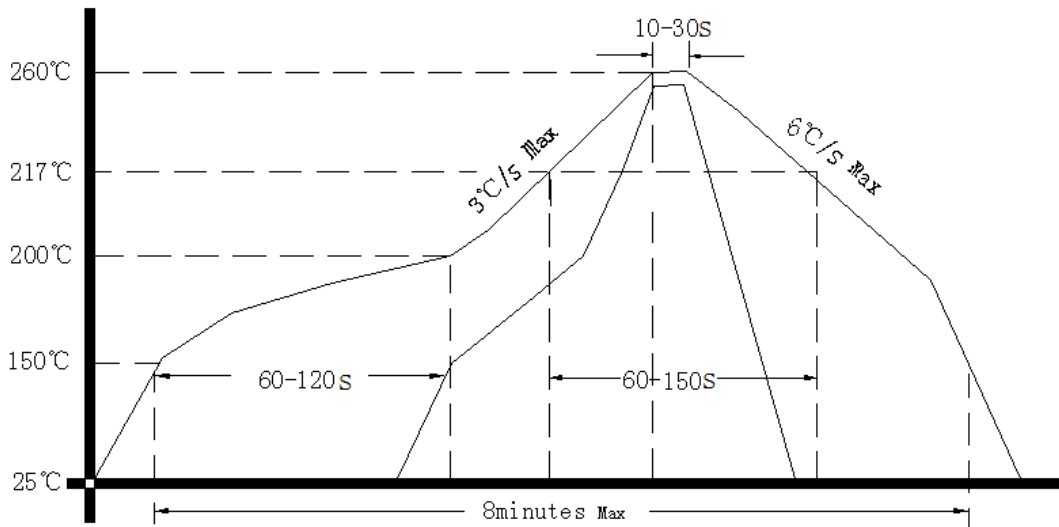

### 4、Package: Tape & Reel (mm)

