

Travelling Merchant: _____

DATASHEET

Standard: **O55F-M468-10.00MHz**

P/N: _____

Plot			The Label
Drew	Audited	Approved	Stamp, please! Thanks!
Date: 2020.03.04			

Guangdong Dapu Telecom Technology Co.,Ltd

Bldg13-16,.N.Ind.Zone,SSL Industry Park, Dongguan City, Guangdong Province, China

TEL: 0086-0769-88010888 FAX: 0086-0769-81800098



1. Electrical Parameters

MODEL: O55F-M468-10.00MHz						
Item	Description	Parameters			Unit	Test Condition
		Min.	Typ.	Max.		
Output	Frequency	10.00			MHz	
	Output Waveform	Sine wave				
	Level	9	11	13	dBm	
	Load	50			Ω	
	Harmonics Suppression			-30	dBc	
	Spurious Suppression			-60	dBc	
Frequency Stabilities	Frequency Tolerance vs. Operating Temperature Range	-1		+1	$\times 10^{-9}$	T_A varied from -40°C to 80°C , measurement referenced to frequency observed with $f_{\text{ref}} = (f_{\text{max}} - f_{\text{min}}) / 2f_0$, $V_{\text{cc}} = 15\text{V}$, $O_{\text{load}} = 50\Omega$. temperature variable speed less than 2°C per minute.
	Initial Frequency Tolerance	-0.05		+0.05	$\times 10^{-6}$	Measurement referenced to frequency observed with $T_A = 25^{\circ}\text{C}$, $V_{\text{cc}} = 15\text{V}$, $V_c = 3.6\text{V}$ and after 15 minutes of operation, within 30 days after ex-works.
	Frequency Tolerance vs. supply voltage	-0.5		+0.5	$\times 10^{-9}$	measurement referenced to frequency observed $T_A = 25^{\circ}\text{C}$, V_{cc} varied from 14.25V to 15.75V, $V_c = 3.6\text{V}$, $O_{\text{load}} = 50\Omega$.
	Frequency Tolerance vs. Load	-0.5		+0.5	$\times 10^{-9}$	5% Load Change Measurement referenced to frequency observed with $T_A = 25^{\circ}\text{C}$, $V_{\text{cc}} = 15\text{V}$, $V_c = 3.6\text{V}$, $O_{\text{load}} = 50\Omega$.
	Aging Tolerance Per Day	-0.2		+0.2	$\times 10^{-9}$	V_{cc}, V_c, T_A constant Measurement referenced to frequency observed with $T_A = 25^{\circ}\text{C}$, $V_{\text{cc}} = 15\text{V}$
	Aging Tolerance 1Year	-0.02		+0.02	$\times 10^{-6}$, $V_c = 3.6\text{V}$, $O_{\text{load}} = 50\Omega$ and after 30 days of operation.
Power Supply	Supply Voltage	14.25	15	15.75	V	
	Current Consumption			400	mA	@ 25°C
	Current Consumption during warm up			1000	mA	
	Warm up time			15	min	@ 25°C



Voltage Control Characteristics	Frequency Tuning Range			-0.3	$\times 10^{-6}$	$V_c=0V$. measurement referenced to $V_c=3.6V$.
		-0.05		+0.05	$\times 10^{-6}$	$V_c=3.6V$. measurement referenced to exactly 10.00MHz.
		+0.3			$\times 10^{-6}$	$V_c=8V$. measurement referenced to $V_c=3.6V$.
	Linearity			10	%	
	Slope	Positive				
	Input Impedance	100				K Ω
Phase Noise	Phase Noise		-130	-120	dBc/Hz	10Hz
			-145	-135		100Hz
			-150	-145		1KHz
			-155	-150		10KHz
			-155	-150		100KHz
			-155	-150		1MHz
Environmental Conditions	Operable Temperature	-40		+80	$^{\circ}C$	
	Storage Temperature	-55		+105	$^{\circ}C$	
	ESD Level	Human Body Model, class2: 2000V to 4000V; ANSI/ESDA/JEDEC JS-001-2010.				
		Machine Model, class B: 200V to 400V; JEDEC JESD22-A115C.				
	Moisture Sensitivity Level	Not humidity sensitive.				
	Vibration	Test Condition: 0.75mm ;acceleration:10g;10Hz~500Hz, one cycle per 30 min, test 2 hour. (3 times for each 3 directions X , Y , Z), IEC 68-2-06 Test Fc.				
Shock	50g; 11ms; half sine wave (3 times for each 3 directions X , Y , Z),IEC 68-2-27 Test Ea/Severity 50A.					
Full Package Storage	Relative humidity (%)	20% ~70%				
	Temperature ($^{\circ}C$)	-10~35 $^{\circ}C$				



2. Mechanical Structure (mm)

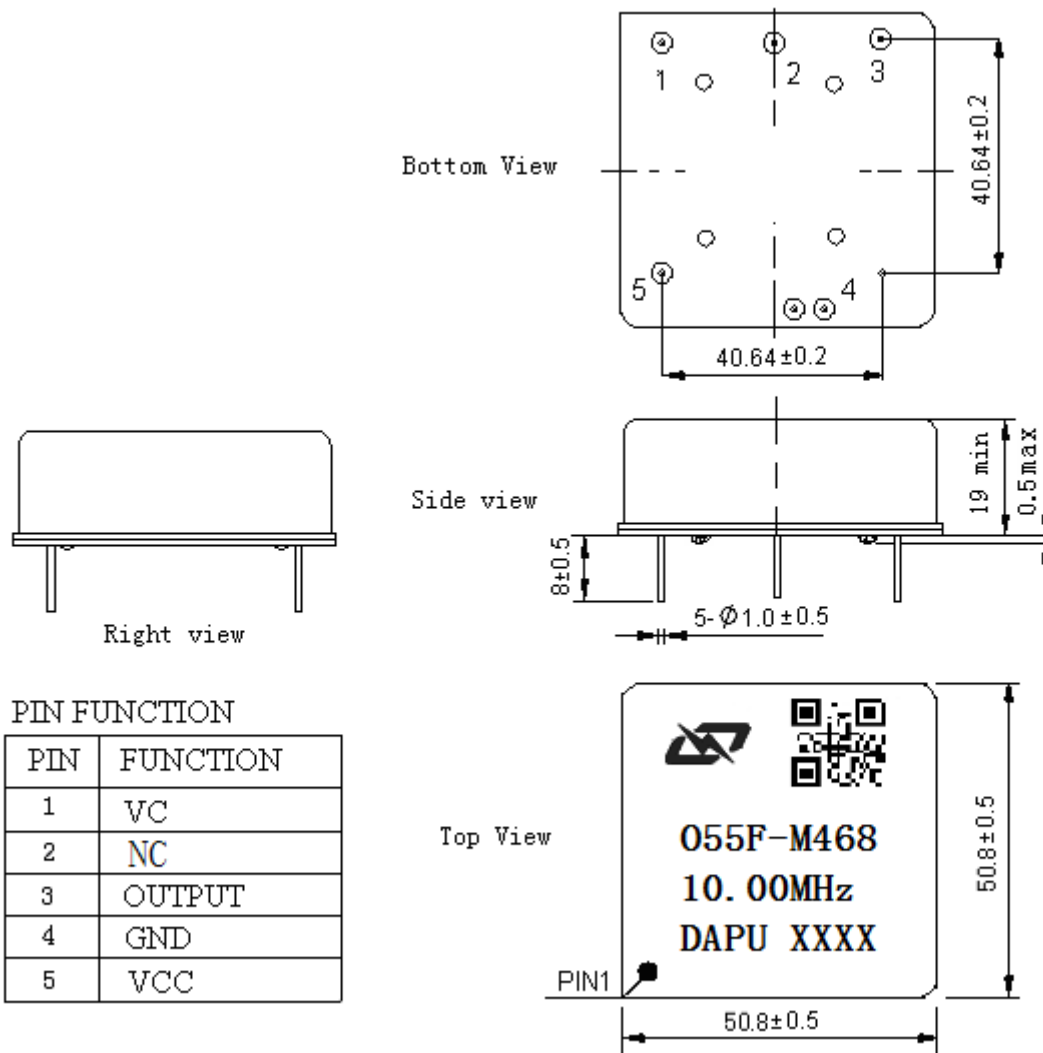

PIN FUNCTION

PIN	FUNCTION
1	VC
2	NC
3	OUTPUT
4	GND
5	VCC

- Note1:** Tolerance ± 0.20 mm without mark
- Note2:** The first two xx representative: week
After two xx representative: year
- Note3:** Referential weight 54.8g
- Note4:** NC is not connect



3. Test Circuit

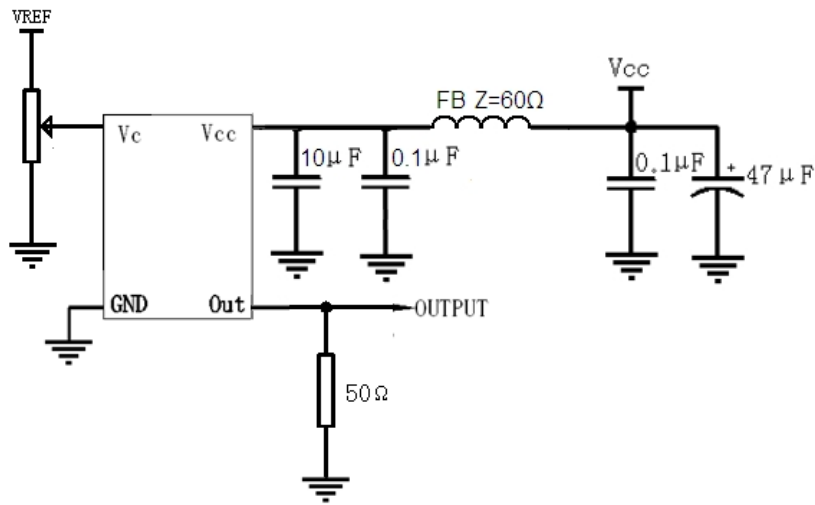

4. Reflow Soldering Curve (RoHS)

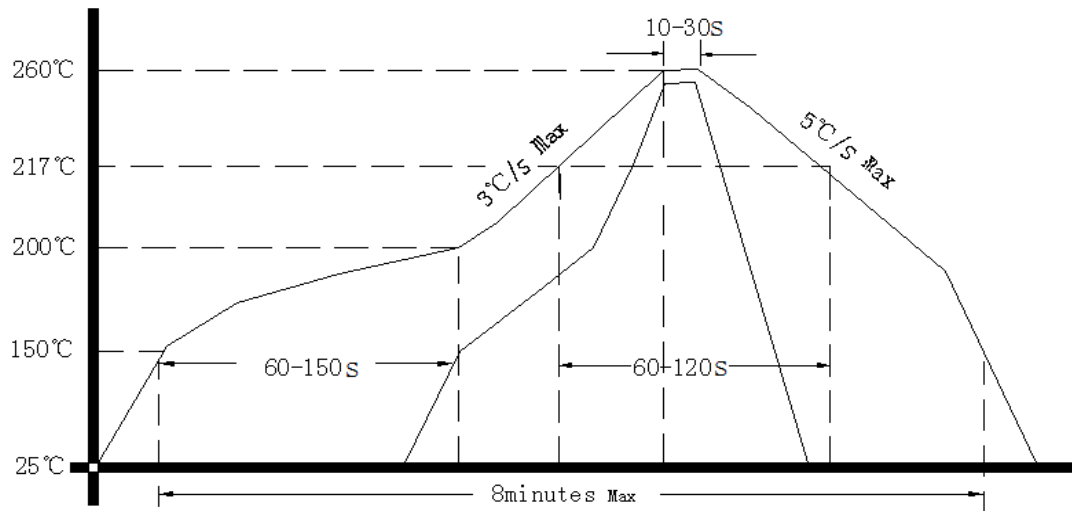

5. Package(mm)

