

Travelling Merchant: _____

DATASHEET

Standard: DP7C32768001

Plot			The Label
Drew	Audited	Approved	Stamp, please! Thanks!
Date: 2019.12.02			

Guangdong Dapu Telecom Technology Co.,Ltd

Bldg13,.N.Ind.Zone,SSL Industry Park, Dongguan City, Guangdong Province, China

TEL: 0086-0769-88010888 FAX: 0086-0769-81800098



1、Electrical Parameters

MODEL: DP7C32768001							
No.	Parameters	SYM.	Electrical Spec.				Notes
			Min.	Typ.	Max.	Units	
1	Nominal Frequency	FL	32.768			KHz	
2	Frequency Stability	-	-50		+50	ppm	Include:25°C tolerance ±20ppm,operating range, input voltage change, aging, load changed, shock and vibration)
3	Operating Temperature	Topr	-40	~	85	°C	
4	Storage Temperature	Tstg	-55	~	125	°C	
5	Supply Voltage	V _{DD}	2.97	3.3	3.63	V	
6	Input Current	I _{DD}	-	-	100	μA	
7	Output Load: CMOS	CL	15			pF	
8	Rise Time	Tr	-		20	ns	
9	Fall Time	Tf	-		20	ns	
10	Output Symmetry	-	40	~	60	%	
11	Start-up Time	Tosc	-	-	10	ms	
12	Aging	-	±3			ppm/yr.	1st. Year at 25°C



2、Mechanical Structure(mm)

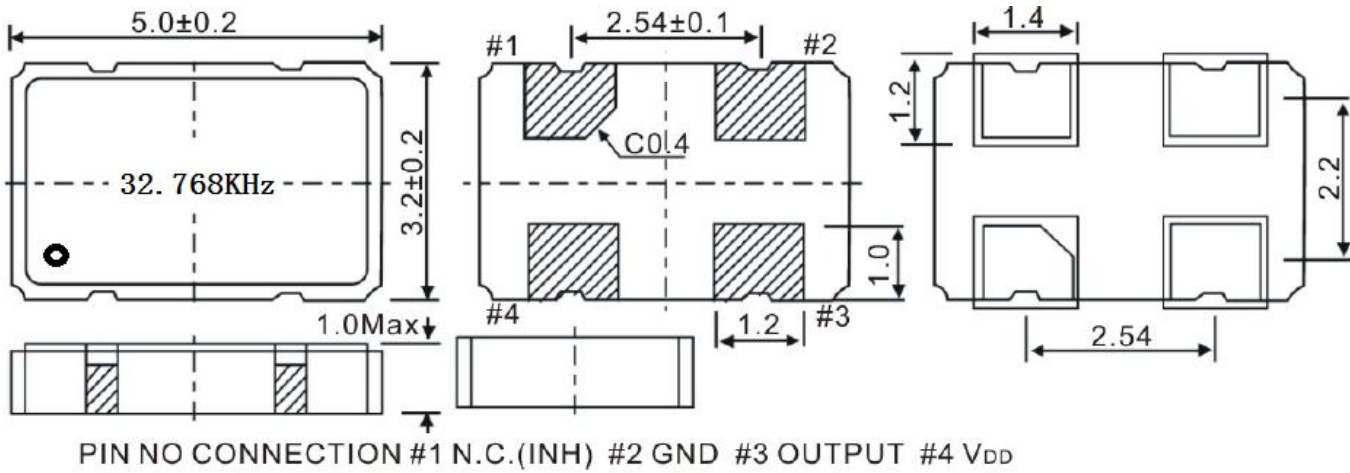

3、Reflow Soldering Curve (RoHS)

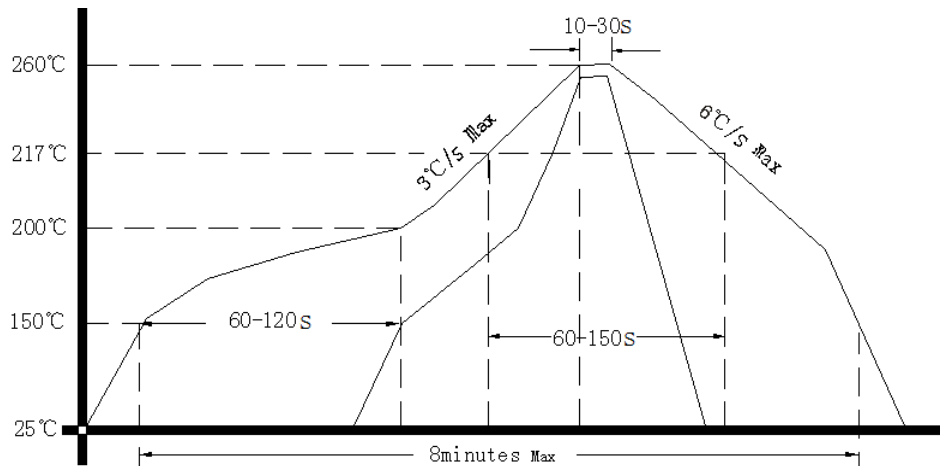

4、Package: Tape & Reel (mm)

