

Travelling Merchant: \_\_\_\_\_

# DATASHEET

Standard:           **O23B-G446-25.60MHz**          

P/N: \_\_\_\_\_

Plot			The Label
Drew	Audited	Approved	Stamp, please! Thanks!
Date: 2021.05.17			

## Guangdong Dapu Telecom Technology Co.,Ltd

Building 5, No.24, Industrial East Road, Songshanhu Park, Dongguan, Guangdong, P.R. China

TEL: 0086-0769-88010888 FAX: 0086-0769-81800098





## 1、Electrical Parameters

MODEL: O23B-G446-25.60MHz						
Item	Description	Parameters			Unit	Test Condition
		Min.	Typ.	Max.		
Output	Frequency	25.60			MHz	
	Output Waveform	Sine wave				
	Level	10		14	dBm	
	Load	50			$\Omega$	
	Harmonics Suppression			-40	dBc	
	Spurious Suppression			-70	dBc	
Frequency Stabilities	Frequency Tolerance vs. Operating Temperature Range	-1		+1	$\times 10^{-9}$	$T_A$ varied from $-20^{\circ}\text{C}$ to $70^{\circ}\text{C}$ , measurement referenced to frequency observed with $T_A = 25^{\circ}\text{C}$ , $V_{cc}=12.0\text{V}$ , $V_c=2.5\text{V}$ , $O_{load}=50\Omega$ , temperature rise speed less than $2^{\circ}\text{C}$ per minute.
	Initial Frequency Tolerance	-0.05		+0.05	$\times 10^{-6}$	Measurement referenced to frequency observed with $T_A=25^{\circ}\text{C}$ , $V_{cc}=12.0\text{V}$ , $V_c=2.5\text{V}$ and after 15 minutes of operation, within 30 days after ex-works.
	Frequency Tolerance vs. Supply Voltage	-0.5		+0.5	$\times 10^{-9}$	measurement referenced to frequency observed $T_A=25^{\circ}\text{C}$ , $V_{cc}$ varied from 11.4V to 12.6V, $V_c = 2.5\text{V}$ , $O_{load}=50\Omega$ ,
	Frequency Tolerance vs. Load	-0.5		+0.5	$\times 10^{-9}$	5% load change measurement referenced to frequency observed with $T_A= 25^{\circ}\text{C}$ , $V_{cc}= 12.0\text{V}$ , $V_c=2.5\text{V}$ and $O_{Load}=50\Omega$ .
	Short-Term Stability: Allan Variance			0.05	$\times 10^{-9}$	Temperature stability, no EMI\EMC or other interference, test after power for 1hour ref. to $25^{\circ}\text{C}$ ; 1s.
	Aging Tolerance Per Day	-0.5		+0.5	$\times 10^{-9}$	$V_{cc}$ , $V_c$ , $T_A$ constant measurement referenced to frequency observed with $T_A=25^{\circ}\text{C}$ , $V_{cc}= 12.0\text{V}$ , $V_c = 2.5\text{V}$ , and after 30 days of operation.
	Aging Tolerance 1 Year	-0.05		+0.05	$\times 10^{-6}$	
Power Supply	Supply Voltage	11.4	12.0	12.6	V	
	Current Consumption			200	mA	@ $25^{\circ}\text{C}$
	Current Consumption during warm up			500	mA	



Voltage Control Characteristics	Frequency Tuning Range	-0.8		-0.4	$\times 10^{-6}$	$V_c=0$ V. measurement referenced to $V_c=2.5V$
		-0.05		+0.05	$\times 10^{-6}$	$V_c=2.5V$ . measurement referenced to exactly 25.60MHz
		+0.4		+0.8	$\times 10^{-6}$	$V_c=5.0V$ . measurement referenced to $V_c=2.5V$
	Linearity			10	%	
	Slope	Positive				
	Input Impedance	100				K $\Omega$
Phase Noise	Phase Noise		-135		dBc/Hz	100Hz
			-145			1KHz
			-150			10KHz
			-150			100KHz
Environmental Conditions	Operable Temperature	-20		+70	$^{\circ}C$	
	Storage Temperature	-40		+85	$^{\circ}C$	
	ESD Level	Human Body Model,class2: 2000V to 4000V; ANSI/ESDA/JEDEC JS-001-2010.				
		Machine Model, class B: 200V to 400V; JEDEC JESD22-A115C.				
	Moisture Sensitivity Level	Not humidity sensitive.				
	Vibration	Test Condition: 0.75mm ;acceleration:10g;10Hz~500Hz, one cycle per 30 min, test 2 hour. (3 times for each 3 directions X ,Y , Z), IEC 68-2-06 Test Fc.				
Shock	50g; 11ms; half sine wave (3 times for each 3 directions X ,Y , Z ),IEC 68-2-27 Test Ea/Severity 50A.					



## 2、 Mechanical Structure(mm)

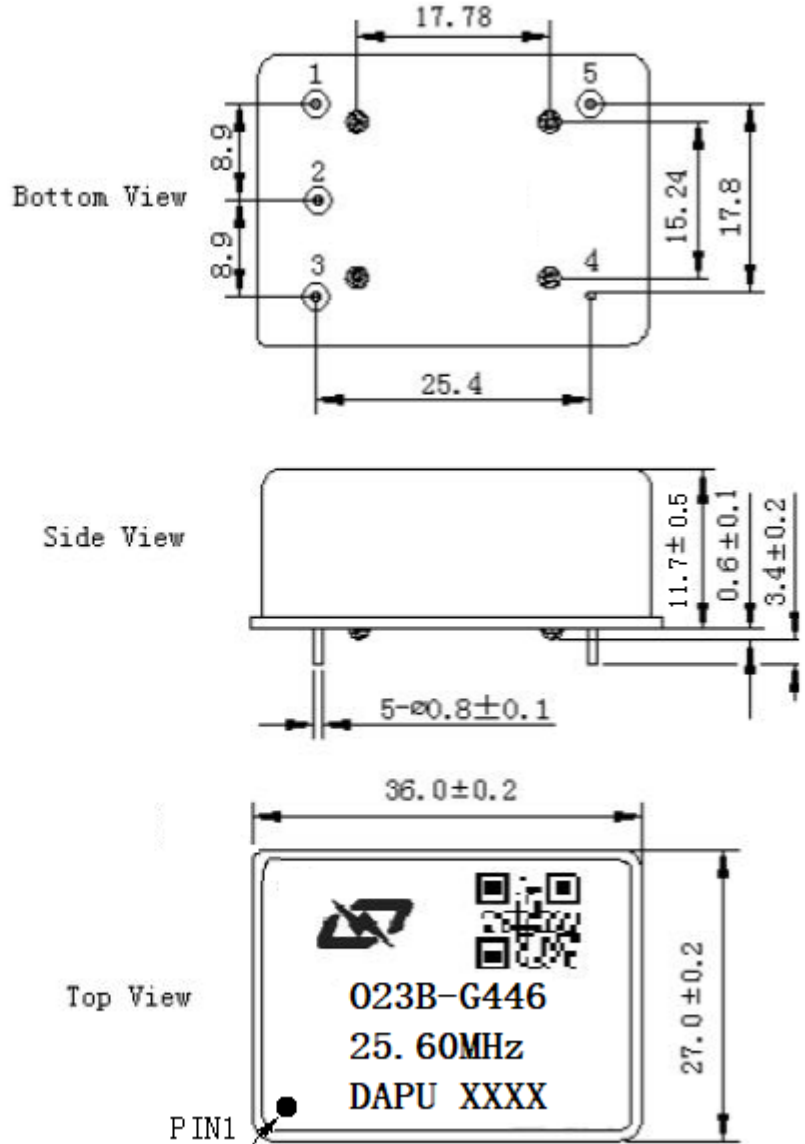

### PIN FUNCTION

PIN	NOTATION	FUNCTION
1	VCC	Supply Voltage
2	NC	Not Connect
3	VC	Control Voltage
4	GND	GND
5	OUTPUT	RF Output

- Note1:** Tolerance ± 0.2mm without mark
- Note2:** Referential weight 20.7g
- Note3:** NC is not connect
- Note4:** The first two xx representative: week  
After two xx representative: year



### 3、 Test Circuit

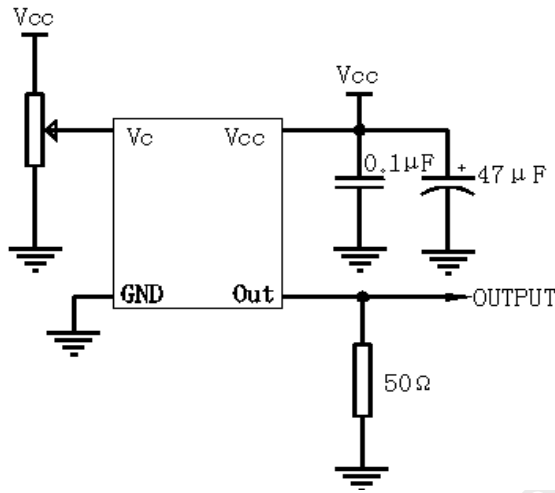

### 4、 Wave Soldering Curve (RoHS)

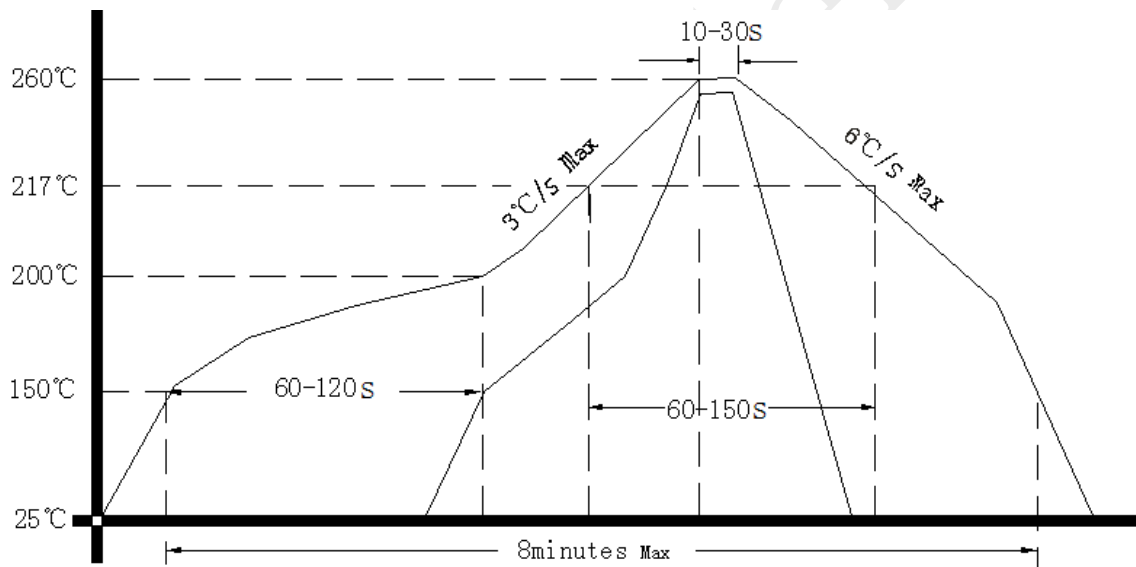

### 5、 Package (mm)

