

Travelling Merchant:

# DATASHEET

Standard: CM55F-N122-10.00MHzP/N: IQCM-200

Plot			The Label
Drew	Audited	Approved	Stamp, please! Thanks!
Date: 2019.06.20			

## GuangdongDapu Telecom TechnologyCo.,Ltd

Bldg13-16,.N.Ind.Zone,SSL Industry Park,GuangDongCity, Guangdong Province, China

TEL: 0086-0769-88010888 FAX: 0086-0769-81800098



### Table of amendment

Version	Revision contents	Prepared by	Revised date
1.0	The first issued	<i>Amway</i>	2019.06.20



## 1、Electrical Parameters

	Parameters	Min.	Typ.	Max.	Unit.	Test Condition	
1 PPSReference Input	Waveform	HCMOS					
	High-Level Output Voltage ( $V_{IH}$ )	2.7			Vdc	50 Ohms	
	Low-Level Output Voltage ( $V_{IL}$ )			0.4	Vdc		
	Pulse Width	10			uSec		
	Connector	Pin 10					
State Input	Parameters	Min.	Typ.	Max.	Unit.		
	Lock Enable	2.7			Vdc	<5mA Load	
	Lock Disable			0.4	Vdc	<5mA Load	
	Connector	Pin 8					
RF Output	Parameters	Min.	Typ.	Max.	Unit.	Test Condition	
	Nominal Frequency		10		MHz		
	Waveform	HCMOS					
	High-level Output voltage ( $V_{OH}$ )	2.7			Vdc	<5mA Load	
	Low-level Output voltage ( $V_{OL}$ )			0.4	Vdc	<5mA Load	
	Rise/Fall Time			8	nSec	<5mA Load	
	Duty Cycle	45	50	55	%	<5mA Load	
	Accuracy	-1		1	E-12	24 hour average when locked to 1 PPS	
	Short-term stability			2	E-11	Temperature stability,no EMI\EMC or other interference,test after power for 1hour ref.to 25 °C ;1s,using PN9000 equipment.	
	Phase noise (All conditions)			-118		dBc/Hz	@ 10Hz offset
				-138		dBc/Hz	@ 100Hz offset
				-148		dBc/Hz	@ 1KHz offset
				-150		dBc/Hz	@ 10KHz offset
			-150		dBc/Hz	@ 100KHz offset	
Connector	Pin 14						
Holdover Capability	Holdover Time	Min.	Typ.	Max.	Unit.		
	24hours	-8.0		+8.0	uSec	$\Delta T = \pm 2^{\circ}C$ , 24 hours holdover after turn on 7days andlock 3days.Temperature variable speed less than 1 °Cper minute	



Supply Voltage	Parameters	Min.	Typ.	Max.	Unit.	
	Supply voltage	4.75	5.0	5.25	Vdc	
	Current consumption			1400	mA	During Warm-up
				600	mA	During steady state operation@25℃
	AC ripple			50	mVpk-pk	10Hz to 1MHz
Connector	Pin 3					
1 PPS Output Waveform Characteristics	Parameters	Min.	Typ.	Max.	Unit.	
	Waveform	HCMOS				
	High-Level Output Voltage(V <sub>OH</sub> )	2.7			Vdc	50 Ohms
	Low-level Output voltage (V <sub>OL</sub> )			0.4	Vdc	
	Pulse width	10			uSec	
	Connector	Pin 12				
State Output	Parameters	Min.	Typ.	Max.	Unit.	
	Lock	2.7			Vdc	<5mA Load
	Holdover			0.4	Vdc	<5mA Load
	Connector	Pin 5				
Environmental Conditions	Parameter	Conditions				
	Operating temperature	-10℃ to +70℃				
	Storage Temperature	-55℃ to +105℃				
	Storagehumidity	30%~80%				
	ESD Level	Human Body Model,class2: 2000V to 4000V; ANSI/ESDA/JEDEC JS-001-2010.				
		Machine Model, class B: 200V to 400V; ANSI/ESDA/JEDEC JS-001-2010.				
	Moisture Sensitivity Level	Not humidity sensitive.				
	Vibration	Test Condition: 0.75mm ;acceleration:10g;10Hz~500Hz, one cycle per 30 min, test 2 hours. (3 times for each 3 directions X , Y , Z), IEC 68-2-06 Test Fc.				
Shock	50g; 11ms; half sine wave (3 times for each 3 directions X , Y , Z ),IEC 68-2-27 Test Ea/Severity 50A.					
Full Package Storage	Relative humidity (%)	20%~70%				
	Temperature (℃)	-10~35℃				



## 2、Mechanical Structure(mm)

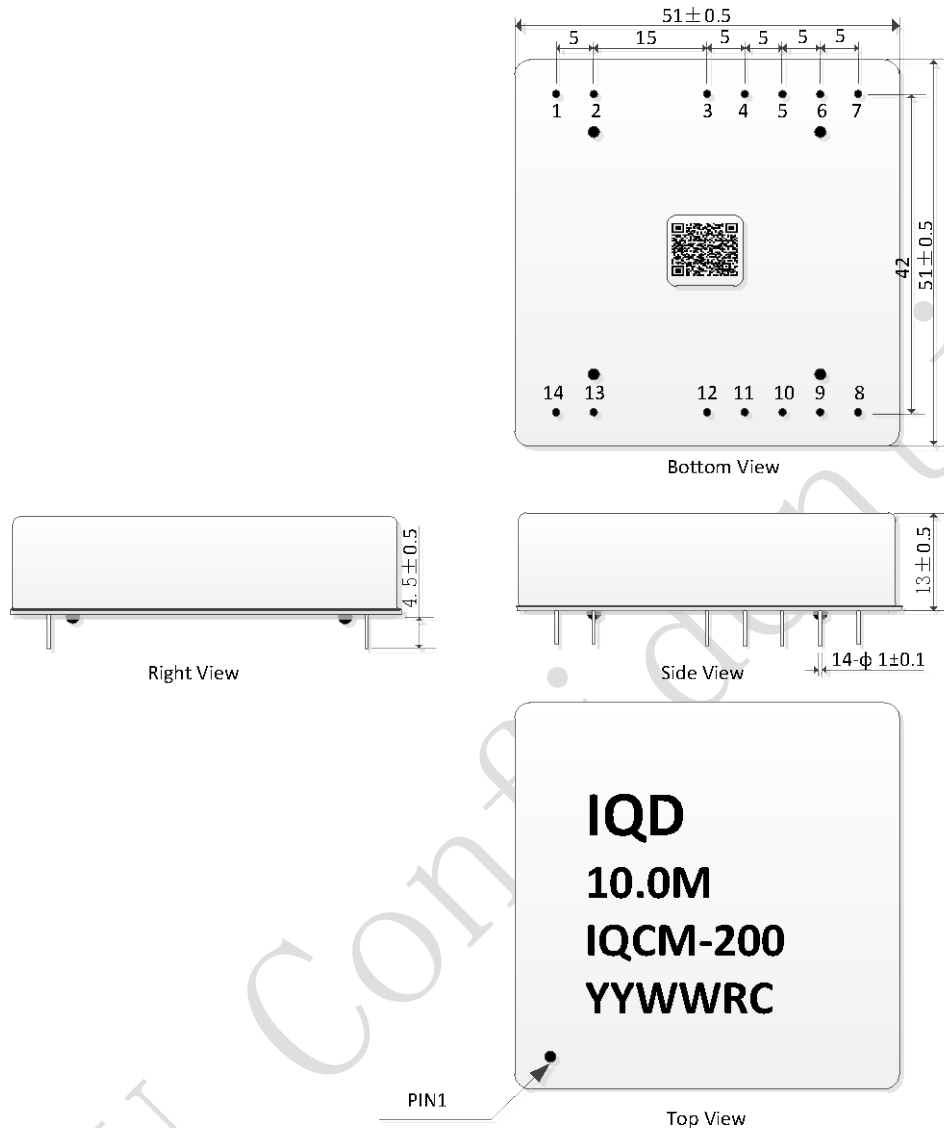

**Note1:** Tolerance  $\pm 0.2$ mm without mark

**Note2:** The first two YY representative: year  
After two WW representative: week

**Note3:** Referential Weight  $52 \pm 5$ g



PIN DEFINITION			
PIN	Name	DESCRIPTION	
3	Vcc +5.0Vdc	Power supply input,4.75V to 5.25V.	
5	Lock OUTPUT	State output.Output high level when the work state is Run2(See section 4),others low level.	
6	RX INPUT	Asynchronous serial data input.9600-N-8-1.	
7	TX OUTPUT	Asynchronous serial data output(See section 5).9600-N-8-1.	
8	State INPUT	H: Lock Enable	The work state is set to normal operationwhen the state input is high.
		L: Lock Disable	The work state is set to hold overwhen the state input is low.
9	NC	Not connected.	
10	1PPS INPUT	1PPS reference input.	
12	1PPS OUTPUT	The clock module 1PPS output.	
14	10MHz OUTPUT	10MHz OCXO frequency output.	
1、 2	NC	Not connected.	
4、 11、 13	GND	GND	

### 3、 Functional Block Diagram

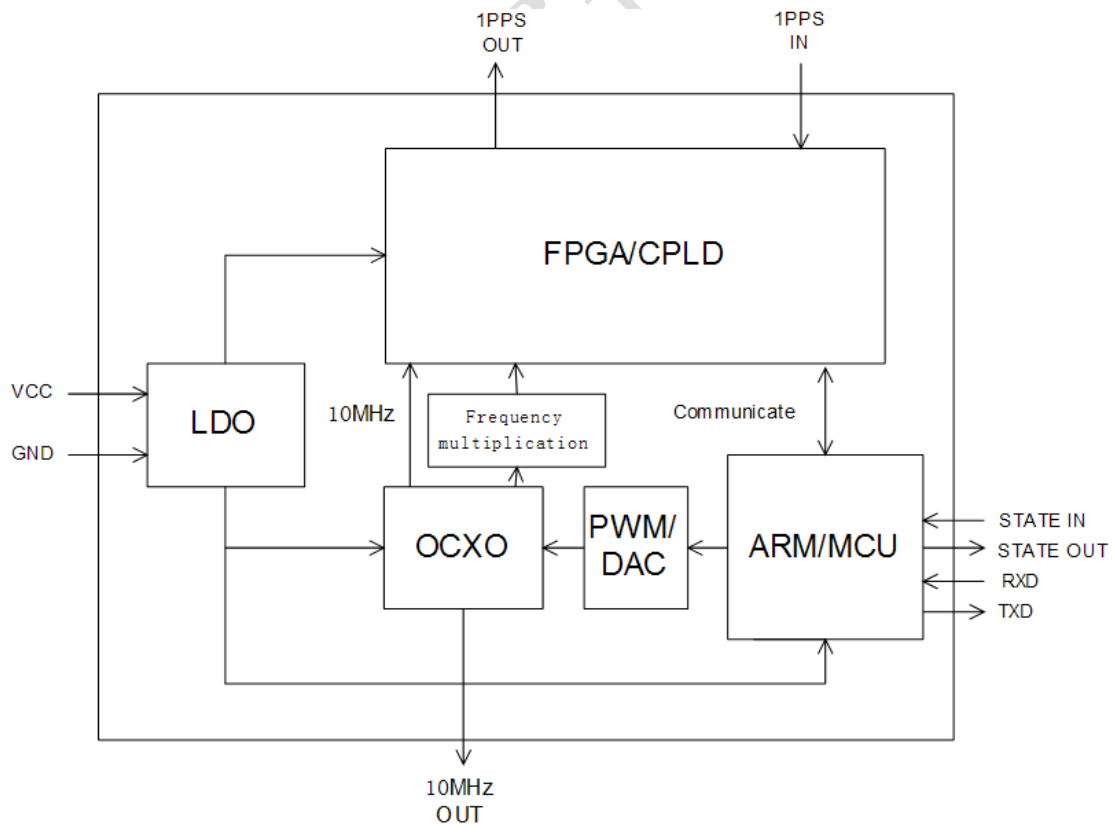



#### 4、 Workflow Diagram

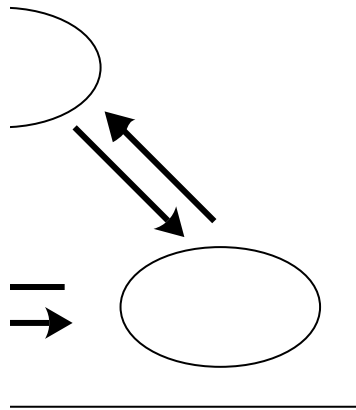

Run1: Fast track. Adjust the OCXO 10MHz output frequency quickly to track the 1PPS of 10MHz with 1PPS reference.

Run2: Slow track. Adjust the OCXO 10MHz output frequency slowly when the phase error is in the define range.

Holdover: GPS 1PPS reference miss, an algorithm has been developed which enables adaptive modeling of the frequency stability of an OCXO with reference to a GPS timing signal.

Free Run: Clock module power on without 1PPS reference anyway.



## 5、 The Product Test Output Message

Example:

\$PDP,00,0,F,Q,-3095,32768.0000,32768.0000,000,000,00000.0000,00000.0000,00000.0000,00000.0000,3-23,+000.0000,-000,www.dptel.com,1.1,2011-05-16\*55

Notes:

In the Format column, c stand for char ,d stand for digit, s stand for sign.

Field No.	Name	Format	Description	Length (byte)
0	\$PDP	\$ccc	Message ID, DAPU Telecom Technology protocol header	4
1	No	dd	Message No.	2
2	TxRxFlag	d	The transmit and receive flag.(0: upper computer transmit; 1: upper computer receive)	1
3	CStatus	c	Current status.(F: 3mins warm-up; L: Lock; H: Holdover)	1
4	TrackStatus	d	Track status (Q: fast track;S: slow track)	1
5	cPHDiff	sdddd	Current phase difference	5
6	cPWM1	dddd.dddd	Current PWM1 (Voltage-controlled value1)	10
7	cPWM2	dddd.dddd	Current PWM2 (Voltage-controlled value2)	10
8	SYNCNT	ddd	The synchronous times	3
9	HCNT	ddd	Hours after enter slow track	3
10	HPAVG	dddd.dddd	The average of the PWM in the last 1 hour	10
11	VCH1	dddd.dddd	Voltage-controlled compensation value every 1 hour	10
12	HPMOD	dddd.dddd	The Module PWM Value	
13	VCM10	dddd.dddd	Voltage-controlled compensation value every 10 minutes	10
14	POS	d-dd	The position of the product.(Layer-No), just for the inner test.	4
15	inT	sddd.dddd	NA	9
16	TcPHDiff	sdddd	The product current phase difference	5
17	Website		www.dptel.com	13
18	Version	d.d	version	3
19	Date	dddd-dd-dd	Date	10
20		dd	55	2
21	END		<CR><LF>	2





## 6、 Application Information

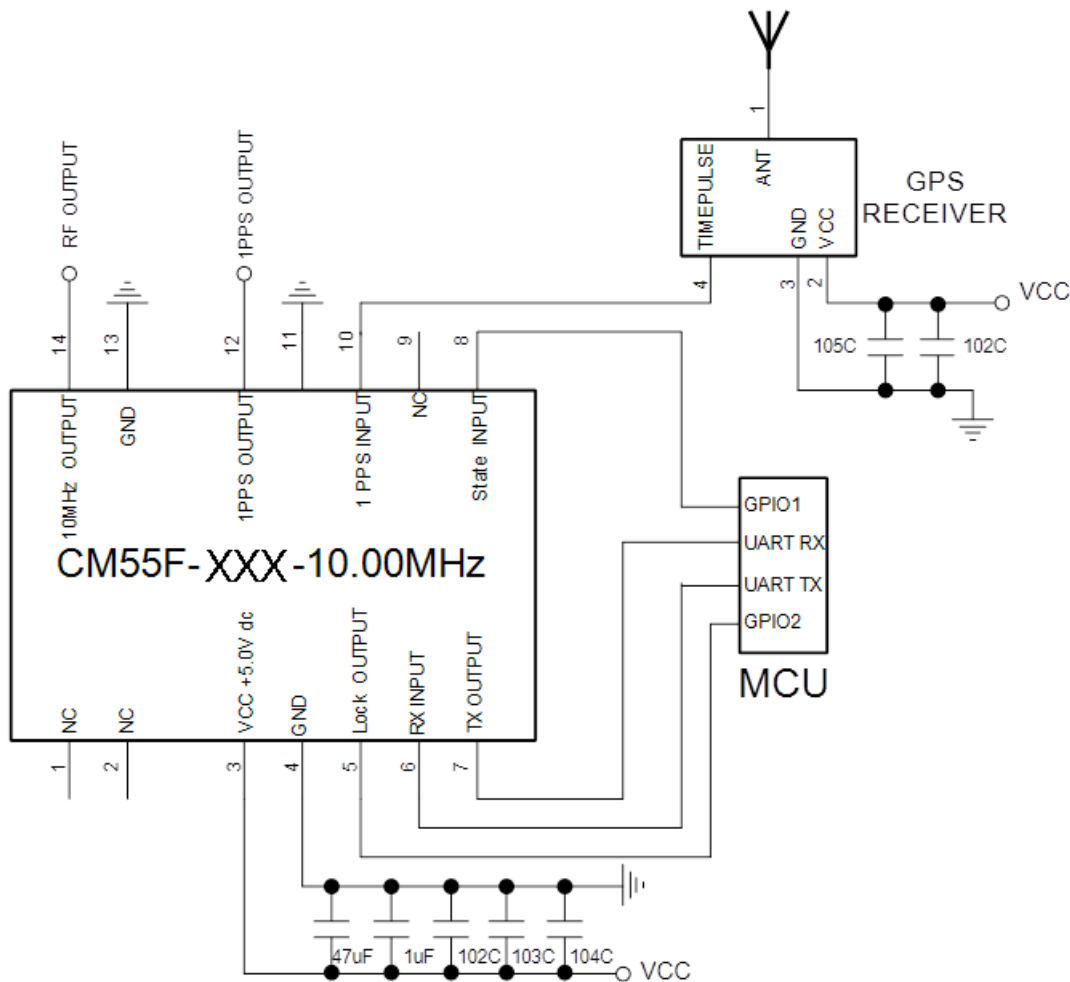

GPS RECEIVER supplies 1PPS signal to the clock module CM55F.

The MCU monitors the work state of CM55F.

The CM55F is operated with a supply of 5V.

**Note1:**Power on more than seven days is necessary for the OCXO drift fast in the first four days.

**Note2:**The adaptive model can be built with at least two days good GPS signal. Every time power off will lose the model.

**Note3:**The work state is set to hold over when the state input is low, no matter the GPS 1PPS effective or not.



## 7、Coding Rules

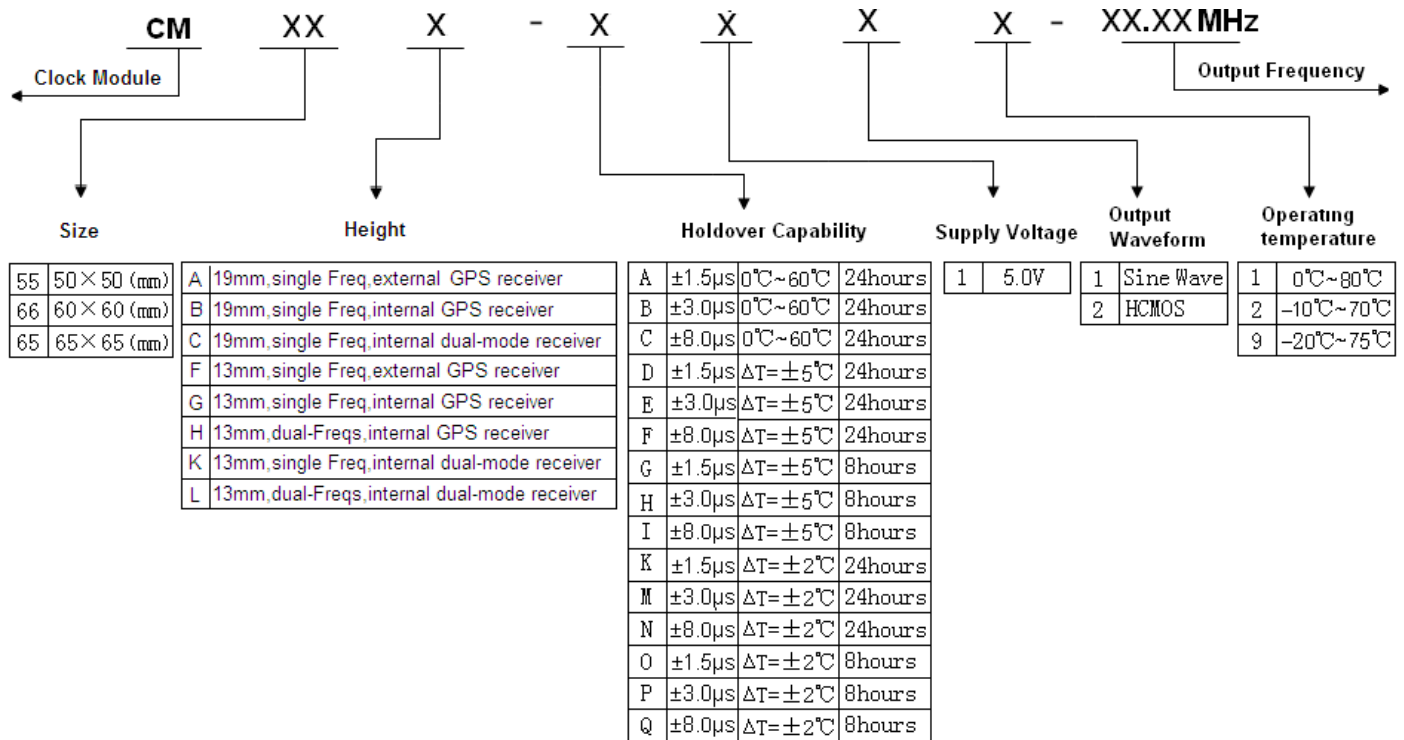

## 8、 WaveSoldering Curve(RoHS)

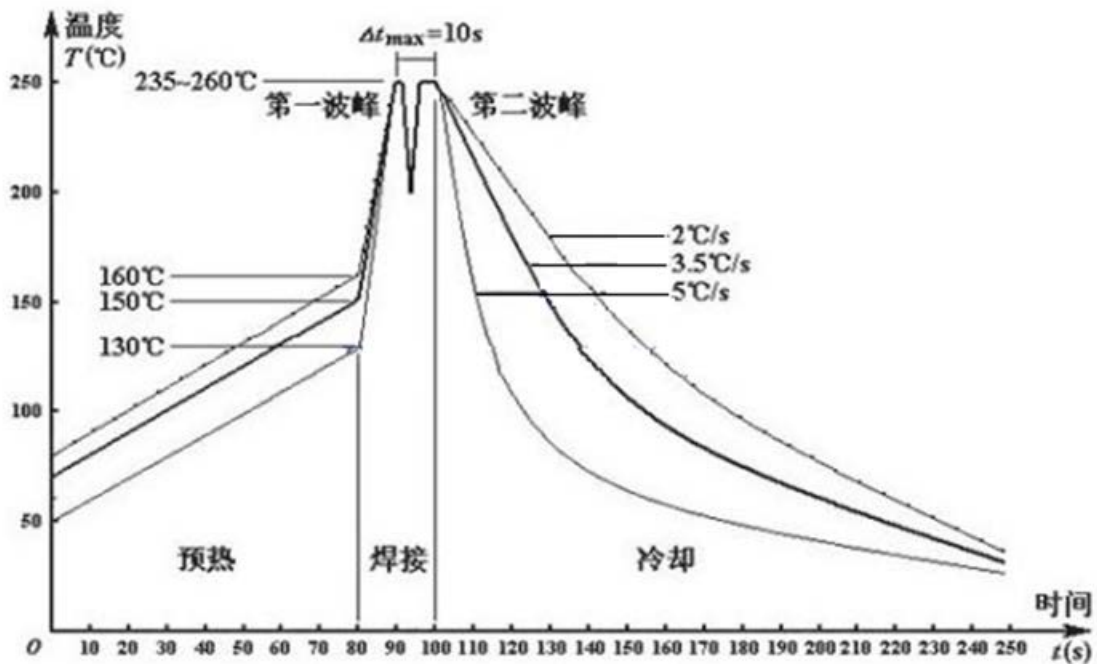



## 9、Package (mm)

