

Travelling Merchant: _____

DATASHEET

Standard: DP9A73728001

Plot			The Label
Drew	Audited	Approved	Stamp, please! Thanks!
Date: 2019.06.05			

Guangdong Dapu Telecom Technology Co.,Ltd

Bldg13-16,.N.Ind.Zone,SSL Industry Park, Dongguan City, Guangdong Province, China

TEL: 0086-0769-88010888 FAX: 0086-0769-81800098



1. Electrical Parameters

MODEL: DP9A73728001							
No.	Parameters	SYM.	Electrical Spec.				Notes
			Min.	Typ.	Max.	Units	
1	Nominal Frequency	FL	7.3728			MHz	
2	Oscillation Mode	-	Fundamental			-	
3	Load Capacitance	CL		20		pF	
4	Frequency Tolerance	-	-20		+20	ppm	Refer to Center Frequency @ 25°C ± 3°C
5	Stability Over Temperature	-	-30		+30	ppm	Refer to Operating Temp. @ -40~85°C
6	Operating Temperature Range	-	-20	~	+70	°C	
7	Aging	-	-3		+3	ppm	1st Year
8	Drive Level	DL	0.1		100	uW	
9	Effective Series Resistance	ESR	-	-	80	Ω	
10	Shunt Capacitance C0	C0		-	7	pF	
11	Insulation Resistance	IR	500	-	-	MΩ	at DC 100V
12	Storage Temperature Range	-	-40	~	+85	°C	
13	Vibration	Test Condition: 0.75mm ;acceleration:10g;10Hz~500Hz, one cycle per 30 min, test 2 hour. (3 times for each 3 directions X , Y , Z), IEC 68-2-06 Test Fc.					
14	Shock	50g; 11ms; half sine wave (3 times for each 3 directions X , Y , Z),IEC 68-2-27 Test Ea/Severity 50A.					



2. Mechanical Structure (mm)

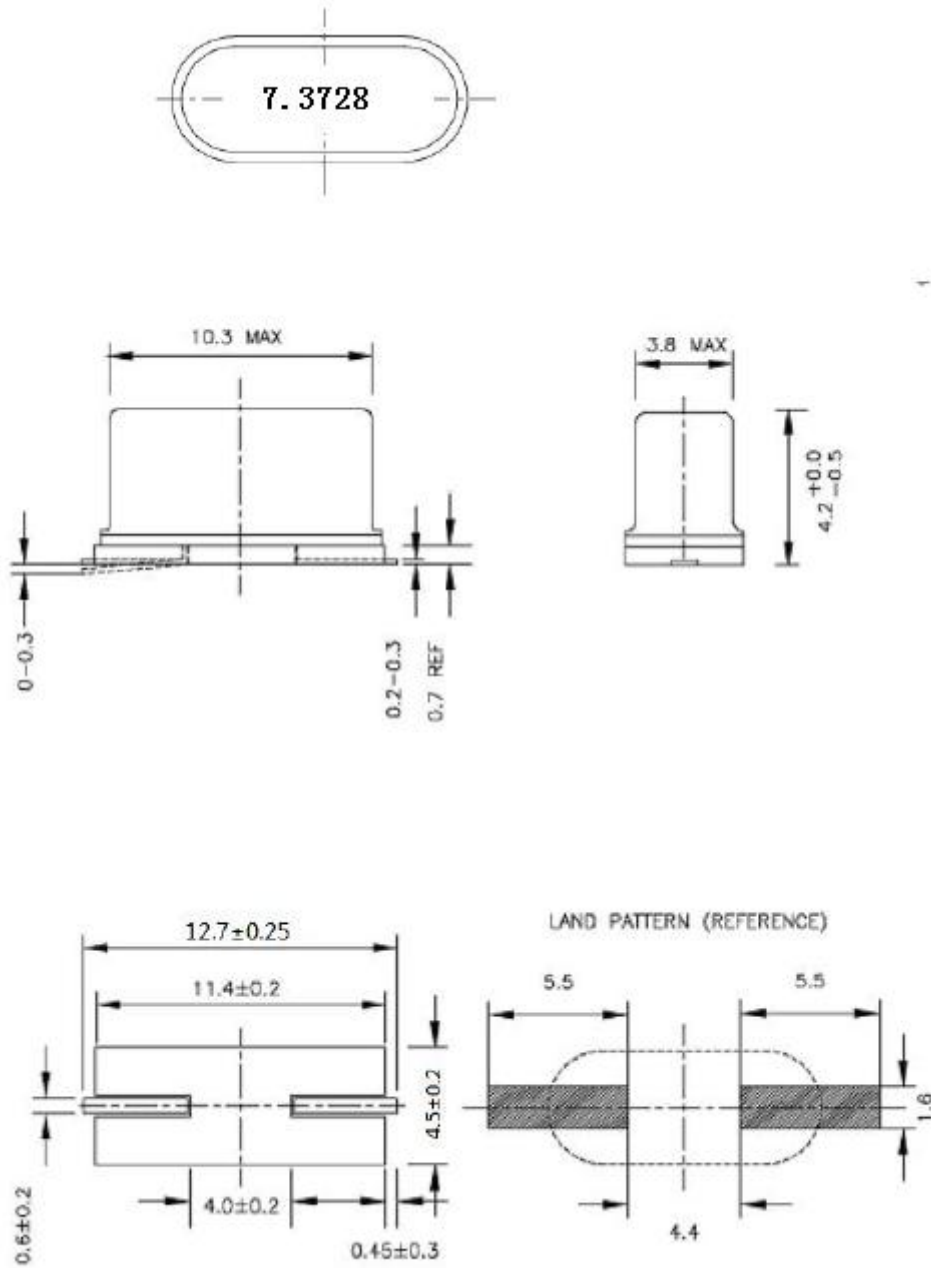



4、 Wave Soldering Curve (RoHS)

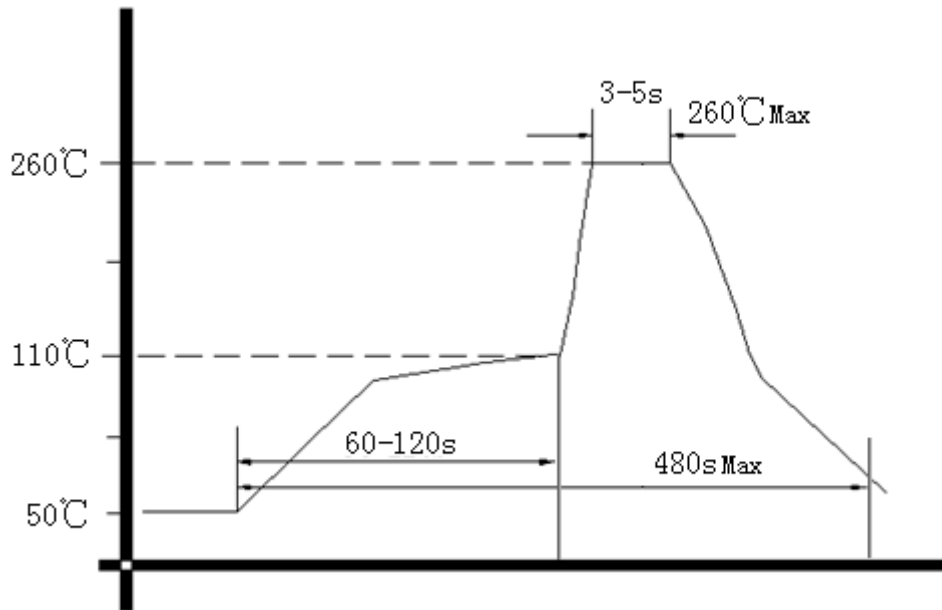

4. Package

