

Travelling Merchant: \_\_\_\_\_

# DATASHEET

Standard: DP7X33333303

Plot			The Label
Drew	Audited	Approved	Stamp, please! Thanks!
Date: 2019.05.20			

**Guangdong Dapu Telecom Technology Co.,Ltd**

Bldg13,.N.Ind.Zone,SSL Industry Park, Dongguan City, Guangdong Province, China

TEL: 0086-0769-88010888 FAX: 0086-0769-81800098



## 1、Electrical Parameters

MODEL: DP7X33333303							
No.	Parameters	SYM.	Electrical Spec.				Notes
			Min.	Typ.	Max.	Units	
1	Nominal Frequency	FL	33.3333			MHz	
2	Output waveform		CMOS				
3	Frequency Stability		-20		+20	ppm	At25 ± 2°C
			-20		+20	ppm	-40-85°C
4	Operating Temperature	Topr	-40		+85	°C	
5	Storage Temperature Range		-55		+125	°C	
6	Output Load	CL			15.0	pF	
7	Supply Voltage		1.65		3.65	V	
8	Symmetry of Wave From		45	50	55	%	
9	Current				5.0	mA	At maximum supply voltage
10	Output Voltage High	VOH	90%Vdd			V	
11	Output Voltage Low	VOL			10%Vdd	V	
12	Rise Time	Tr			5.0	ns	
13	Fall Time	Tf			5.0	ns	
14	Tri-State Output Active		0.7Vdd			V	Pin 1 Tri-state
15	Tri-State Output in High-Impedance state				0.3Vdd	V	
16	Start-up Time	Tosc			5	ms	
17	Aging		-3		+3	ppm	Frequency drift in first year



## 2、 Mechanical Structure(mm)

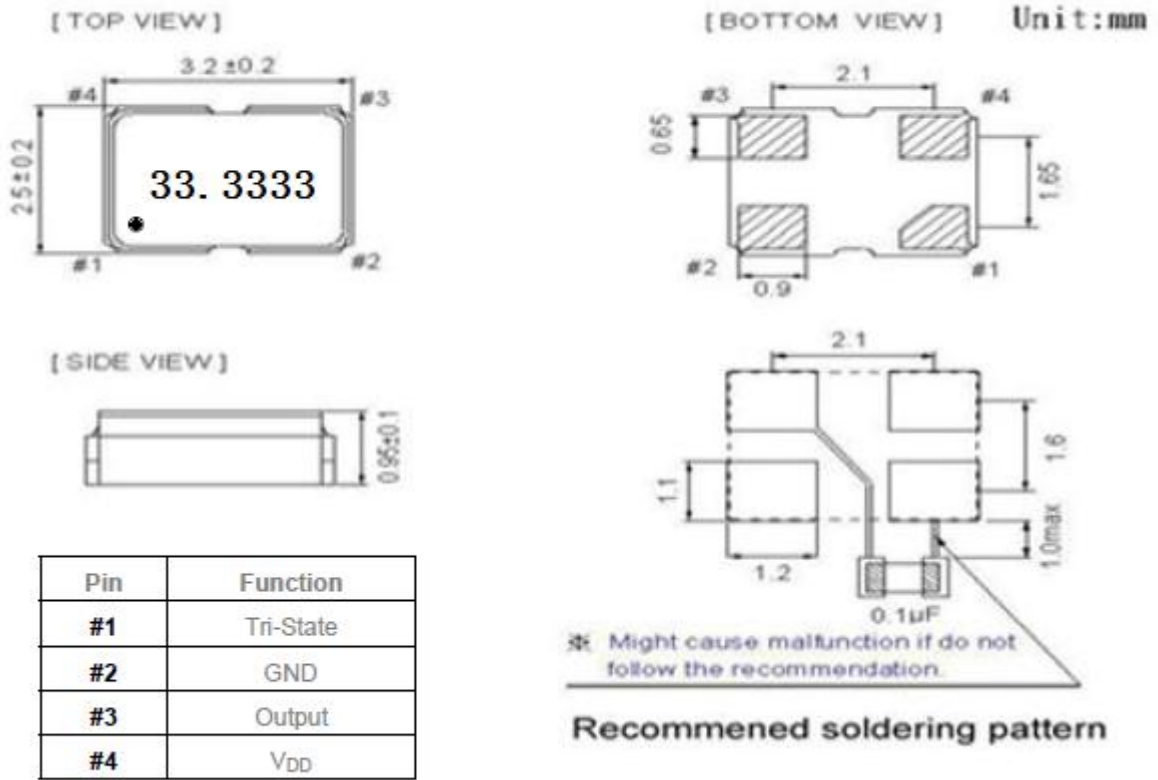

## 3、 Test Circuit (CMOS Load)

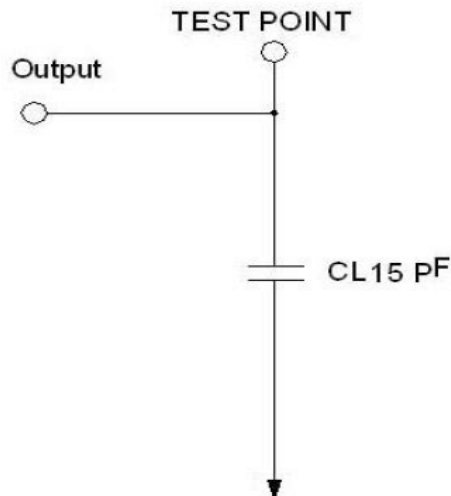



#### 4、 Output Waveform(CMOS Load)

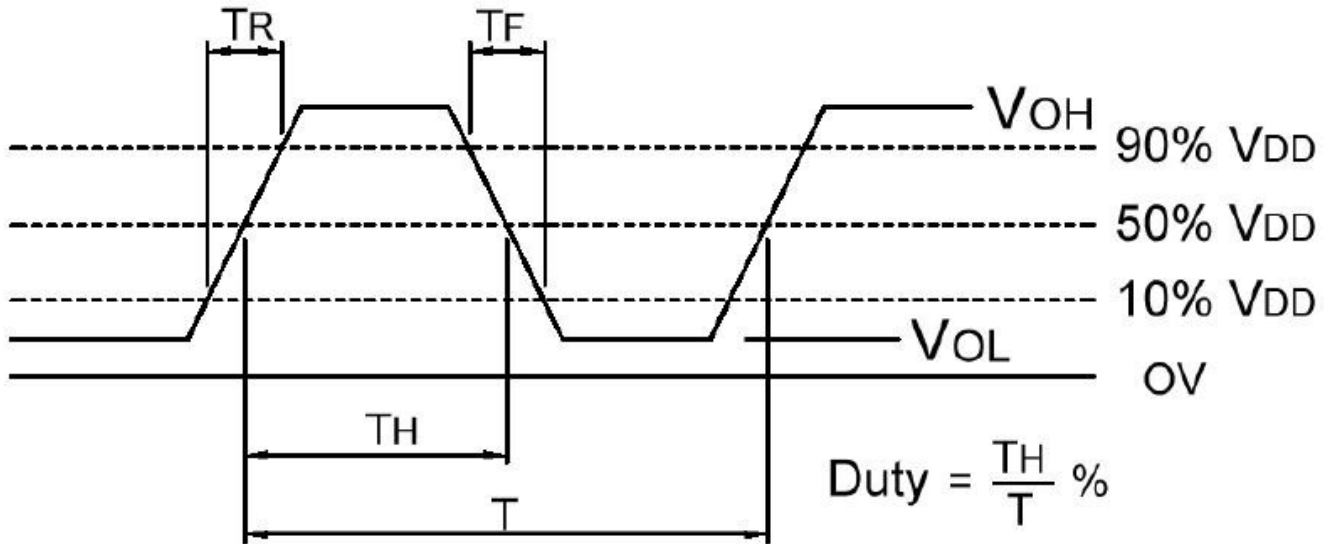

#### 5、 Recommended Ir Reflow Profile

##### ➤ IR REFLOW PROFILE OF CERAMIC SMD PRODUCTS FOR Pb FREE PROCESS

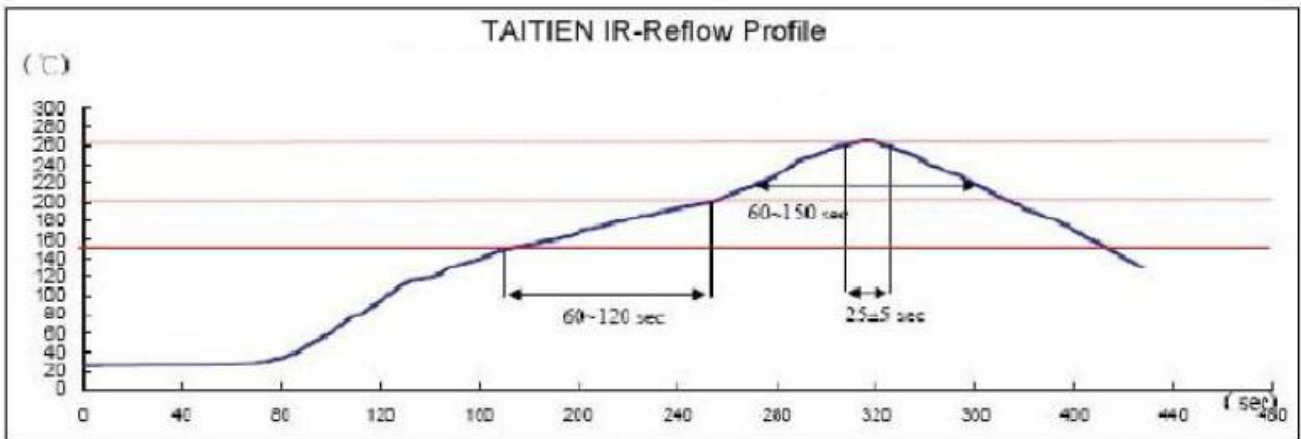

IR-Reflow Test

Reference Standard : JEDEC-STD 020

Test Conditions: Pre-heating : 150°C to 200 °C , 60~120 sec

Heating : 217 °C , 60~150 sec

Peak Temperature : 260±5 °C , 25±5 sec



## 6、 Package: Tape & Reel (mm)

### > TAPE (CARRIER) DIMENSIONS

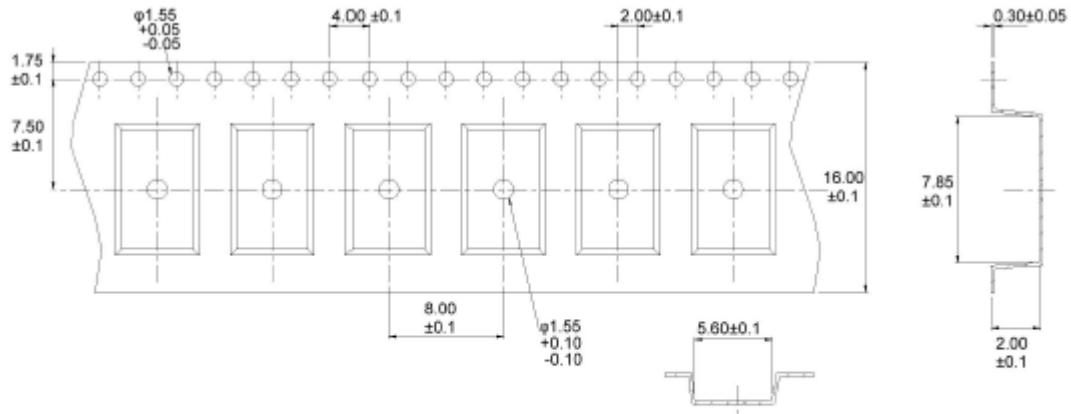

### > THE DIRECTION OF PACKING

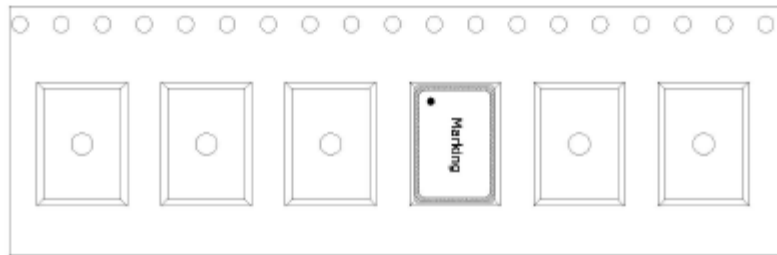

### > REEL DIMENSIONS

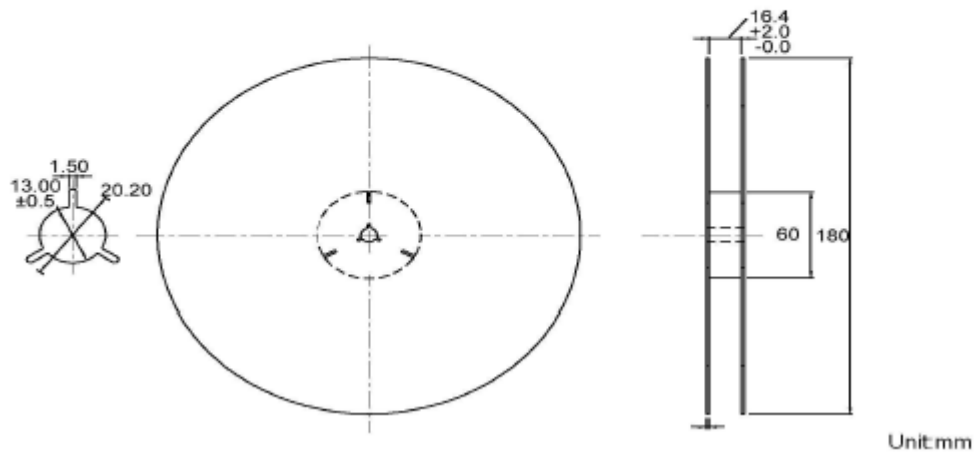

Unit:mm