

Travelling Merchant: _____

DATASHEET

Standard: **T22B-P329-4.896MHz**

P/N: _____

Plot			The Label
Drew	Audited	Approved	Stamp, please! Thanks!
Date: 2017.12.27			

Guangdong Dapu Telecom Technology Co.,Ltd

Bldg13-16,.N.Ind.Zone,SSL Industry Park, Dongguan City, Guangdong Province, China

TEL: 0086-0769-88010888 FAX: 0086-0769-81800098



1. Electrical Parameters

MODEL: T22B-P329-4.896MHz						
Item	Description	Parameters			Unit	Test Condition
		Min.	Typ.	Max.		
Output	Frequency	4.896			MHz	
	Output Waveform	HCMOS				
	Output Low Voltage			0.4	V	$V_{cc}=5.0V, O_{load}=15pF$
	Output High Voltage	4.0			V	$V_{cc}=5.0V, O_{load}=15pF$
	Duty Cycle	45	50	55	%	@50%
	Rise / Fall Time (10%~90%)			6	ns	
	Load	15			pF	
Frequency Stabilities	Frequency Tolerance vs. Operating Temperature Range	-1.0		+1.0	$\times 10^{-6}$	T_A varied from -10°C to 70°C, measurement referenced to frequency observed with $T_A=25^\circ C, V_{cc}=5.0V, O_{load}=15pF$, temperature variable speed less than 2°C per minute.
	Initial Frequency Tolerance	-1.0		+1.0	$\times 10^{-6}$	Measurement referenced to frequency observed with $T_A=25^\circ C, V_{cc}=5.0V$, and after 15 minutes of operation, within 30 days after ex-works.
	Frequency Tolerance vs. Supply Voltage	-0.2		+0.2	$\times 10^{-6}$	measurement referenced to frequency observed $T_A=25^\circ C, V_{cc}$ varied from 4.75V to 5.25V, and $O_{Load}=15pF$.
	Frequency Tolerance vs. Load	-0.2		+0.2	$\times 10^{-6}$	5% load change measurement referenced to frequency observed with $T_A=25^\circ C, V_{cc}=5.0V$, and $O_{Load}=15pF$.
	Aging Tolerance Per Day	-0.02		+0.02	$\times 10^{-6}$	V_{cc}, V_c, T_A constant measurement referenced to frequency observed with $T_A=25^\circ C,$
	Aging Tolerance 1 Year	-1.0		+1	$\times 10^{-6}$	$V_{cc}=5.0V$, and after 30 days of operation.
Power Supply	Current Consumption			15	mA	@25°C, $V_{cc}=5.0V, O_{Load}=15pF$.
	Supply Voltage	4.75	5.0	5.25	V	



Phase Noise	Phase Noise		-125	-120	dBc/Hz	1KHz
Environmental Conditions	Operable Temperature	-10		+70	°C	
	Storage Temperature	-45		+105	°C	
	ESD Level	Human Body Model,class2: 2000V to 4000V; ANSI/ESDA/JEDEC JS-001-2010.				
		Machine Model, class B: 200V to 400V; ANSI/ESDA/JEDEC JS-001-2010.				
	Moisture Sensitivity Level	Level 2.				
	Vibration	Test Condition: 0.75mm ;acceleration:10g;10Hz~2000Hz, one cycle per 30 min, test 2 hour. (3 times for each 3 directions X , Y , Z) .IEC 68-2-06 Test Fc.				
Shock	100g; 6ms; half sine wave (3 times for each 3 directions X , Y , Z),IEC 68-2-27 Test Ea/Severity 50A.					
Full Package Storage	Relative humidity (%)	20%~70%				
	Temperature (°C)	-10~35°C				



2. Mechanical Structure (mm)

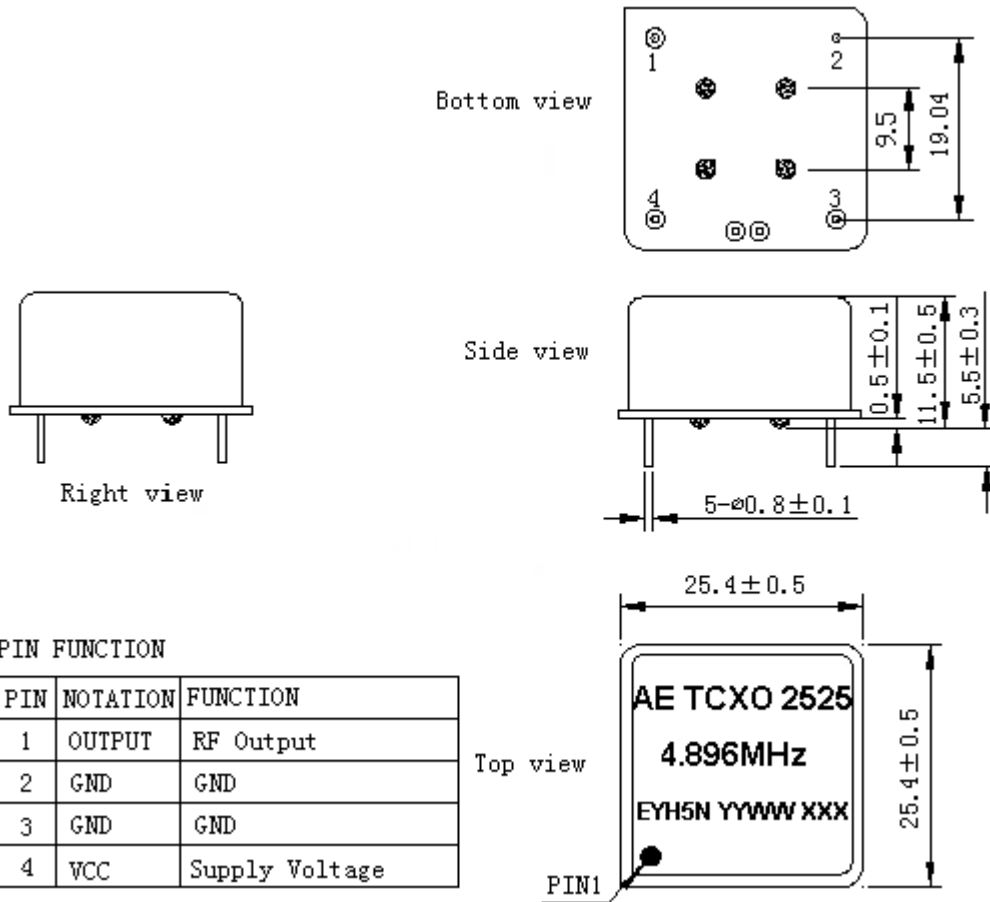

- Note1:** Tolerance $\pm 0.2\text{mm}$ without mark
- Note2:** Referential weight 13.6g
- Note3:** The two yy representative: year
After two ww representative: week
At last xxx representative: serial number



3. Test Circuit

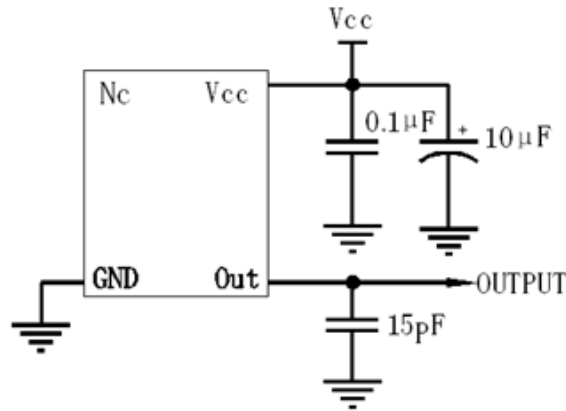

4. Reflow Soldering Curve (RoHS)

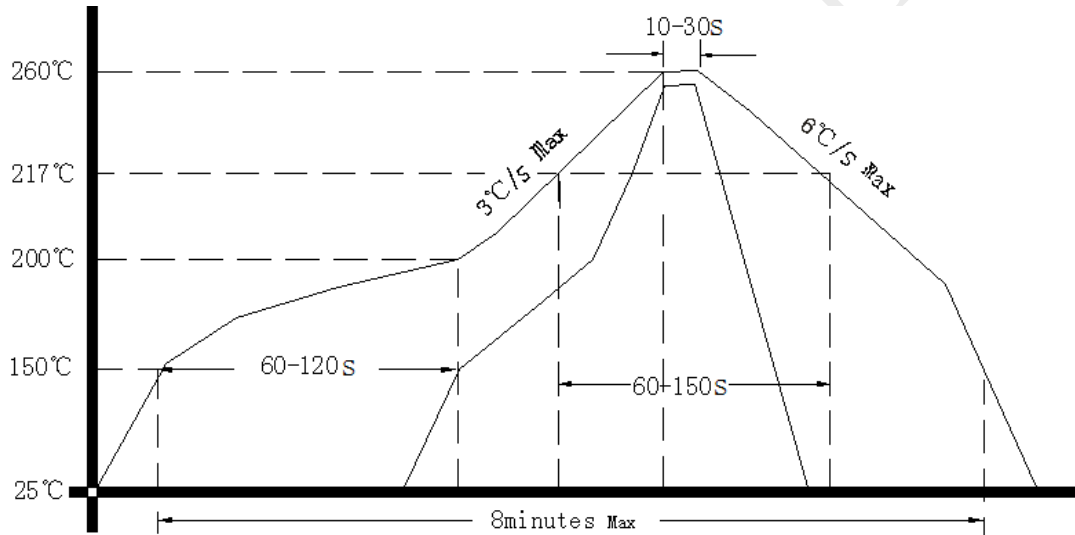

5. Package (mm)

