

Travelling Merchant: \_\_\_\_\_

# DATASHEET

Standard:           **O55A-K325-10.00MHz**          

P/N: \_\_\_\_\_

Plot			The Label
Drew	Audited	Approved	Stamp, please! Thanks!
<i>Amway.wei</i>	<i>Tommy Wang</i>	<i>James Liu</i>	
Date: 2017.12.19			

## Guangdong Dapu Telecom Technology Co.,Ltd

Bldg13-16,.N.Ind.Zone,SSL Industry Park, Dongguan City, Guangdong Province, China

TEL: 0086-0769-88010888 FAX: 0086-0769-81800098





## 1. Electrical Parameters

MODEL: O55A-K325-10.00MHz						
Item	Description	Parameters			Unit	Test Condition
		Min.	Typ.	Max.		
Output	Frequency	10.00			MHz	
	Output Waveform	HCMOS				
	Output Low Voltage			0.4	V	$V_{cc}=5.0V, O_{load}=15pF$
	Output High Voltage	2.4			V	$V_{cc}=5.0V, O_{load}=15pF$
	Duty Cycle	45	50	55	%	@50%
	Rise / Fall Time (10%~90%)			10	ns	
	Load	15			pF	
Frequency Stabilities	Frequency Tolerance vs. Operating Temperature Range	-0.02		+0.02	$\times 10^{-9}$	$T_A$ varied from $-40^{\circ}C$ to $85^{\circ}C$ , measurement referenced to frequency observed with $f_{ref}=(f_{max}+f_{min})/2, V_{cc}=5.0V, O_{load}=15pF$ , temperature variable speed less than $2^{\circ}C$ per minute.
	Initial Frequency Tolerance	-0.05		+0.05	$\times 10^{-6}$	Measurement referenced to frequency observed with $T_A=25^{\circ}C, V_{cc}=5.0V, DAC=0x7FFF$ , and after 15 minutes of operation, within 30 days after ex-works.
	Frequency Tolerance vs. Supply Voltage	-0.02		+0.02	$\times 10^{-9}$	measurement referenced to frequency observed $T_A=25^{\circ}C, V_{cc}$ varied from 4.75V to 5.25V, $O_{load}=15pF$ .
	Frequency Tolerance vs. Load	-0.02		+0.02	$\times 10^{-9}$	5% load change measurement referenced to frequency observed with $T_A=25^{\circ}C, V_{cc}=5.0V$ , and $O_{Load}=15pF$ .
	Short-Term Stability: Allan Variance			0.005	$\times 10^{-9}$	Temperature stability, no EMI/EMC or other interference, test after power for 1 hour ref. to $25^{\circ}C$ ; 1s, using PN9000 equipment.
	G-sensitivity			1.5	$\times 10^{-9}/G$	X,Y,Z Total
	Aging Tolerance Per Day	-0.1		+0.1	$\times 10^{-9}$	$V_{cc}, T_A$ constant measurement referenced to frequency observed with $T_A=25^{\circ}C, V_{cc}=5.0V$ , and after 7 days of operation.
	Aging Tolerance 1 Year	-0.01		+0.01	$\times 10^{-6}$	$V_{cc}, T_A$ constant measurement referenced to frequency observed with $T_A=25^{\circ}C, V_{cc}=5.0V$ , and after 30 days of operation.
Power Supply	Supply Voltage	4.75	5.0	5.25	V	
	Steady Consumption			900	mA	@ $25^{\circ}C$
	Warm up current			2600	mA	
	Warm-up time			15	min	@ $25^{\circ}C$ within $\pm 0.015 \times 10^{-6}$ of final frequency with reference after 1 hour on.



DAC Control Characteristics	Frequency Tuning Range	-0.5		-0.2	$\times 10^{-6}$	DAC=0x0000. measurement referenced to DAC=0x7FFF
		-0.05		+0.05	$\times 10^{-6}$	DAC=0x7FFF. measurement referenced to Exactly 10.00MHz
		+0.2		+0.5	$\times 10^{-6}$	DAC=0xFFFF. measurement referenced to DAC=0x7FFF
	Linearity			10	%	
	Slope	Positive				
	Input Impedance	100				K $\Omega$
Phase Noise	Phase Noise		-100	-90	dBc/Hz	1Hz
			-130	-120		10Hz
			-145	-135		100Hz
			-150	-145		1KHz
			-155	-150		10KHz
			-155	-150		100KHz
			-155	-150		1MHz
Environmental Conditions	Operable Temperature	-40		+85	$^{\circ}\text{C}$	
	Storage Temperature	-55		+105	$^{\circ}\text{C}$	
	ESD Level	Human Body Model, class2: 2000V to 4000V; ANSI/ESDA/JEDEC JS-001-2010.				
		Machine Model, class B: 200V to 400V; ANSI/ESDA/JEDEC JS-001-2010.				
	Moisture Sensitivity Level	Level 2.				
	Vibration	Test Condition: 0.75mm ;acceleration:10g;10Hz~500Hz, one cycle per 30 min, test 2 hour. (3 times for each 3 directions X ,Y , Z), IEC 68-2-06 Test Fc.				
Shock	50g; 11ms; half sine wave (3 times for each 3 directions X, Y, Z),IEC 68-2-27 Test Ea/Severity 50A.					
Full Package Storage	Relative humidity (%)	20%~70%				
	Temperature ( $^{\circ}\text{C}$ )	-10~35 $^{\circ}\text{C}$				



## 2. Mechanical Structure(mm)

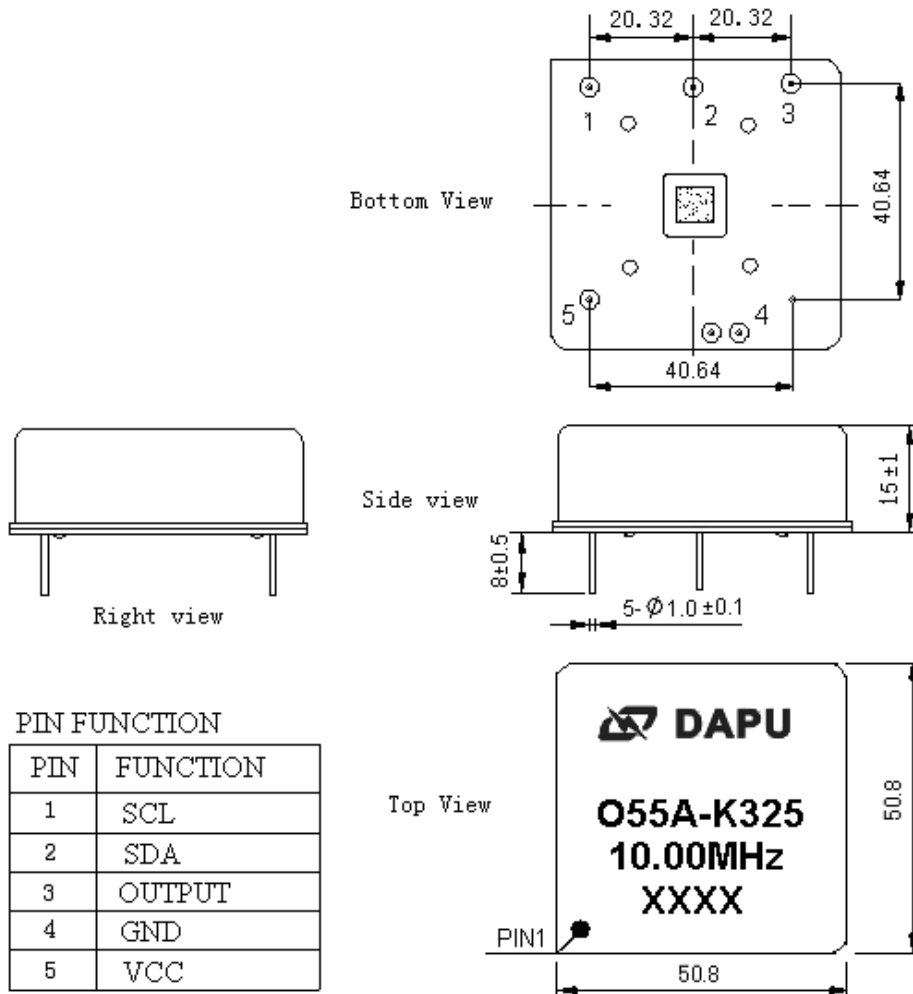

**Note1:** Tolerance  $\pm 0.2$ mm without mark

**Note2:** The first two xx representative: week  
After two xx representative: year

**Note3:** Referential weight 56.1g

## 3. I2C Devices Address

### 3.1 DIGITAL-TO-ANALOG CONVERTER,VOLTAGE OUTPUT

Device name : DAC8571

Device supplier : TI

Device address : 1001100

### 3.2. DIGITAL THERMOMETER AND THERMOSTAT

Device name: LM75

Device supplier: National

Device address: 1001000

Note: More detailed information see the datasheet provide by the supplier.



#### 4. Test Circuit

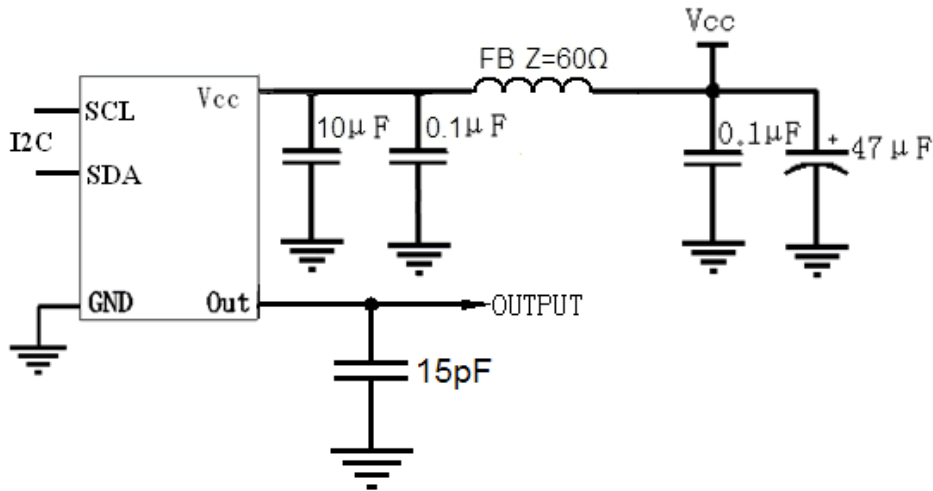

#### 5. Reflow Soldering Curve (RoHS)

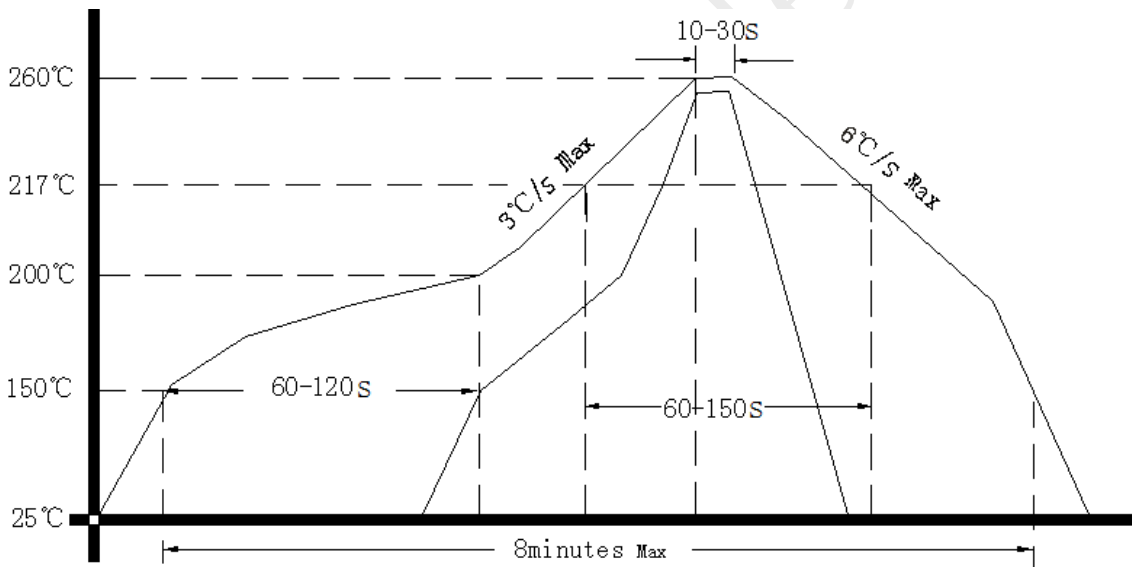

#### 5. Package (mm)

