

Travelling Merchant: \_\_\_\_\_

# DATASHEET

Standard: T11A-H329-102.40MHz-A

P/N: \_\_\_\_\_

Plot			The Label
Drew	Audited	Approved	Stamp, please! Thanks!
Date: 2018.11.20			

## Guangdong Dapu Telecom Technology Co.,Ltd

Bldg13-16,.N.Ind.Zone,SSL Industry Park, Dongguan City, Guangdong Province, China

TEL: 0086-0769-88010888 FAX: 0086-0769-81800098





## 1. Electrical Parameters

MODEL: T11A-H329-102.40MHZ-A						
Item	Description	Parameters			Unit	Test Condition
		Min.	Typ.	Max.		
Output	Frequency	102.40			MHz	
	Output Waveform	HCMOS				
	Output Low Voltage			0.4	V	$V_{cc}=5.0V, O_{load}=15\text{ pF}$
	Output High Voltage	2.7			V	$V_{cc}=5.0V, O_{load}=15\text{ pF}$
	Duty Cycle	45	50	55	%	@50%
	Rise / Fall Time (10%~90%)			5	ns	@25°C
	Load	15			pF	
Frequency Stabilities	Frequency Tolerance vs. Operating Temperature Range	-2		+2	$\times 10^{-6}$	$T_A$ varied from -40°C to 85°C, measurement referenced to frequency observed with $T_A = 25^\circ\text{C}$ , $V_{cc} = 5.0V$ , $O_{load} = 15\text{ pF}$ , temperature variable speed less than 2°C per minute.
	Initial Frequency Tolerance	-1		+1	$\times 10^{-6}$	Measurement referenced to frequency observed with $T_A = 25^\circ\text{C}$ , $V_{cc} = 5.0V$ within 30 days after ex-works.
	Frequency Tolerance vs. Supply Voltage	-0.1		+0.1	$\times 10^{-6}$	measurement referenced to frequency observed $T_A = 25^\circ\text{C}$ , $V_{cc}$ varied from 4.75V to 5.25V, and $O_{Load} = 15\text{ pF}$ .
	Frequency Tolerance vs. Load	-0.1		+0.1	$\times 10^{-6}$	5% load change measurement referenced to frequency observed with $T_A = 25^\circ\text{C}$ , $V_{cc} = 5.0V$ , $O_{Load} = 15\text{ pF}$ .
	Aging Tolerance Per Day	-0.02		+0.02	$\times 10^{-6}$	$T_A = 25^\circ\text{C}$ , $V_{cc} = 5.0V$ , and after 1h of operation.
	Aging Tolerance 1 Year	-1		+1	$\times 10^{-6}$	
Power Supply	Current Consumption			30	mA	@25°C, $V_{cc} = 5.0V$ , $O_{load} = 15\text{ pF}$ .
	Supply Voltage	4.75	5.0	5.25	V	
Phase Noise	Phase Noise		-120		dBc/Hz	1KHz



Environmental Conditions	Operable Temperature	-40		+85	°C	
	Storage Temperature	-55		+105	°C	
	ESD Level	Human Body Model, class2: 2000V to 4000V; ANSI/ESDA/JEDEC JS-001-2010.				
		Machine Model, class B: 200V to 400V; ANSI/ESDA/JEDEC JS-001-2010.				
	Moisture Sensitivity Level	Not humidity sensitive.				
	Vibration	Test Condition: 0.75mm ;acceleration:10g;10Hz~2000Hz, one cycle per 30 min, test 2 hour. (3 times for each 3 directions X , Y , Z) .IEC 68-2-06 Test Fc.				
Shock	100g; 6ms; half sine wave (3 times for each 3 directions X , Y , Z ),IEC 68-2-27 Test Ea/Severity 50A.					

## 2. Mechanical Structure(mm)

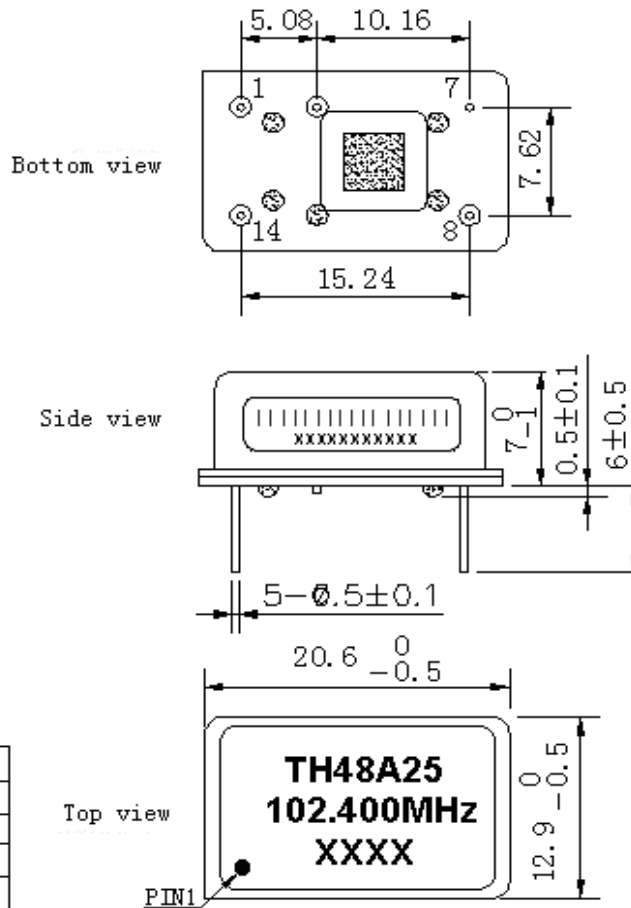

PIN FUNCTION

PIN	FUNCTION
1	NC
7	GND
8	OUTPUT
14	VCC

**Note1:** Tolerance ±0.2mm without mark

**Note2:** Referential Weight 4.2g

**Note3:** NC is not connect

**Note4:** The first two xx representative: week  
After two xx representative: year



### 3. Test circuit

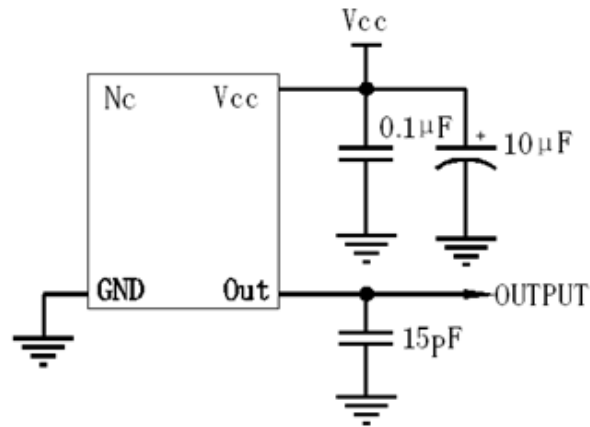

### 4. Wave Soldering Curve (RoHS)

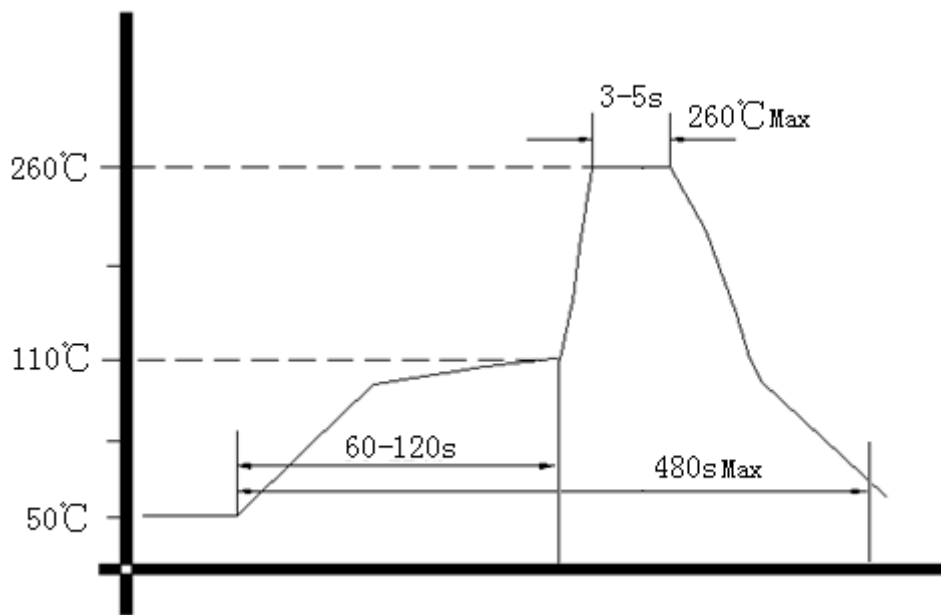

### 5. Package: PVC Tube, 10pcs (mm)

