

Travelling Merchant: _____

DATASHEET

Standard: **T22-S519-19.20MHz**

P/N: _____

| Plot | | | The Label |
|------------------|---------|----------|------------------------|
| Drew | Audited | Approved | Stamp, please! Thanks! |
| | | | |
| Date: 2017.11.28 | | | |

Guangdong Dapu Telecom Technology Co.,Ltd

Bldg13-16,.N.Ind.Zone,SSL Industry Park, Dongguan City, Guangdong Province, China

TEL: 0086-0769-88010888 FAX: 0086-0769-81800098



1、Electrical Parameters

| MODEL: T22-S519-19.20MHz | | | | | | |
|--------------------------|---|-------------------|------|-------|------------------|---|
| Item | Description | Parameters | | | Unit | Test Condition |
| | | Min. | Typ. | Max. | | |
| Output | Frequency | 19.20 | | | MHz | |
| | Output Waveform | Clipped Sine Wave | | | | |
| | Vp-p | 0.8 | | | V | |
| | Load | 10KΩ//10pF | | | | |
| Frequency Stabilities | Frequency Tolerance vs. Operating Temperature Range | -0.5 | | +0.5 | $\times 10^{-6}$ | T_A varied from -40°C to 85°C , measurement referenced to frequency observed with $T_A=25^{\circ}\text{C}$, $V_{cc}=3.3\text{V}$, $O_{load}=10\text{K}\Omega//10\text{pF}$, temperature variable speed less than 2°C per minute. |
| | Nominal Frequency Tolerance | 0 | | +1 | $\times 10^{-6}$ | Measurement referenced to frequency observed with $T_A=25^{\circ}\text{C}$, $V_{cc}=3.3\text{V}$, within 30 days after ex-works. |
| | Frequency Tolerance vs. Supply Voltage | -0.2 | | +0.2 | $\times 10^{-6}$ | measurement referenced to frequency observed $T_A=25^{\circ}\text{C}$, V_{cc} varied from 3.13V to 3.47V, and $O_{Load}=10\text{K}\Omega//10\text{pF}$. |
| | Frequency Tolerance vs. Load | -0.2 | | +0.2 | $\times 10^{-6}$ | 5% load change measurement referenced to frequency observed with $T_A=25^{\circ}\text{C}$, $V_{cc}=3.3\text{V}$, and $O_{Load}=10\text{K}\Omega//10\text{pF}$. |
| | Aging Tolerance Per Day | -0.02 | | +0.02 | $\times 10^{-6}$ | $T_A=25^{\circ}\text{C}$, $V_{cc}=3.3\text{V}$, and after 1h of operation. |
| | Aging Tolerance 1 Year | -1 | | +1 | $\times 10^{-6}$ | |
| Power Supply | Operating Current | | | 3 | mA | @ 25°C , $V_{cc}=3.3\text{V}$, $O_{Load}=10\text{K}\Omega//10\text{pF}$. |
| | Supply Voltage | 3.13 | 3.3 | 3.47 | V | |



| | | | | | | |
|-----------------------------|---|---|------|------|--------|--------|
| Phase Noise | Phase Noise | | -85 | -80 | dBc/Hz | 10Hz |
| | | | -115 | -110 | | 100Hz |
| | | | -135 | -130 | | 1KHz |
| | | | -145 | -140 | | 10KHz |
| | | | -148 | -143 | | 100KHz |
| | | | -148 | -143 | | 1MHz |
| Environmental Conditions | Operable Temperature | -40 | | +85 | °C | |
| | Storage Temperature | -55 | | +105 | °C | |
| | ESD Level | Human Body Model,class2: 2000V to 4000V; ANSI/ESDA/JEDEC JS-001-2010. | | | | |
| | | Machine Model, class B: 200V to 400V; ANSI/ESDA/JEDEC JS-001-2010. | | | | |
| | Moisture Sensitivity Level | Level 2 | | | | |
| | Vibration | Test Condition: 0.75mm ;acceleration:10g;10Hz~2000Hz, one cycle per 30 min, test 2 hour. (3 times for each 3 directions X , Y , Z) .IEC 68-2-06 Test Fc. | | | | |
| Shock | 100g; 6ms; half sine wave (3 times for each 3 directions X , Y , Z),IEC 68-2-27 Test Ea/Severity 50A. | | | | | |



2. Mechanical Structure(mm)

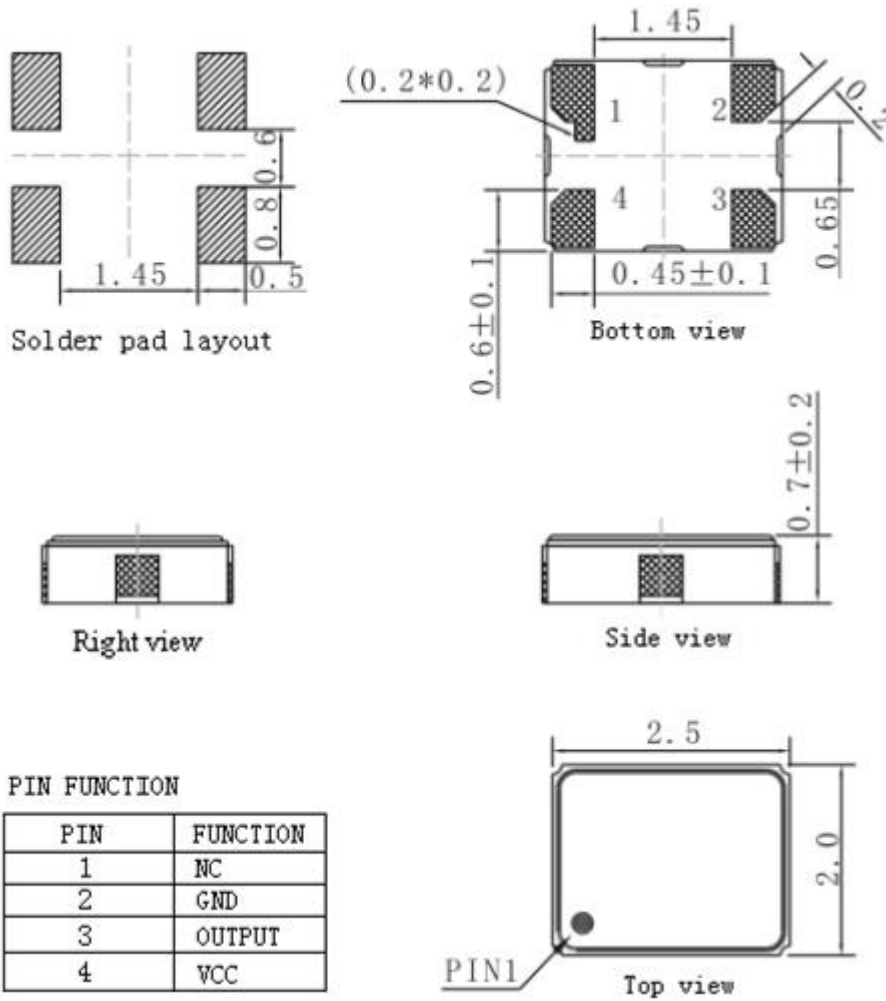

Note1: Tolerance $\pm 0.1\text{mm}$ without mark

Note2: Referential weight 0.01g

Note3: NC is not connect

3. Test Circuit

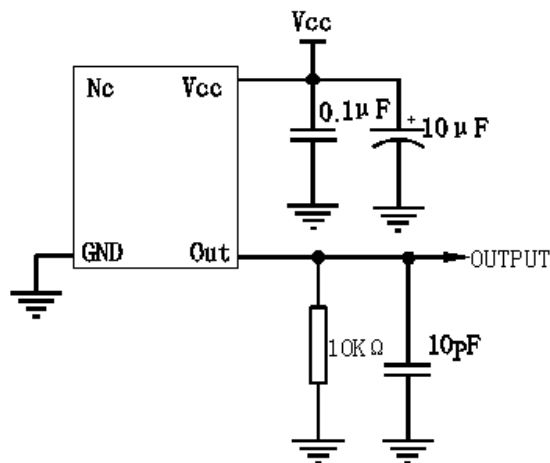



4. Reflow Soldering Curve (RoHS)



5. Package: Tape & Reel (mm)

