

Travelling Merchant: \_\_\_\_\_

# DATASHEET

Standard:           **O22B-L313-10.00MHz**          

P/N: \_\_\_\_\_

Plot			The Label
Drew	Audited	Approved	Stamp, please! Thanks!
Date: 2018.09.05			

## Guangdong Dapu Telecom Technology Co.,Ltd

Bldg13-16,.N.Ind.Zone,SSL Industry Park, Dongguan City, Guangdong Province, China

TEL: 0086-0769-88010888    FAX: 0086-0769-81800098





## 1. Electrical Parameters

MODEL: O22B-L313-10.00MHz						
Item	Description	Parameters			Unit	Test Condition
		Min.	Typ.	Max.		
Output	Frequency	10.00			MHz	
	Output Waveform	HCMOS				
	Output Low Voltage			0.4	V	$V_{cc}=3.3V, O_{load}=15pF$
	Output High Voltage	2.4			V	$V_{cc}=3.3V, O_{load}=15pF$
	Duty Cycle	45	50	55	%	@50%
	Rise / Fall Time (10%~90%)			8	ns	
	Load	15			pF	
Frequency Stabilities	Frequency Tolerance vs. Operating Temperature Range	-0.2		+0.2	$\times 10^{-6}$	$T_A$ varied from $-40^{\circ}C$ to $75^{\circ}C$ , measurement referenced to frequency observed with $f_{ref}=(f_{max}+f_{min})/2, V_{cc}=3.3V, V_c=1.5V, O_{load}=50\Omega$ , temperature variable speed less than $2^{\circ}C$ per minute.
	Initial Frequency Tolerance	-0.05		+0.05	$\times 10^{-6}$	Measurement referenced to frequency observed with $T_A=25^{\circ}C, V_{cc}=3.3V, V_c=1.5V$ and after 15 minutes of operation, within 30 days after ex-works.
	Frequency Tolerance vs. supply voltage	-5		+5	$\times 10^{-9}$	measurement referenced to frequency observed $T_A=25^{\circ}C, V_{cc}$ varied from 3.13V to 3.47V, $V_c=1.5V, O_{load}=50\Omega$ .
	Frequency Tolerance vs. Load	-5		+5	$\times 10^{-9}$	5% Load Change Measurement referenced to frequency observed with $T_A=25^{\circ}C, V_{cc}=3.3V, V_c=1.5V, O_{load}=50\Omega$ .
	Short Term Stability			0.01	$\times 10^{-9}$	Temperature stability, no EMI\EMC or other interference, test after power for 1hour ref. to $25^{\circ}C$ ; 1s, using PN9000 equipment.
	Aging Tolerance per day	-1		+1	$\times 10^{-9}$	$V_{cc}, V_c, T_A$ constant Measurement referenced to frequency observed with $T_A=25^{\circ}C, V_{cc}=3.3V, V_c=1.5V, O_{load}=50\Omega$ and after 30 days of operation.
	Aging Tolerance 1 Year	-0.1		+0.1	$\times 10^{-6}$	
Power Supply	Supply Voltage	3.13	3.3	3.47	V	
	Current Consumption			400	mA	@ $25^{\circ}C$
	Current Consumption during warm up			1000	mA	



Voltage Control Characteristics	Frequency Tuning Range	-1.0		-0.5	$\times 10^{-6}$	$V_c=0V$ . measurement referenced to $V_c=1.5V$ .
		-0.05		+0.05	$\times 10^{-6}$	$V_c=1.5V$ . measurement referenced to exactly 10.00MHz.
		+0.5		+1.0	$\times 10^{-6}$	$V_c=3.0V$ . measurement referenced to $V_c=1.5V$ .
	Linearity			10	%	
	Slope	Positive				
	Input Impedance	100				K $\Omega$
Phase Noise	Phase Noise		-120	-110	dBc/Hz	10Hz
			-140	-130		100Hz
			-150	-145		1KHz
			-155	-150		10KHz
			-155	-150		100KHz
Environmental Conditions	Operable Temperature	-40		+85	$^{\circ}C$	
	Storage Temperature	-55		+105	$^{\circ}C$	
	ESD Level	Human Body Model, class2: 2000V to 4000V; ANSI/ESDA/JEDEC JS-001-2010.				
		Machine Model, class B: 200V to 400V; ANSI/ESDA/JEDEC JS-001-2010.				
	Moisture Sensitivity Level	Not humidity sensitive.				
	Vibration	Test Condition: 0.75mm ;acceleration:10g;10Hz~500Hz, one cycle per 30 min, test 2 hour. (3 times for each 3 directions X ,Y , Z), IEC 68-2-06 Test Fc.				
Shock	50g; 11ms; half sine wave (3 times for each 3 directions X ,Y, Z ),IEC 68-2-27 Test Ea/Severity 50A.					
Full Package Storage	Relative humidity (%)	20%~70%				
	Temperature ( $^{\circ}C$ )	-10~35 $^{\circ}C$				



## 2. Mechanical Structure (mm)

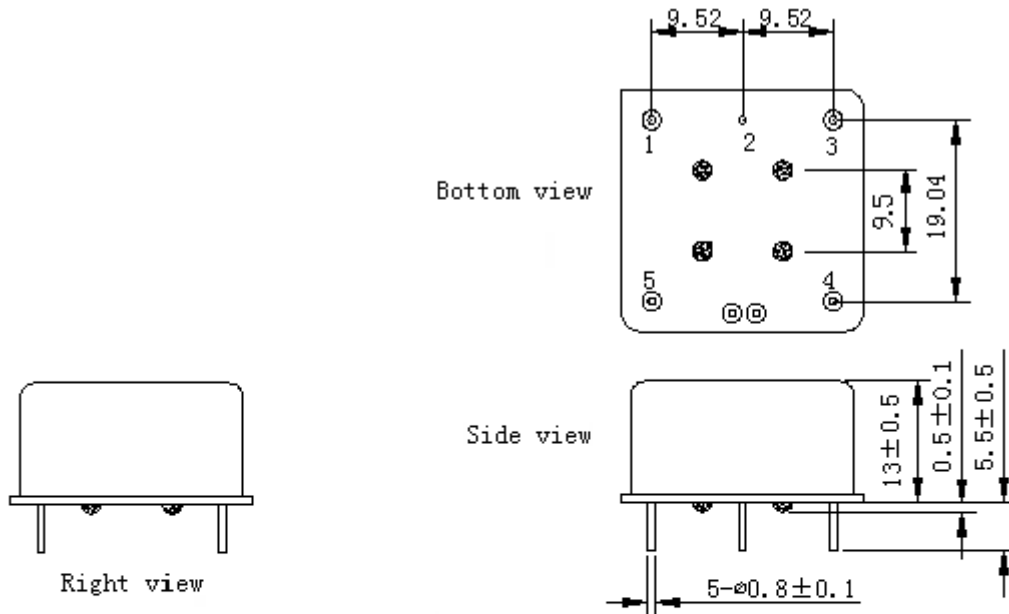

PIN FUNCTION

PIN	NOTATION	FUNCTION
1	OUTPUT	RF Output
2	GND	GND
3	VC	Control Voltage
4	NC	Not Connect
5	VCC	Supply Voltage

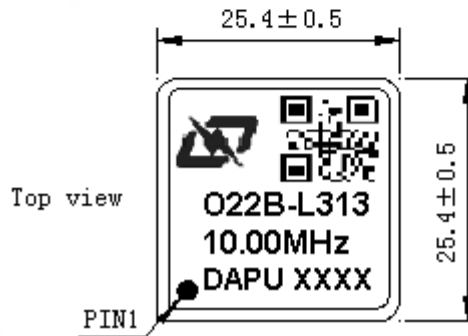

- Note1:** Tolerance ± 0.2mm without mark
- Note2:** The first two xx representative: week  
After two xx representative: year
- Note3:** Referential weight 13.6g
- Note4:** NC is not connect



### 3. Test Circuit

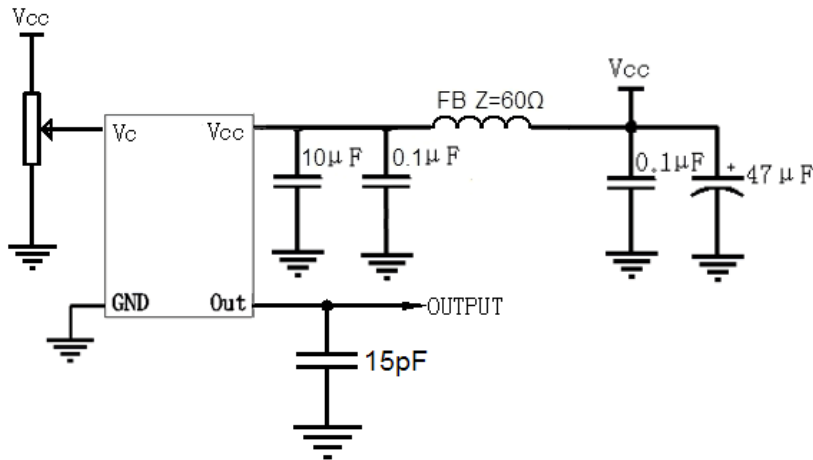

### 4. Reflow Soldering Curve (RoHS)

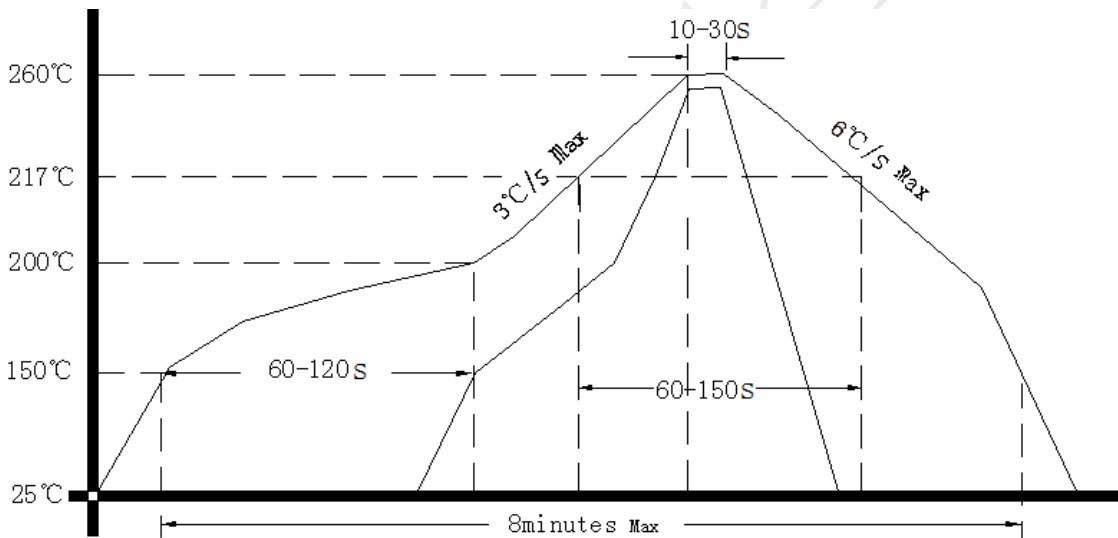

### 5. Package(mm)

