

Customer Code : _____

DATASHEET

DAPU P/N: M11A-MSAN-40.00MHz

Customer P/N: _____

DAPU			Customer Approval
Drew	Audited	Approved	Stamp, please! Thanks!
Date: 2015.08.14			

Guangdong Dapu Telecom Technology Co.,Ltd

Bldg 16,.N.Ind.Zone,SSL Industry Park, Dongguan City, Guangdong Province, China

TEL: 0086-0769-88010888 FAX: 0086-0769-81800098



1. Electrical Parameters

MODEL: M11A-MSAN-40.00MHz						
Item	Description	Parameters			Unit	Test Condition
		Min.	Typ.	Max.		
Output	Frequency	40.00			MHz	
	Output Waveform	Sine Wave				
	Pk-pk	2			V	
	Harmonics Suppression			-30	dBc	
	Spurious Suppression			-60	dBc	
	Load	1			KΩ	
Frequency Stabilities	Frequency Tolerance vs. Operating Temperature Range	-2		+2	$\times 10^{-6}$	T_A varied from -40°C to 85°C , measurement referenced to frequency observed with $T_A = 25^{\circ}\text{C}$, $V_{cc}=3.3\text{V}$, $O_{load}=1\text{K}\Omega$, temperature variable speed less than 2°C per minute.
	Initial Frequency Tolerance	-1		+1	$\times 10^{-6}$	Measurement referenced to frequency observed with $T_A = 25^{\circ}\text{C}$, $V_{cc}=3.3\text{V}$ within 30 days after ex-works.
	Frequency Tolerance vs. Supply Voltage	-0.1		+0.1	$\times 10^{-6}$	measurement referenced to frequency observed $T_A=25^{\circ}\text{C}$, V_{cc} varied from 3.13V to 3.47V, and $O_{Load}=1\text{K}\Omega$.
	Frequency Tolerance vs. Load	-0.1		+0.1	$\times 10^{-6}$	5% load change measurement referenced to frequency observed with $T_A= 25^{\circ}\text{C}$, $V_{cc}=3.3\text{V}$, $O_{Load}=1\text{K}\Omega$.
	Aging Tolerance Per Day	-0.02		+0.02	$\times 10^{-6}$	$T_A=25^{\circ}\text{C}$, $V_{cc}=3.3\text{V}$, and after 1h of operation.
	Aging Tolerance 1 Year	-1.5		+1.5	$\times 10^{-6}$	
Power Supply	Current Consumption		10		mA	@ 25°C , $V_{cc}=3.3\text{V}$, $O_{load}=1\text{K}\Omega$.
	Supply Voltage	3.13	3.3	3.47	V	
Phase Noise	Phase Noise		-125		dBc/Hz	1KHz



Environmental Conditions	Operable Temperature	-40		+85	°C	
	Storage Temperature	-55		+105	°C	
	ESD Level	Human Body Model, class2: 2000V to 4000V; ANSI/ESDA/JEDEC JS-001-2010.				
		Machine Model, class B: 200V to 400V; ANSI/ESDA/JEDEC JS-001-2010.				
	Moisture Sensitivity Level	Not humidity sensitive.				
	Vibration	Test Condition: 0.75mm ;acceleration:10g;10Hz~500Hz~10Hz, test 1 hour. (in 3 directions X ,Y , Z), GJB 360B-2009 Test Ea 204.				
Shock	100g; 6ms; half sine wave (3 times for each 3 directions X ,Y , Z), GJB 360B-2009 Test Ea 213					
Full Package Storage	Relative humidity (%)	20%~70%				
	Temperature (°C)	-10~35°C				

2. Mechanical Structure(mm)

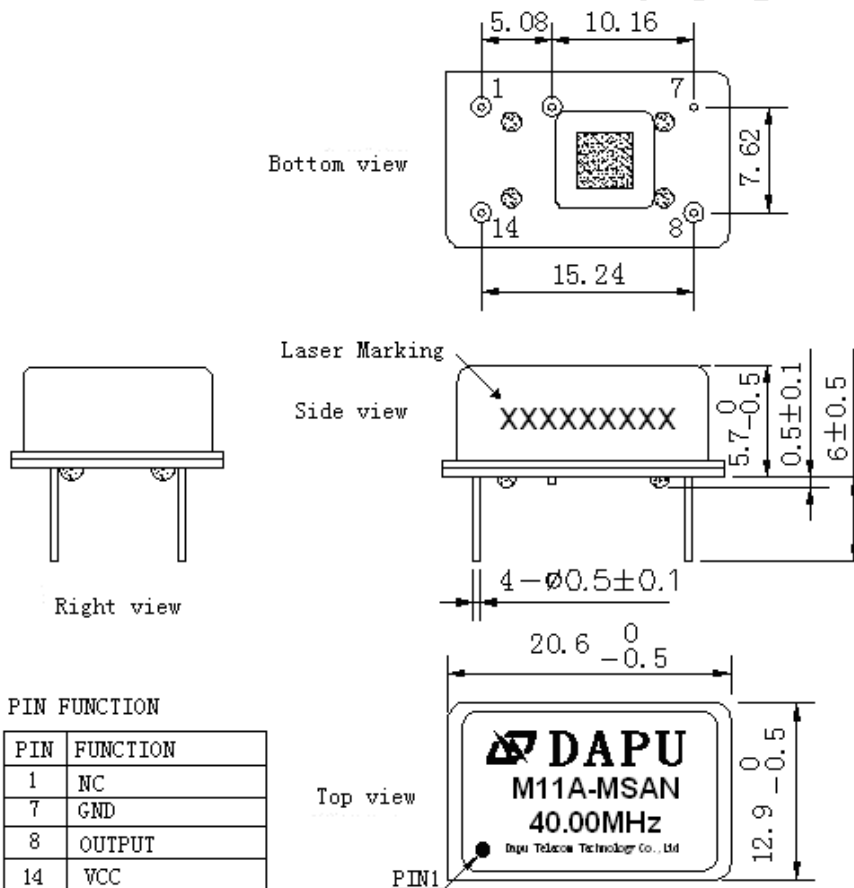

Note1: Tolerance $\pm 0.20\text{mm}$ without mark

Note2: Referential Weight 4.2g

Note3: NC is not connect

Note4: Laser marking explanation: The first six X representative: (year) (month) (date)
After three X representative: Serial number



3. Test circuit

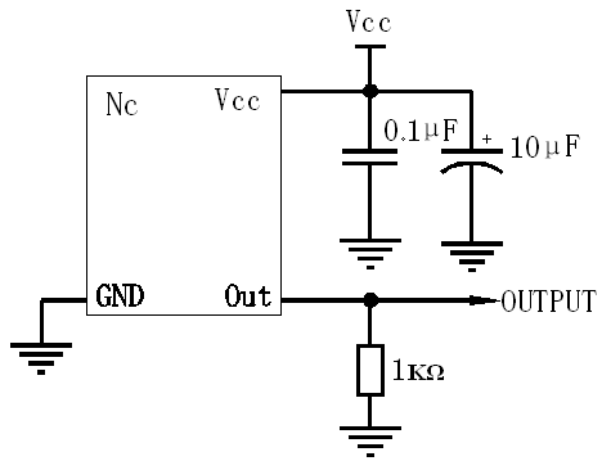

4. Reflow Soldering Curve

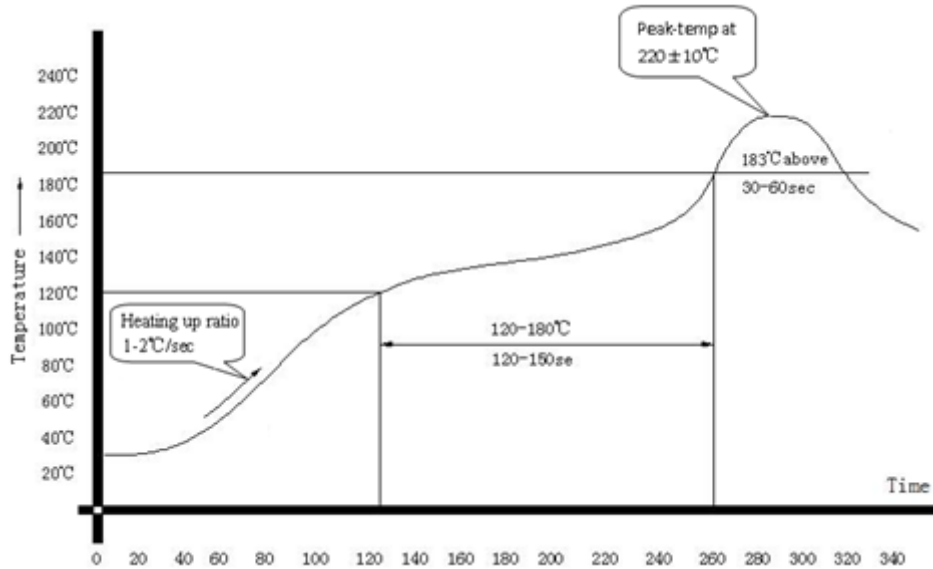

5. Package: PVC Tube,10pcs (mm)

