

Customer Code : \_\_\_\_\_

# DATASHEET

DAPU P/N :     **T53-Q311-20.00MHz**    

Customer P/N: \_\_\_\_\_

DAPU			Customer Approval
Drew	Audited	Approved	Stamp, please! Thanks!
Date: 2017.05.31			

## Guangdong Dapu Telecom Technology Co.,Ltd

Bldg13-16,.N.Ind.Zone,SSL Industry Park, Dongguan City, Guangdong Province, China

TEL: 0086-0769-88010888 FAX: 0086-0769-81800098





## 1. Electrical Parameters

MODEL: T53-Q311-20.00MHz						
Item	Description	Parameters			Unit	Test Condition
		Min.	Typ.	Max.		
Output	Frequency	20.00			MHz	
	Output Waveform	CMOS				
	Output Low Voltage			0.33	V	$V_{cc}=3.3V, O_{load}=15pF$
	Output High Voltage	2.97			V	$V_{cc}=3.3V, O_{load}=15pF$
	Duty Cycle	40	50	60	%	@50%
	Rise / Fall Time (10%~90%)			6	ns	
	Start time			2	ms	
	Load	15			pF	
Frequency Stabilities	Frequency Tolerance vs. Operating Temperature Range	-0.28		+0.28	$\times 10^{-6}$	$T_A$ varied from -40 to 85°C, measurement referenced to frequency observed with $f_{ref}=(f_{max}+f_{min})/2, V_{cc}=3.3V, V_c=1.5V, O_{load}=15pF$ , temperature variable speed less than 2°C per minute.
	Initial Frequency Tolerance	-2		+2	$\times 10^{-6}$	Measurement referenced to frequency observed with $T_A=25^\circ C, V_{cc}=3.3V, V_c=1.5V$ within 30 days after ex-works.
	Frequency Tolerance vs. Supply Voltage	-0.3		+0.3	$\times 10^{-6}$	measurement referenced to frequency observed $T_A=25^\circ C, V_{cc}$ varied from 3.135V to 3.465V, $V_c=1.5V$ and $O_{Load}=15pF$ .
	Frequency Tolerance vs. Load	-0.2		+0.2	$\times 10^{-6}$	5% load change measurement referenced to frequency observed with $T_A=25^\circ C, V_{cc}=3.3V, V_c=1.5V, O_{Load}=15pF$ .
	Aging Tolerance 1 Year	-2.5		+2.5	$\times 10^{-6}$	20 years at 25 °C
Power Supply	Current Consumption			5	mA	@25°C, $V_{cc}=3.3V, V_c=1.5V, O_{load}=15pF$ .
	Supply Voltage	3.135	3.3	3.465	V	
Phase Noise	Phase Noise		-120		dBc/Hz	100Hz
			-140			1KHz
			-153			10KHz
			-156			100KHz



Voltage Control Characteristics	Frequency Tuning Range	-10		-5	$\times 10^{-6}$	$V_c=0.5V$ . measurement referenced to $V_c=1.5V$
		-2		+2	$\times 10^{-6}$	$V_c=1.5V$ . measurement referenced to exactly 20.00MHz
		+5		+10	$\times 10^{-6}$	$V_c=2.5$ . measurement referenced to $V_c=1.5V$
	Linearity			10	%	
	Slope	Positive				
	Input Impedance	100				K $\Omega$
Environmental Conditions	Operable Temperature	-40		+85	$^{\circ}C$	
	Storage Temperature	-55		+125	$^{\circ}C$	
	Vibration Test	MIL-STD-883 2007 Condition A JESD22-B103 Condition 1				10~2000Hz, 1.52mm, 20G, each axis for 4 hrs
	Thermal Shock	MIL-STD-883 1010 Condition B JESD22-A104 Condition B				-55 $^{\circ}C$ , 125 $^{\circ}C$ ; soak time is 10 mins, with total 200 cycles
	Mechanical Shock	MIL-STD-883 2002 Condition B JESD22-B104 Condition B				1500G, half-sine, 0.5ms, each axis for 3 times.



## 2. Mechanical Structure(mm)

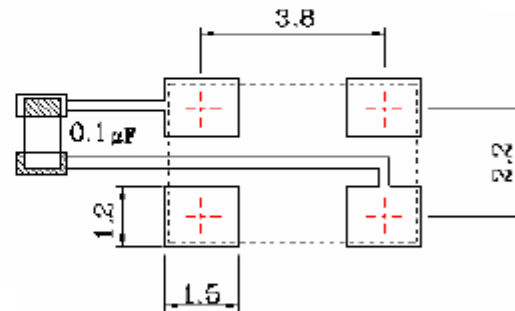
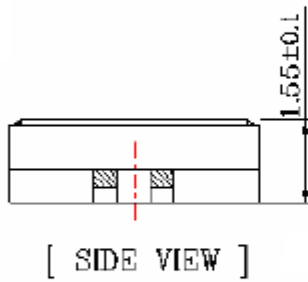
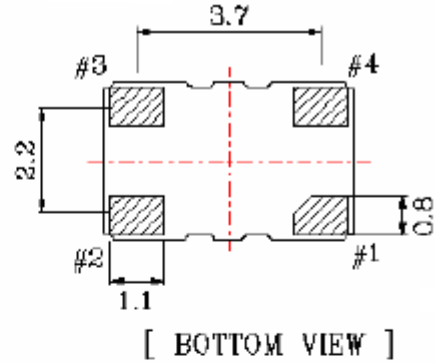
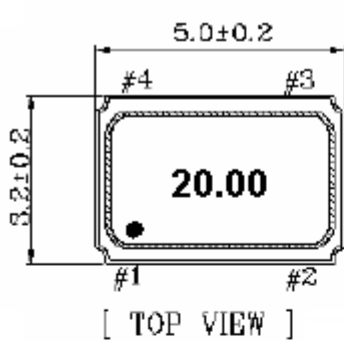

Recommended soldering pattern  
\*To ensure optimal oscillator performance,  
place a by-pass capacitor of 0.1µF as  
close to the part as possible between  
Vdd and GND pads.

### > PIN FUNCTIONS

Pin	Function
#1	VCON
#2	GND
#3	Output
#4	Vdd

Unit : mm

Note1: Tolerance ±0.1mm without mark

## 3. Test circuit

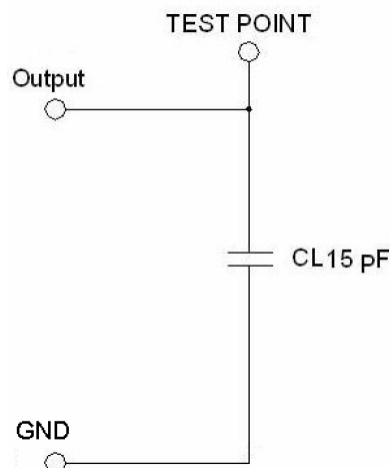



#### 4. Output Waveform

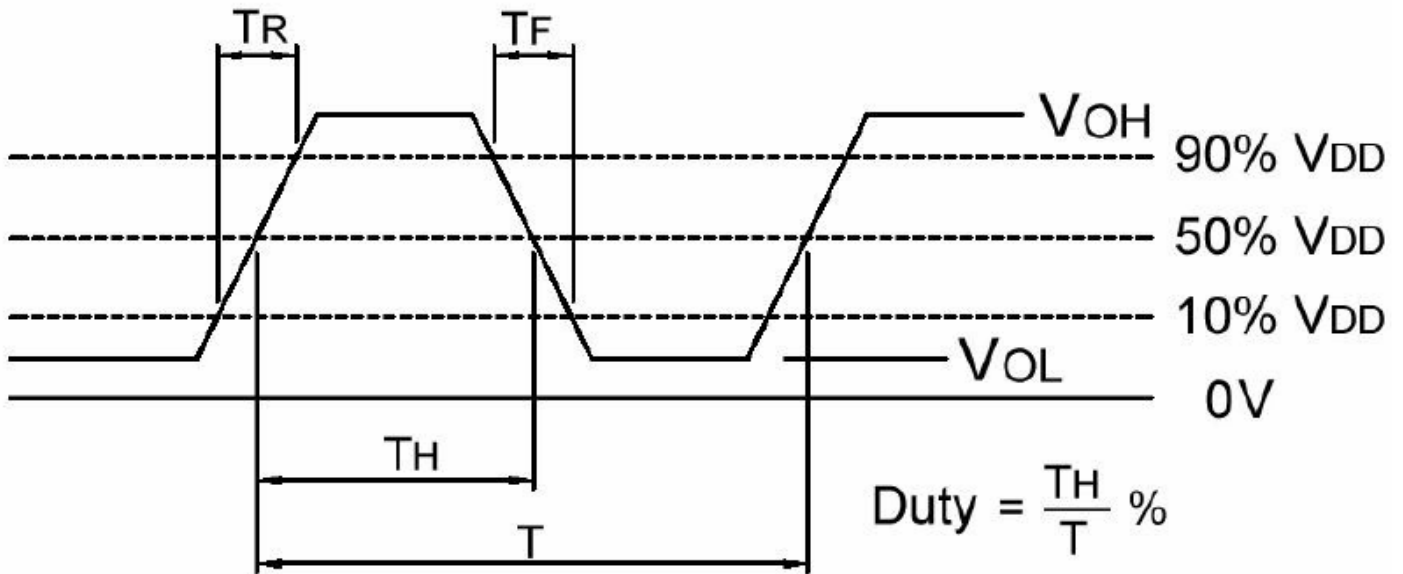

#### 5. Recommended Ir Reflow Profile

➤ IR REFLOW PROFILE OF CERAMIC SMD PRODUCTS FOR Pb FREE PROCESS

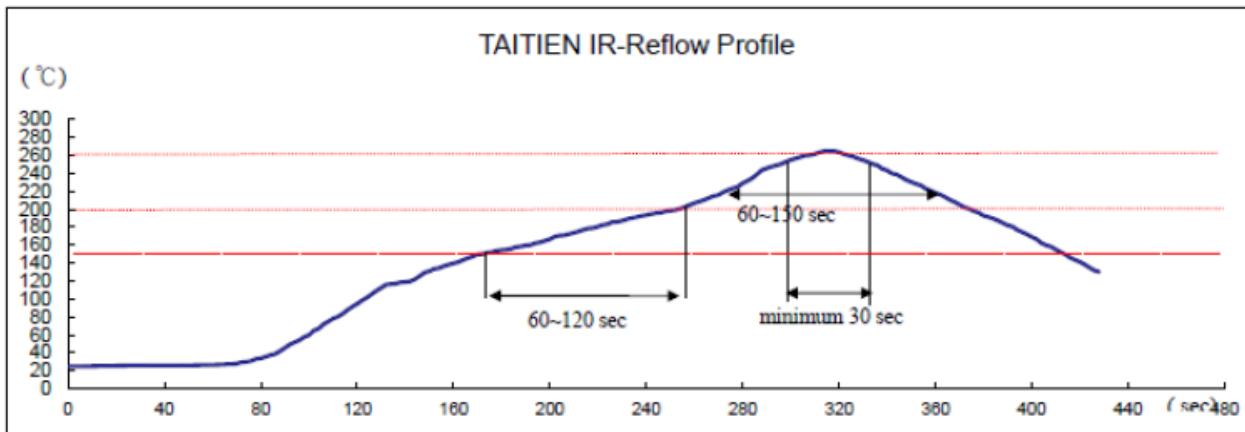

Reference Standard: JEDEC-STD 020

Test conditions: Pre-heating : 150°C to 200°C, 60~120secs.

Heating : 217°C, 60~150sec.

Peak temperature at least : 260°C, The time above 255 °C : minimum 30sec.



## 6. Package: Tape & Reel (mm)

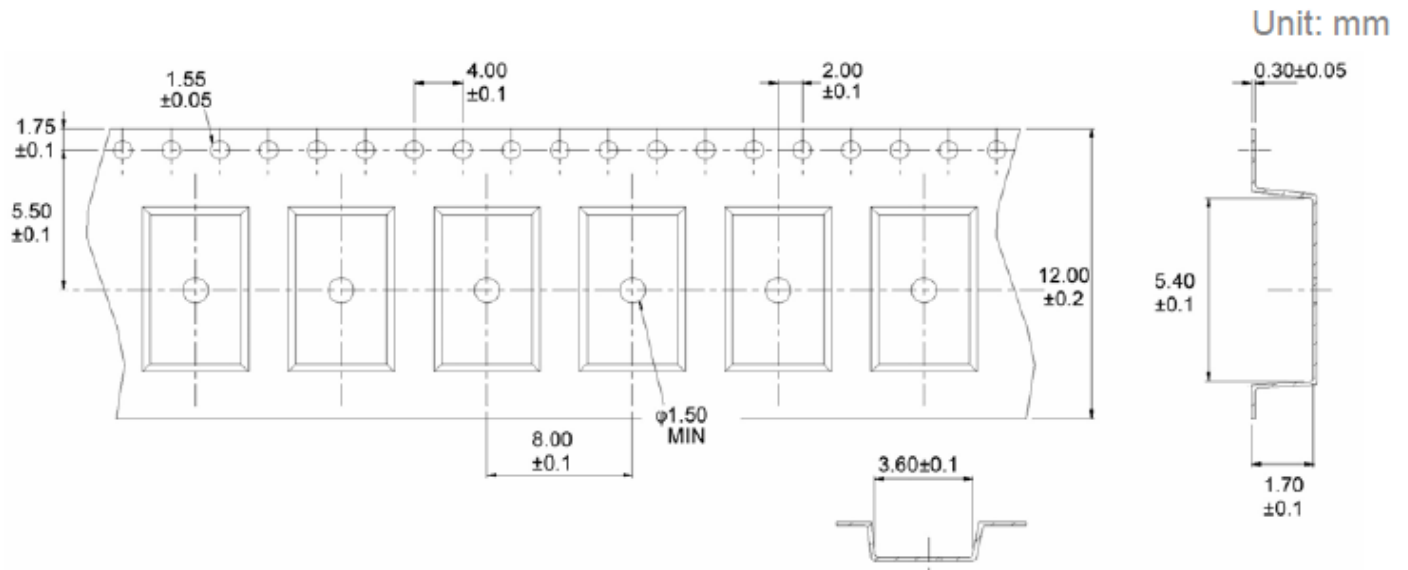

DAPU Confidential