

Travelling Merchant: _____

DATASHEET

Standard: **V53-E313-76.80MHz**

P/N: _____

Plot			The Label
Drew	Audited	Approved	Stamp, please! Thanks!
Date: 2018.04.26			

Guangdong Dapu Telecom Technology Co.,Ltd

Bldg13-16,.N.Ind.Zone,SSL Industry Park, Dongguan City, Guangdong Province, China

TEL: 0086-0769-88010888 FAX: 0086-0769-81800098



Table of amendment

Version	Revision contents	Prepared by	Revised date
1.0	The first issued	<i>Amway</i>	2017.09.26
1.1	The” Mechanical Structure” changed	<i>Amway</i>	2018.04.26



1. Electrical Parameters

MODEL: V53-E313-76.80MHz						
Item	Description	Parameters			Unit	Test Condition
		Min.	Typ.	Max.		
Output	Frequency	76.80			MHz	
	Output Waveform	HCMOS				
	Output Low Voltage			0.33	V	$V_{cc}=3.3V, O_{load}=15\text{ pF}$
	Output High Voltage	2.97			V	$V_{cc}=3.3V, O_{load}=15\text{ pF}$
	Duty Cycle	40	50	60	%	@1.65V
	Rise / Fall Time (10%~90%)			6	ns	@25°C
	Start Time			10	ms	@+3.135V
	Load	15			pF	
Frequency Stabilities	Frequency Stability	-35		+35	$\times 10^{-6}$	Include Freq. Tolerance, Temp., Supply voltage, Load.
	Aging Tolerance 1 Year	-5		+5	$\times 10^{-6}$	PER YEAR (AT 25 °C $\pm 5^{\circ}\text{C}$)
Power Supply	Current Consumption			30	mA	@25°C, $V_{cc}=3.3V, V_c=1.65V, O_{load}=15\text{pF}$.
	Supply Voltage	3.13	3.3	3.47	V	



Voltage Control Characteristics	Frequency Tuning Range	-150		-80	$\times 10^{-6}$	$V_c=0.15$ measurement referenced to 15 $V_c=1.65V$
		-15		+15	$\times 10^{-6}$	$V_c=1.65V$. measurement referenced to exactly 76.80MHz
		+80		+150	$\times 10^{-6}$	$V_c=3.15V$. measurement referenced to $V_c=1.65V$
	Linearity			10	%	
	Slope	Positive				
	Input Impedance	100				K Ω
Environmental Conditions	Operable Temperature	-40		+85	$^{\circ}C$	
	Storage Temperature	-55		+105	$^{\circ}C$	
	ESD Level	Human Body Model, class2: 2000V to 4000V; ANSI/ESDA/JEDEC JS-001-2010.				
		Machine Model, class B: 200V to 400V; ANSI/ESDA/JEDEC JS-001-2010.				
	Moisture Sensitivity Level	Level 2.				
	Vibration	Test Condition: 0.75mm; acceleration:10g;10Hz~2000Hz, one cycle per 30 min, test 2 hour. (3 times for each 3 directions X , Y , Z).IEC 68-2-06 Test Fc.				
Shock	100g; 6ms; half sine wave (3 times for each 3 directions X , Y , Z),IEC 68-2-27 Test Ea/Severity 50A.					



2. Mechanical Structure(mm)

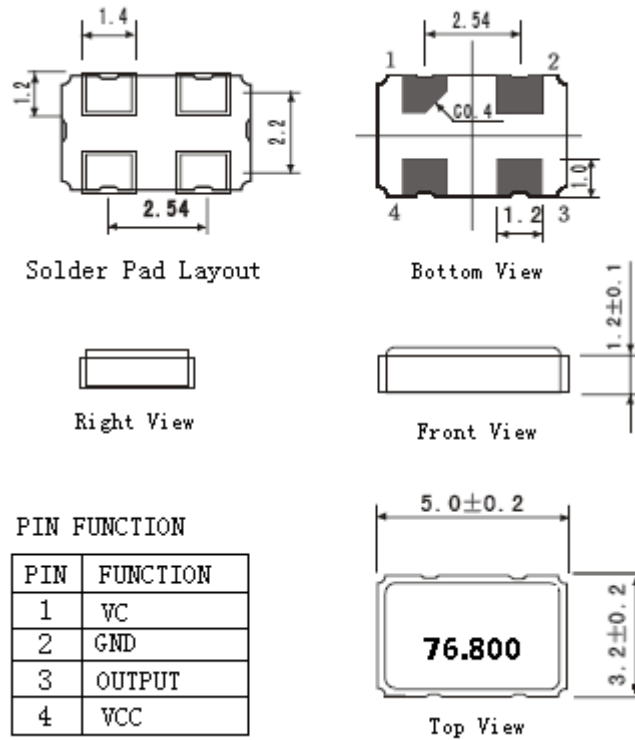

Note1: Tolerance $\pm 0.1\text{mm}$ without mark

Note2: Referential Weight 0.1g

3. Test circuit

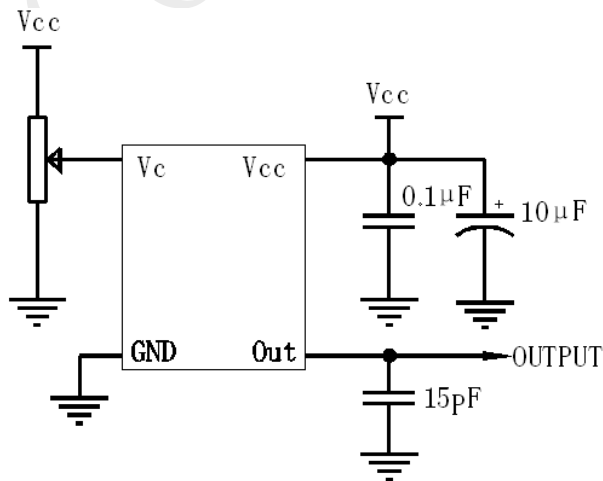



4. Reflow Soldering Curve (RoHS)

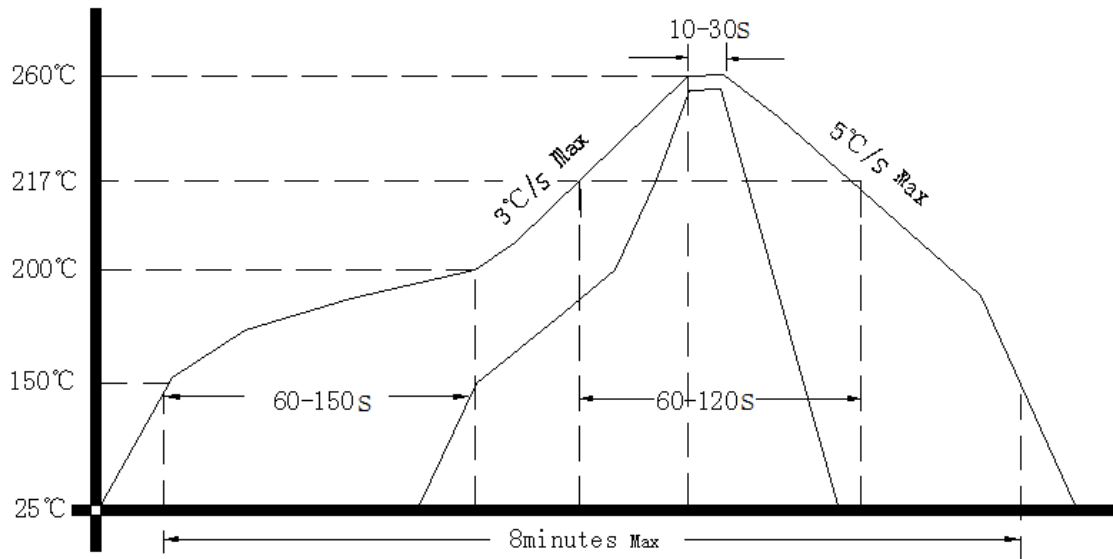

5. Package: Tape & Reel (mm)

