

Travelling Merchant: _____

DATASHEET

Standard: **O22S-F428-10.00MHz**

P/N: _____

Plot			The Label
Drew	Audited	Approved	
Date: 2017.08.16			Stamp, please! Thanks!

Guangdong Dapu Telecom Technology Co.,Ltd

Bldg13-16,.N.Ind.Zone,SSL Industry Park, Dongguan City, Guangdong Province, China

TEL: 0086-0769-88010888 FAX: 0086-0769-81800098



1、Electrical Parameters

MODEL: O22S-F428-10.00MHz						
Item	Description	Parameters			Unit	Test Condition
		Min.	Typ.	Max.		
Output	Frequency	10.00			MHz	
	Output Waveform	Sine wave				
	Level	6		10	dBm	
	Load	50			Ω	
	Harmonics Suppression			-40	dBc	
	Spurious Suppression			-70	dBc	
Frequency Stabilities	Frequency Tolerance vs. Operating Temperature Range	-5.0		+5.0	$\times 10^{-9}$	T_A varied from -0°C to 60°C , measurement referenced to frequency observed with $T_{f_{ref}}=(f_{max}+f_{min})/2$, $V_{cc}=5.0\text{V}$, $V_c=2.5\text{V}$, $O_{load}=50\Omega$, temperature rise speed less than 2°C per minute.
	Initial Frequency Tolerance	-0.2		+0.2	$\times 10^{-6}$	Measurement referenced to frequency observed with $T_A=25^{\circ}\text{C}$, $V_{cc}=5.0\text{V}$, $V_c=2.5\text{V}$, and after 15 minutes of operation, within 30 days after ex-works
	Frequency Tolerance vs. Supply Voltage	-2.0		+2.0	$\times 10^{-9}$	measurement referenced to frequency observed $T_A=25^{\circ}\text{C}$, V_{cc} varied from 4.75V to 5.25V, $V_c=2.5\text{V}$ and $O_{Load}=50\Omega$.
	Frequency Tolerance vs. Load	-2.0		+2.0	$\times 10^{-9}$	5% load change measurement referenced to frequency observed with $T_A=25^{\circ}\text{C}$, $V_{cc}=5.0\text{V}$, $V_c=2.5\text{V}$ and $O_{Load}=50\Omega$.
	Short-Term Stability: Allan Variance			0.01	$\times 10^{-9}$	Temperature stability, no EMI\EMC or other interference, test after power for 1hour ref. to 25°C ; 1s, using PN9000 equipment.
	Aging Tolerance Per Day	-0.5		+0.5	$\times 10^{-9}$	V_{cc} , V_c , T_A constant measurement referenced to frequency observed with $T_A=25^{\circ}\text{C}$, $V_{cc}=5.0\text{V}$, $V_c=2.5\text{V}$, and after 30 days of operation.
	Aging Tolerance 1 Year	-0.05		+0.05	$\times 10^{-6}$	
Power Supply	Supply Voltage	4.75	5.0	5.25	V	
	Steady Consumption			250	mA	@ 25°C
	Warm up Current			600	mA	



Voltage Control Characteristics	Frequency Tuning Range			-1.0	$\times 10^{-6}$	$V_c = 0$ V. measurement referenced to $V_c = 2.5$ V
		-0.2		+0.2	$\times 10^{-6}$	$V_c = 2.5$ V. measurement referenced to exactly 10.00 MHz
		+1.0			$\times 10^{-6}$	$V_c = 5.0$ V. measurement referenced to $V_c = 2.5$ V
	Linearity			10	%	
	Slope	Positive				
	Input Impedance	100				K Ω
Phase Noise	Phase Noise		-90	-80	dBc/Hz	1Hz
			-120	-110		10Hz
			-140	-130		100Hz
			-145	-140		1KHz
			-150	-145		10KHz
			-150	-145		100KHz
Environmental Conditions	Operable Temperature	-0		+60	$^{\circ}$ C	
	Storage Temperature	-55		+105	$^{\circ}$ C	
	ESD Level	Human Body Model, class2: 2000V to 4000V; ANSI/ESDA/JEDEC JS-001-2010.				
		Machine Model, class B: 200V to 400V; ANSI/ESDA/JEDEC JS-001-2010.				
	Moisture Sensitivity Level	Level 2.				
	Vibration	Test Condition: 0.75mm ;acceleration:10g;10Hz~500Hz, one cycle per 30 min, test 2 hour. (3 times for each 3 directions X ,Y , Z), IEC 68-2-06 Test Fc.				
Shock	50g; 11ms; half sine wave (3 times for each 3 directions X ,Y, Z),IEC 68-2-27 Test Ea/Severity 50A.					
Full Package Storage	Relative humidity (%)	20% ~ 70%				
	Temperature ($^{\circ}$ C)	-10~35 $^{\circ}$ C				



2、 Mechanical Structure(mm)

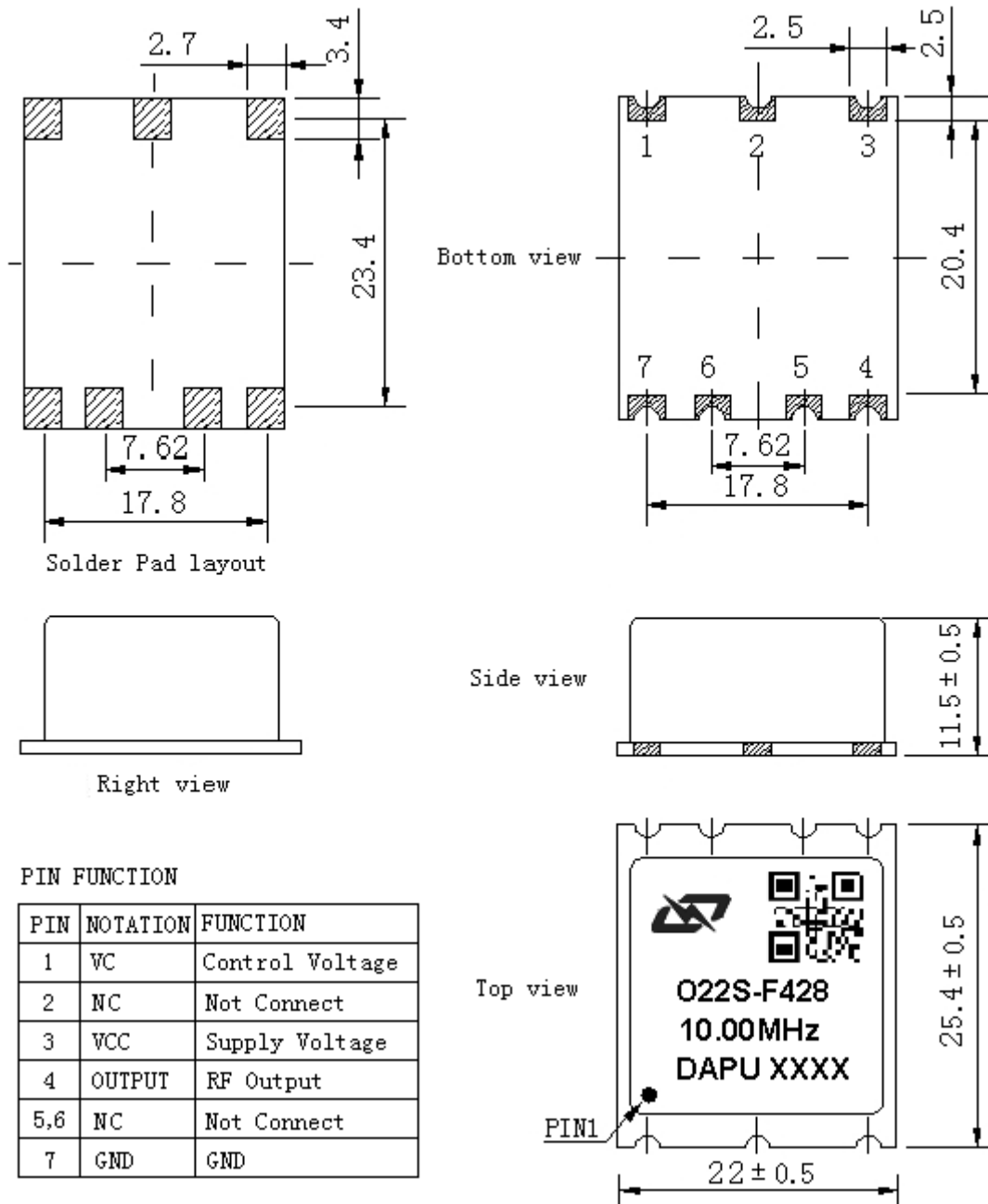

- Note1:** Tolerance $\pm 0.2\text{mm}$ without mark
- Note2:** Referential weight 7.8g
- Note3:** NC is not connect
- Note4:** The first two xx representative: week
After two xx representative: year



3、 Test Circuit

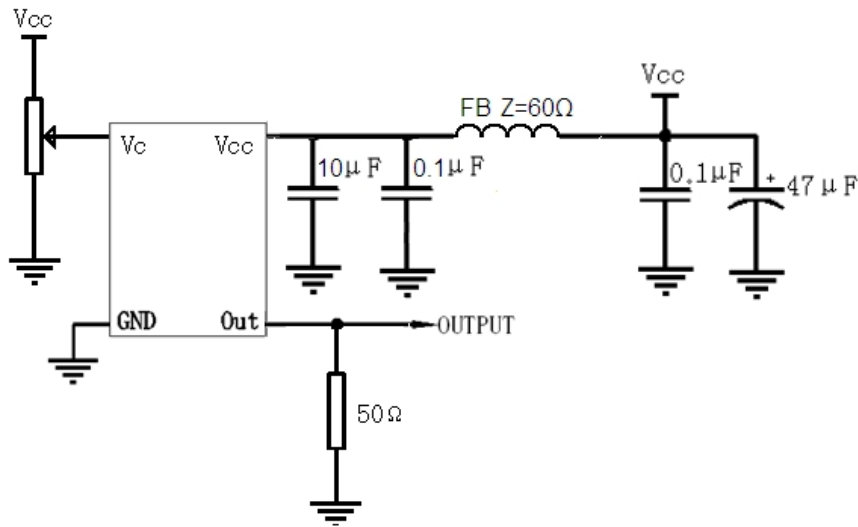

4、 Reflow Soldering Curve (RoHS)

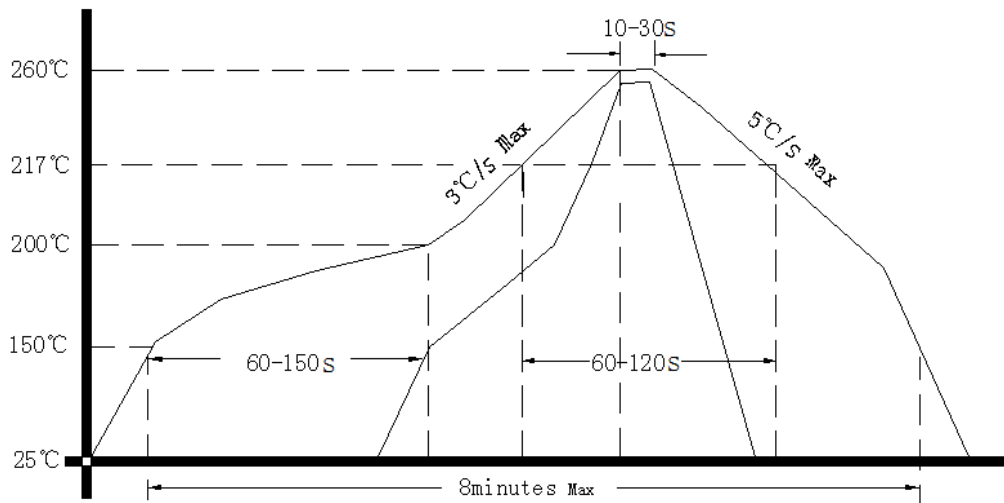

5、 Package: Tape & Reel (mm)

