

Travelling Merchant: \_\_\_\_\_

# DATASHEET

Standard: DP7W66667001

Plot			The Label
Drew	Audited	Approved	Stamp, please! Thanks!
Date: 2017.08.16			

## Guangdong Dapu Telecom Technology Co.,Ltd

Bldg13-16,.N.Ind.Zone,SSL Industry Park, Dongguan City, Guangdong Province, China

TEL: 0086-0769-88010888 FAX: 0086-0769-81800098



## 1、Electrical Parameters

MODEL: DP7W66667001							
No.	Parameters	SYM.	Electrical Spec.				Notes
			Min.	Typ.	Max.	Units	
1	Nominal Frequency	FL	66.667			MHz	
2	Frequency Stability	-	-50	~	+50	$\times 10^{-6}$	incl. 25 °C tolerance, tolerance over operating temperature range, input voltage change, load change, 1 year aging
3	Operating Temperature	Topr	-20		70	°C	
4	Storage Temperature	Tstg	-55	~	125	°C	
5	Supply Voltage	VDD	3.3 ± 10%			V	
6	Input Current	Icc	-	-	20	mA	
7	Output State Control	-	Enable/Disable			-	
8	Output Load: CMOS	CL	15			pF	
9	Output Voltage High	VoH	90% Vdd	-	-	V	
10	Output Voltage Low	Vol	-	-	10% Vdd	V	
11	Rise/ Fall Time	Tr/ Tf	-	-	4	ns	
13	Symmetry (Duty ratio)	TH/T	45	~	55	%	
14	Start-up Time	Tosc	-	-	10	ms	
15	Oscillation mode:		Overtone			V	
17	Aging	-	±3			$\times 10^{-6}$ /yr.	1st. Year at 25°C
18	Standby Current		-	-	10	μ A	
19	Phase Jitter (rms)		-	-	1	ps	12kHz to 20MHz
20	ESD Level	Human Body Model,class2: 2000V to 4000V; ANSI/ESDA/JEDEC JS-001-2010.					
		Machine Model, class B: 200V to 400V; ANSI/ESDA/JEDEC JS-001-2010.					
21	Moisture Sensitivity Level	Level 2.					
22	Vibration	Test Condition: 0.75mm ;acceleration:10g;10Hz~2000Hz, one cycle per 30 min, test 2 hour. (3 times for each 3 directions X , Y , Z) .IEC 68-2-06 Test Fc.					
23	Shock	100g; 6ms; half sine wave (3 times for each 3 directions X , Y , Z ),IEC 68-2-27 Test Ea/Severity 50A.					



## 2、Mechanical Structure(mm)

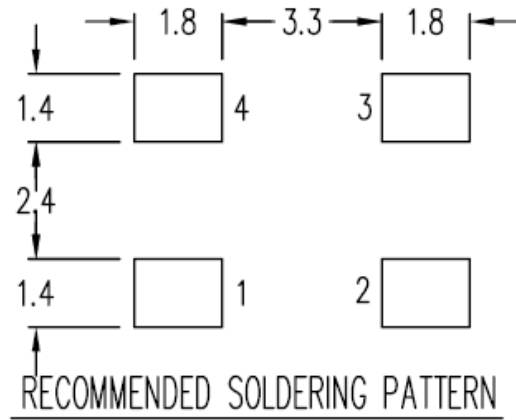
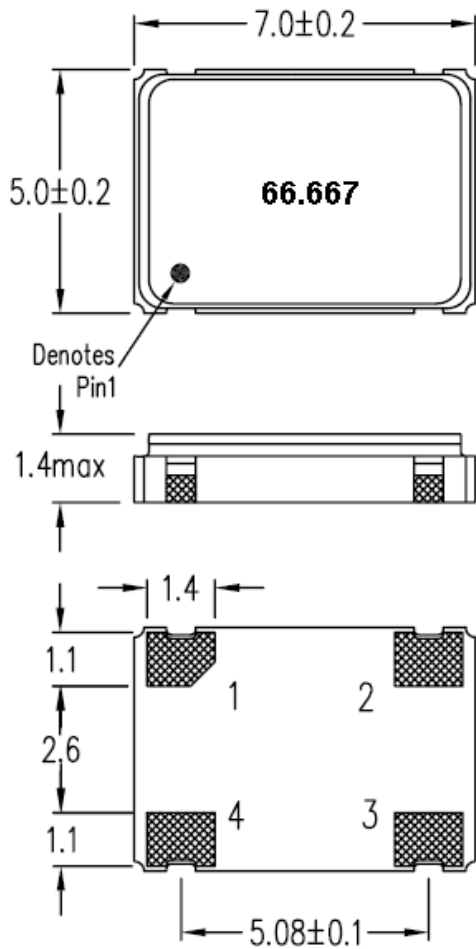

### PIN CONNECTION

1	Enable/Disable*
2	GND
3	Output
4	VDD

\* Enable/Disable functional description  
When pin1 goes high ( $\geq 0.7VDD$ ) or open, the Oscillator in normal operation and has output in frequency. When pin1 goes low ( $\leq 0.3VDD$ ), the oscillator stops and the oscillator output (Pin3) becomes high impedance.

Note1: Tolerance  $\pm 0.2mm$  without mark

## 3、Test Circuit

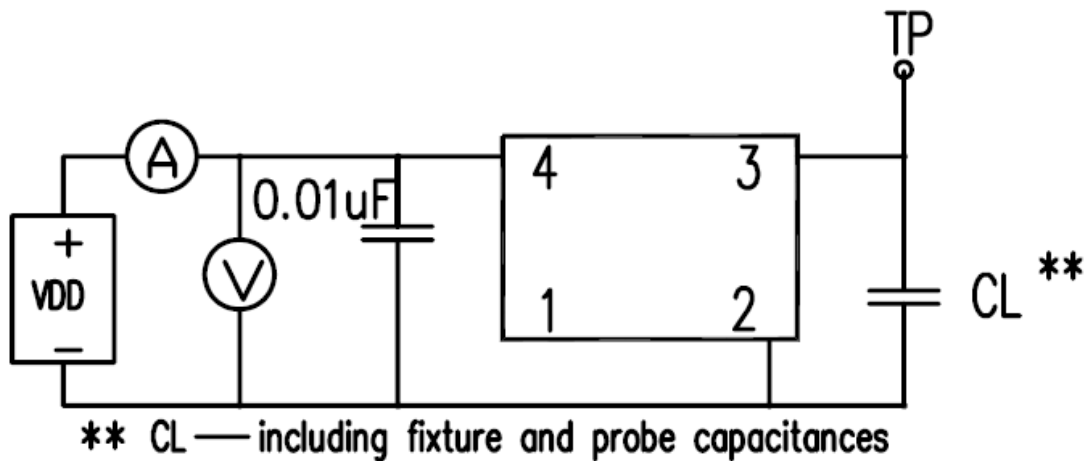



### 4、 Recommended Reflow Soldering Condition (SMD)

Peak: 260°C±5°C Soldering zone: 217°C or more  
60s~150s,Pre-heating zone 1: 150~200°C, 60s~180s

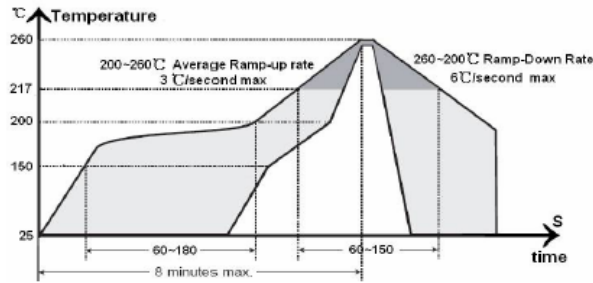

Temperature profile for reflow soldering

### 5、 Package: Tape & Reel (mm)

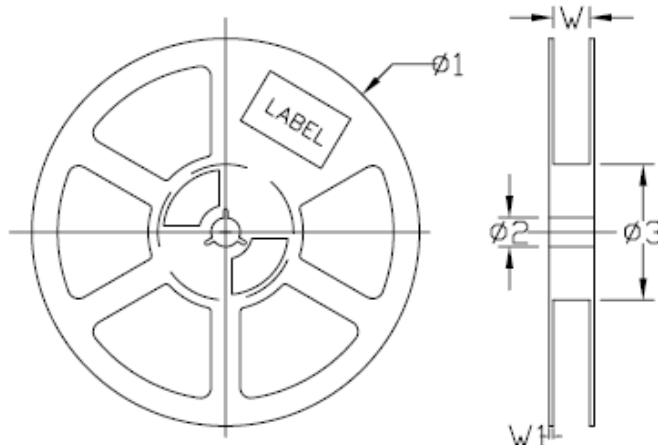

REEL DIMENSIONS

ITEM	$\phi 1 \pm 0.5$	$\phi 2 \pm 0.25$	$\phi 3 \pm 0.3$	$W \pm 0.2$	$W1 \pm 0.25$
16mm	178	13.2	62.5	16.4	2

LABEL: IQG P/N: xxxxxxxxxxxxxxxxxxxxxx  
Freq: ff. fff  
Qty: xxxx PCS

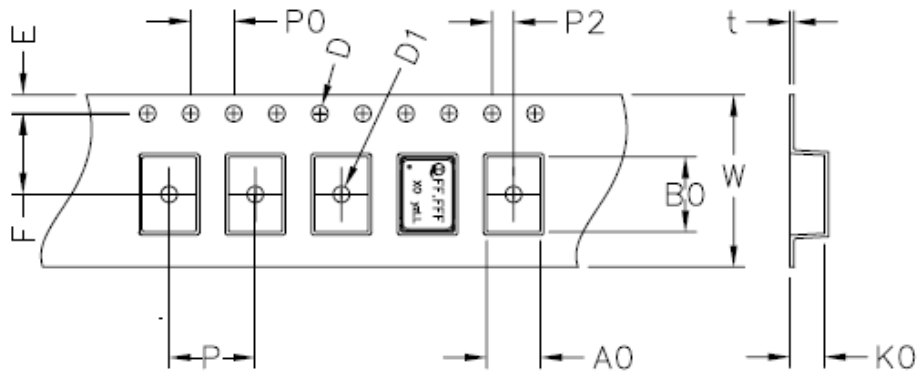

EMBOSSED TYPE DIMENSIONS

ITEM	$W \pm 0.3/0.1$	$A0 \pm 0.1$	$B0 \pm 0.1$	$K0 \pm 0.1$	$P \pm 0.1$	$F \pm 0.1$	$t \pm 0.05$	Qty
149	16.0	5.5	7.5	2.0	8.0	7.5	0.3	1000

$E=1.75 \pm 0.1$ ,  $D=1.5 \pm 0.1$ ,  $D1=1.5+0.25/-0.0$ ,  $P0=4.0 \pm 0.1$ ,  $P2=2.0 \pm 0.1$