

Travelling Merchant: \_\_\_\_\_

# DATASHEET

Standard: DP7X2700005

2PY32NN27001/ Y32NN27001

Plot			The Label
Drew	Audited	Approved	Stamp, please! Thanks!
Date: 2017.04.05			

## Guangdong Dapu Telecom Technology Co.,Ltd

Bldg13,.N.Ind.Zone,SSL Industry Park, Dongguan City, Guangdong Province, China

TEL: 0086-0769-88010888 FAX: 0086-0769-81800098



## 1、Electrical Parameters

MODEL: DP7X27000005							
No.	Parameters	SYM.	Electrical Spec.				Notes
			Min.	Typ.	Max.	Units	
1	Nominal Frequency	FL	27.00			MHz	
2	Frequency Stability	-	-30		+30	$\times 10^{-6}$	incl. 25 °C tolerance, tolerance over operating temperature range, input voltage change, load change, 1 year aging
3	Operating Temperature	Topr	-40	-	85	°C	
4	Storage Temperature	Tstg	-55	~	125	°C	
5	Supply Voltage	VDD	3.3±10%			V	
6	Input Current	Icc	-	-	10	mA	
7	Output State Control	-	Enable/disable			-	
8	Output Load: CMOS	CL	15			pF	
9	Output Voltage High	VoH	90% Vdd	-	-	V	
10	Output Voltage Low	Vol	-	-	10% Vdd	V	
11	Rise Time	Tr	-	-	5	ns	10%-90% VDD Level
12	Fall Time	Tf	-	-	5	ns	90%-10% VDD Level
13	Symmetry (Duty ratio)	TH/T	40	50	60	%	
14	Start-up Time	Tosc	-	-	3	ms	
15	Standby current			-	10	μA	
16	Phase Jitter(rms)		-	-	1	ps	12kHz to 20MHz
17	Aging	-	±3			$\times 10^{-6}$ /yr.	1st. Year at 25°C
18	Oscillation mode		Fundamental				



## 2、Mechanical Structure(mm)

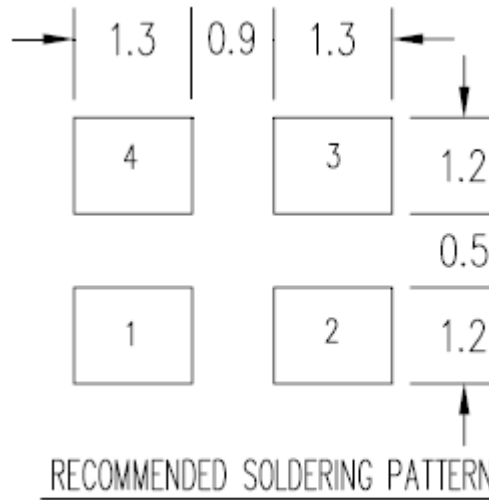
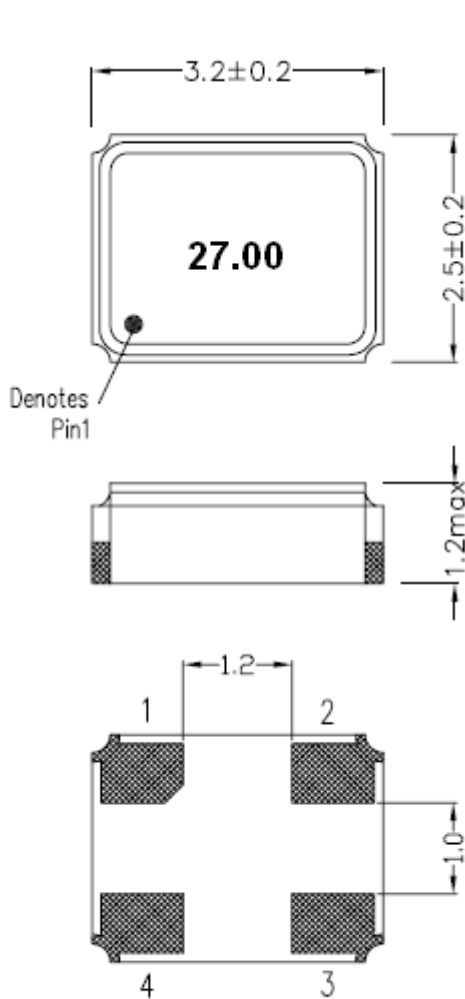

### PIN CONNECTION

P/N	FUNCTION
1	Enable/Disable*
2	GND
3	Output
4	VDD

\* Enable/Disable functional description  
 When pin1 goes high ( $\geq 0.7V_{DD}$ ) or open, the Oscillator in normal operation and has output in frequency. When pin1 goes low ( $\leq 0.3V_{DD}$ ), the oscillator stops and the oscillator output (Pin3) becomes high impedance.

Note1: Tolerance  $\pm 0.2\text{mm}$

## 3、Test Circuit and Wave Form

### CMOS TEST CIRCUIT

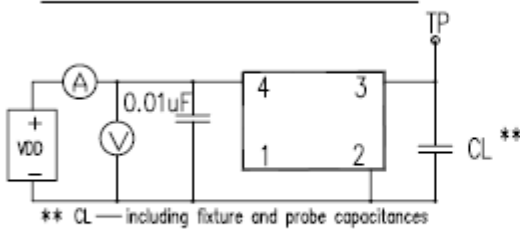

### TYPICAL CMOS WAVE FORM

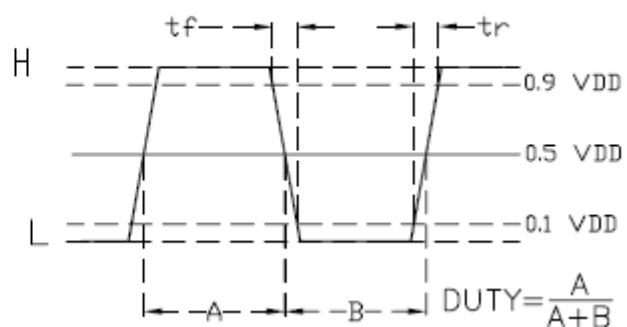



## 4、 Reliability Specifications

NO.	ITEM	SPECIFICATION	TEST METHOD
4.1	Temperature Cycle (GB/T 2423.22-2002, Method Nb)	Frequency change after test $\leq\pm$ 5ppm.	10 cycles from -55°C to 125°C. Measurement taken after DUT being left at room temperature for 24 $\pm$ 2 hours.
4.2	Low Temperature Storage (GB/T 2423.1-2001, Method Aa)	Frequency change after test $\leq\pm$ 5ppm.	Spending 72 hrs at -55°C $\pm$ 3°C constant temperature. Measurement taken after DUT being left at room temperature for 24 $\pm$ 2 hours.
4.3	High Temperature Storage (GB/T 2423.2-2001, Method Ba)	Frequency change after test $\leq\pm$ 5ppm.	Spending 72 hrs at 125°C $\pm$ 3°C constant temperature. Measurement taken after DUT being left at room temperature for 24 $\pm$ 2 hours.
4.4	Humidity (GB/T 2423.3-2006, Method Cab)	Frequency change after test $\leq\pm$ 5ppm.	Spending 96 hrs at 40 °C $\pm$ 3 °C, with 90 $\pm$ 3% R.H. Measurement taken after DUT being left at room temperature for 24 $\pm$ 2 hours.
4.5	Vibration (GB/T 2423.10-1995, Method Fc)	Frequency change after test $\leq\pm$ 5ppm.	Apply 0.75mm vibration at sweep frequency 10~500 Hz, for 2h. 10 cycles in each direction of 3 axis. Measurement taken after 1 hour.
4.6	Shock (GB/T 2423.5-1995, Method Ea)	Frequency change after test $\leq\pm$ 5ppm. No visible damages.	Peak 1000m/s <sup>2</sup> , normal width 6ms half sine wave form, 3.7m/s, 3 perpendicular axis of samples, 3 cycles / direction, total 18 cycles. Measurement taken after 1 hour.
4.7	Drop (GB/T 2423.8-1995, Method Ed)	Frequency change after test $\leq\pm$ 5ppm. No visible damages.	Free drop to the wooden plate from 1.0 m heights for 3 times.
4.8	Solderability (GB/T 2423.28-2005, Method Tc)	Terminals shall be covered more then 95% with solder.	In 245 $\pm$ 5°C solder bath for 2 $\pm$ 0.5 seconds. There is no need to do functioned test. 8-12X magnifier.
4.9	Terminal Strength (JIS-C-6429 Method 1 & 2 )	No visible damage	Mount on a glass-epoxy board (100x50x1.6mm), then bend to 2mm displacement (velocity 1mm/sec) and keep for 5 seconds. or pulling force 0.5 kg for at least 60 seconds.
4.10	Resistance to Soldering Heat (GB/T 2423.28-2005, Test Tb Method 1B)	Frequency change after test $\leq\pm$ 5ppm.	Passed through the re-flow oven under the following condition. Preheat to 150°C $\pm$ 5°C for 60 to 120sec, and peak 265°C $\pm$ 5°C for 10s $\pm$ 3sec. Measurement taken after DUT being left at room temperature for at 24 $\pm$ 2 hours.



## 5、 Recommended Reflow soldering condition (SMD)

### ■ Solder profile

Peak:  $245\pm 5^{\circ}\text{C}$  Soldering zone:  $230^{\circ}\text{C}$  or more,  $30\pm 10\text{s}$ .

Pre-heating zone 1:  $150\sim 180^{\circ}\text{C}$ ,  $90\pm 30\text{s}$

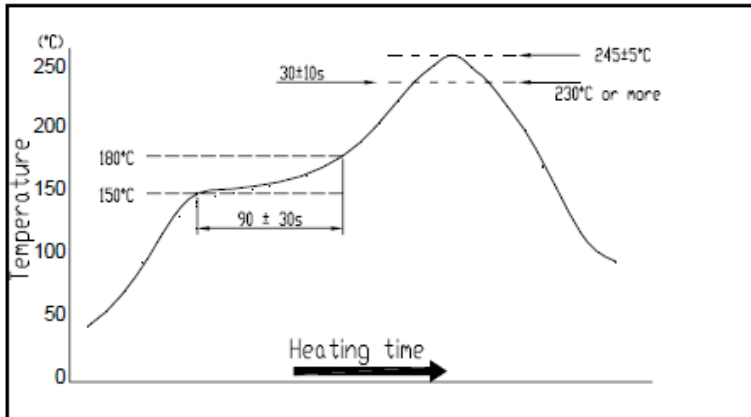

Temperature profile for reflow soldering

## 6、 Package: Tape & Reel (mm)

