

Customer Code : _____

DATASHEET

DAPU P/N: **DPBF3000001**

Plot			The Label
Drew	Audited	Approved	Stamp, please! Thanks!
Date: 2017.03.17			

Guangdong Dapu Telecom Technology Co.,Ltd

Bldg16,.N.Ind.Zone,SSL Industry Park, Dongguan City, Guangdong Province, China

TEL: 0086-0769-88010888 FAX: 0086-0769-81800098



1、Electrical Parameters

MODEL: DPBF30000001							
No.	Parameters	SYM.	Electrical Spec.				Notes
			Min.	Typ.	Max.	Units	
1	Nominal Frequency	FL	300.00			MHz	
2	Output Waveform		LVDS				
3	Vdd		-0.5		4	V	
4	Supply Voltage		2.97	3.3	3.63	V	
5	Frequency Stability	F-stab	-25		+25	$\times 10^{-6}$	Inclusive of Initial tolerance at 25 °C, 1st year aging at 25 °C, and variations over operating temperature, rated power supply voltage and load.
6	Operating Temperature	T-opr	-40	~	+85	°C	
7	Storage Temperature	T-stg	-65	~	+150	°C	
8	Current Consumption	Icc	-	47	55	mA	
9	OE Disable Supply Current	I_OD			35	mA	
10	Standby Current	I_std			100	μ A	
11	Rise/Full Time	Tr、 Tf		495	600	ps	20%~80%
12	Duty Cycle	DC	45		55	%	
13	Differential Output Voltage	VOD	250	350	450	mV	
14	Output Disable Leakage Current		-		1	μ A	OE=Low
15	Input Voltage High	VIH	70%	-	-	Vdd	Pin 1 , OE
16	Input Voltage Low	VIL	-	-	30%	Vdd	Pin 1 , OE
17	Input Pull-up Impedence	Z_in		100	250	K Ω	Pin 1, OE logic high or logic low, or ST logic high
18	Start up Time	T_start	-	6	10	ms	Measured from the time Vdd reaches its rated minimum value
19	OE Enable/Disable Time	T_oe	-	-	115	ns	
20	Resume Time	T_resume		6	10	ms	
21	RMS Period Jitter	T_jitt	-	1.4	1.7	ps	
22	VOD Magnitude Change				50	mV	
23	Offset Voltage	VOS	1.125	1.2	1.375	V	
24	VOS Magnitude Change				50	mV	
25	Phase Jitter	T_phj	-	0.6	0.85	ps	Integration bandwidth =12 kHz~20 MHz



26	Mechanical Shock	MIL-STD-883F,Method 2002
	Mechanical Vibration	MIL-STD-883F,Method 2007
	Temperature Cycle	JESD22, Method A104
	Solderability	MIL-STD-883F,Method 2003
	Moisture Sensitivity Level	MSL1 @260°C

2、Mechanical Structure(mm)

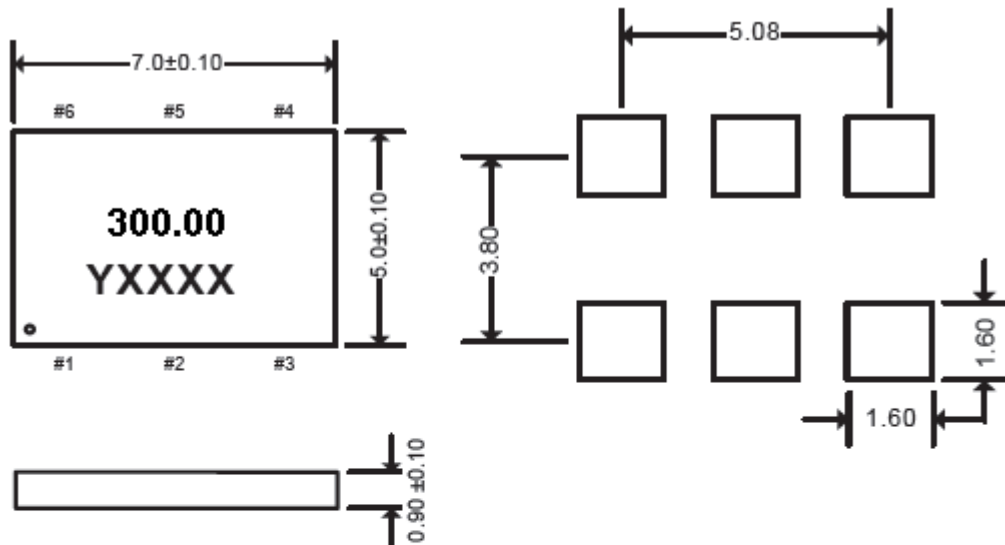

Pin	Function
#1	OE
#2	NC
#3	GND
#4	OUT+
#3	OUT-
#4	VDD

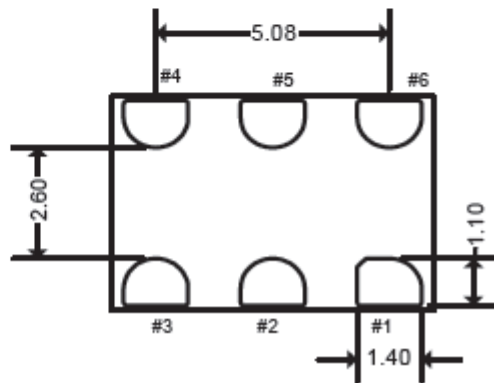

unit:mm

Note1:Tolerance ± 0.2 mm without mark

Note2: Referential weight 0.2g

Note3: Y denotes manufacturing origin and XXXX denotes manufacturing lot number. The value of “Y” will depend on the assembly location of the device

Note4: A capacitor of value 0.1 μ F or higher between Vdd and GND is required



3、 Waveform Diagrams

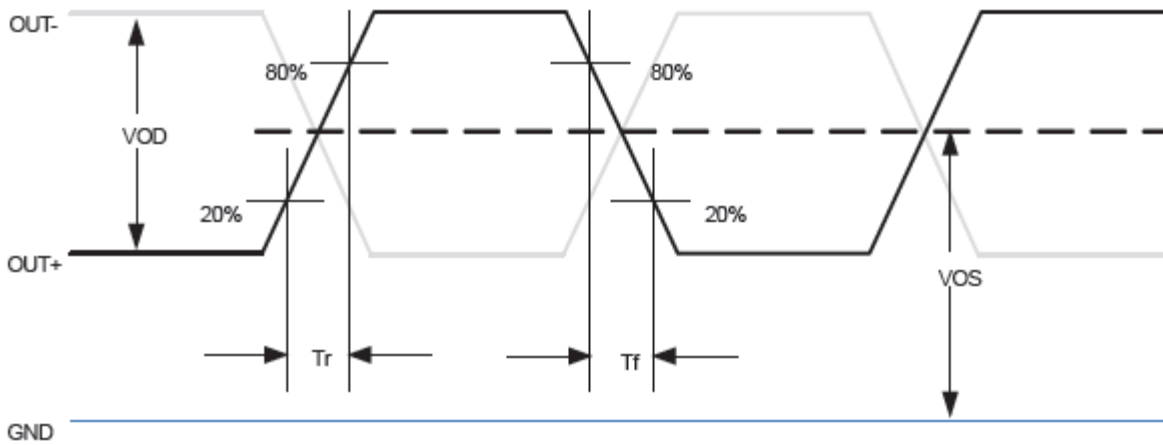

4、 Termination Diagrams

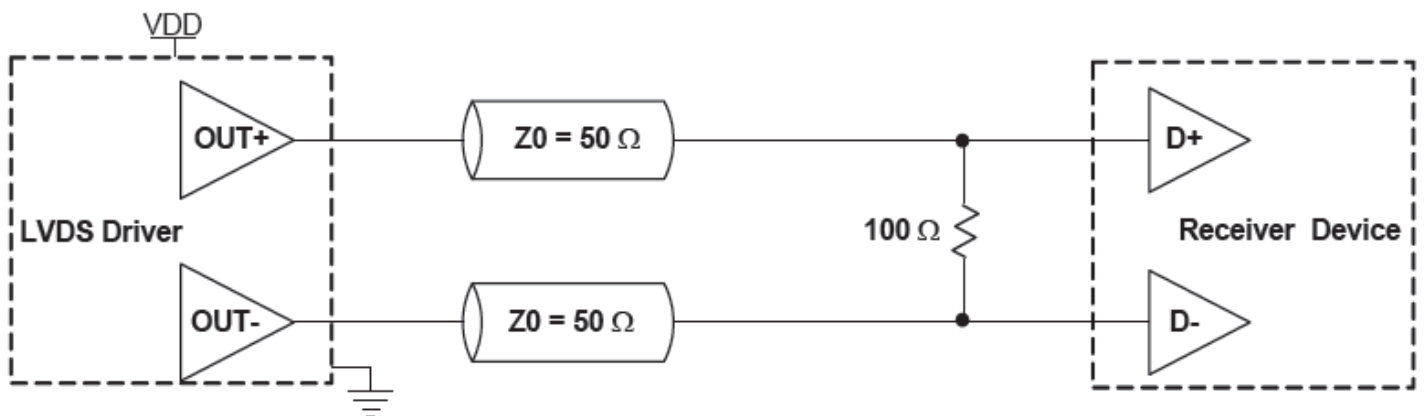

5、 Package: Tape & Reel (mm)

