

Customer Code : _____

DATASHEET

DAPU P/N: **DPBE15625001**

Plot			The Label
Drew	Audited	Approved	Stamp, please! Thanks!
Date: 2017.02.27			

Guangdong Dapu Telecom Technology Co.,Ltd

Bldg16,.N.Ind.Zone,SSL Industry Park, Dongguan City, Guangdong Province, China

TEL: 0086-0769-88010888 FAX: 0086-0769-81800098



1、Electrical Parameters

MODEL: DPBE15625001							
No.	Parameters	SYM.	Electrical Spec.				Notes
			Min.	Typ.	Max.	Units	
1	Nominal Frequency	FL	156.25			MHz	
2	Output Waveform		LVDS				
3	Vdd		-0.5		4	V	
4	Supply Voltage		2.97	3.3	3.63	V	
5	Frequency Stability	F-stab	-25		+25	$\times 10^{-6}$	Inclusive of initial tolerance, operating temperature, rated power supply voltage, and load variations.
6	Operating Temperature	T-opr	-40	~	+85	°C	
7	Storage Temperature	T-stg	-65	~	+150	°C	
8	Current Consumption	Idd	-	47	55	mA	
9	OE Disable Supply Current	I_OE			35	mA	OE=Low
10	Differential Output Voltage	VOD	250	350	450	mV	
11	Output Disable Leakage Current				1	μ A	OE=Low
12	Standby Current	I_std			100	μ A	
13	Rise/Full Time	Tr、Tf		495	700	ps	20%~80%
14	Duty Cycle	DC	45		55	%	
15	VOD Magnitude Change			-	50	mV	
16	Offset Voltage	VOS	1.125	1.2	1.375	V	
17	VOS Magnitude Change				50	mV	
18	Input Voltage High	VIH	70%	-	-	Vdd	Pin 1
19	Input Voltage Low	VIL	-	-	30%	Vdd	Pin 1
20	Input Pull-up Impedence	Z_in	2			M	Pin 1, ST logic low
21	Start up Time	T_start	-	6	10	ms	Measured from the time Vdd reaches its rated minimum value
22	First Year aging	F_aging1	-2		+2	$\times 10^{-6}$	@25°C
23	10-Year aging	F_aging10	-5		+5	$\times 10^{-6}$	@25°C
24	OE Enable/Disable Time	T_oe	-	-	115	ns	
25	Resume Time	T_resume		6	10	ms	
26	RMS Period Jitter	T_jitt	-	1.2	1.7	ps	f = 156.25 MHz, VDD = 3.3V
27	Phase Period Jitter(Random)	T_phj	-	0.6	0.85	ps	f = 156.25 MHz, Integration bandwidth = 12 kHz to 20 MHz, all Vdds



28	Mechanical Shock	MIL-STD-883F,Method 2002
	Mechanical Vibration	MIL-STD-883F,Method 2007
	Temperature Cycle	JESD22, Method A104
	Solderability	MIL-STD-883F,Method 2003
	Moisture Sensitivity Level	MSL1@260°C

2、Mechanical Structure(mm)

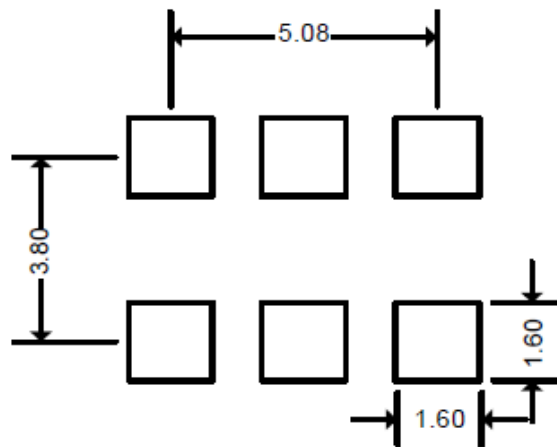
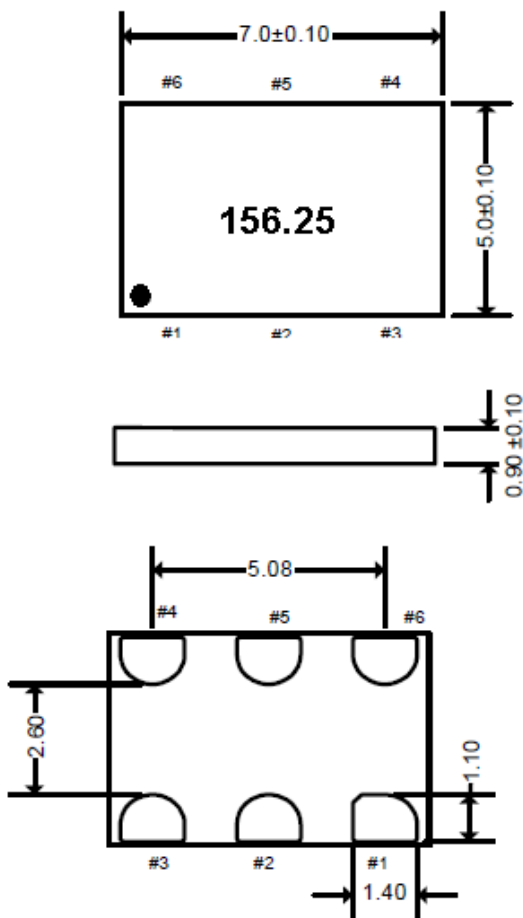

Pin	Function
1	\overline{ST}
2	NC
3	GND
4	OUT+
5	OUT-
6	VDD

unit:mm

Note1:Tolerance ± 0.2 mm without mark

Note2: Referential weight 0.2g



3、Waveform Diagrams

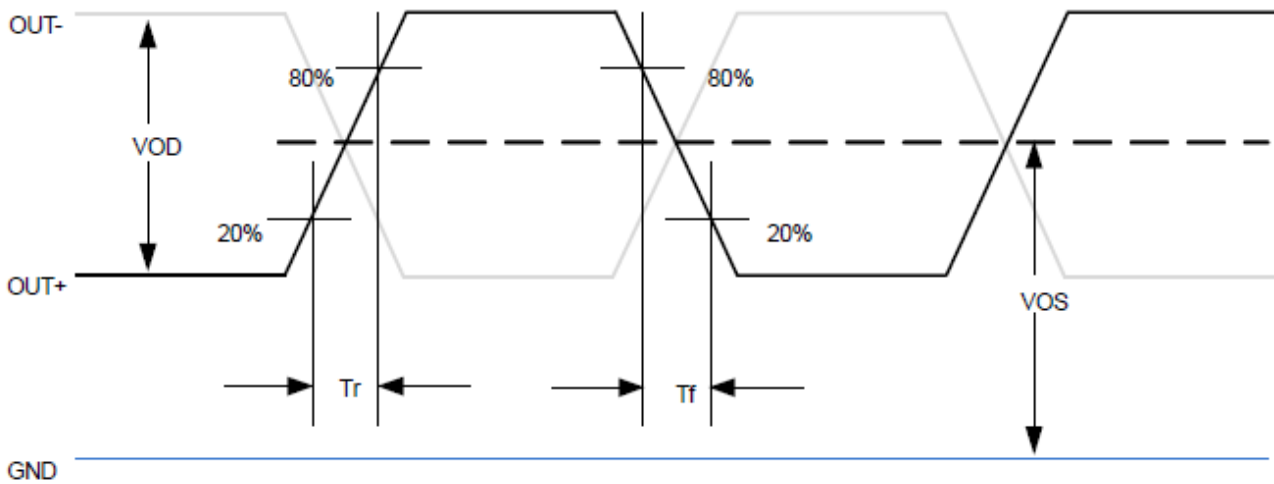

4、Termination Diagrams

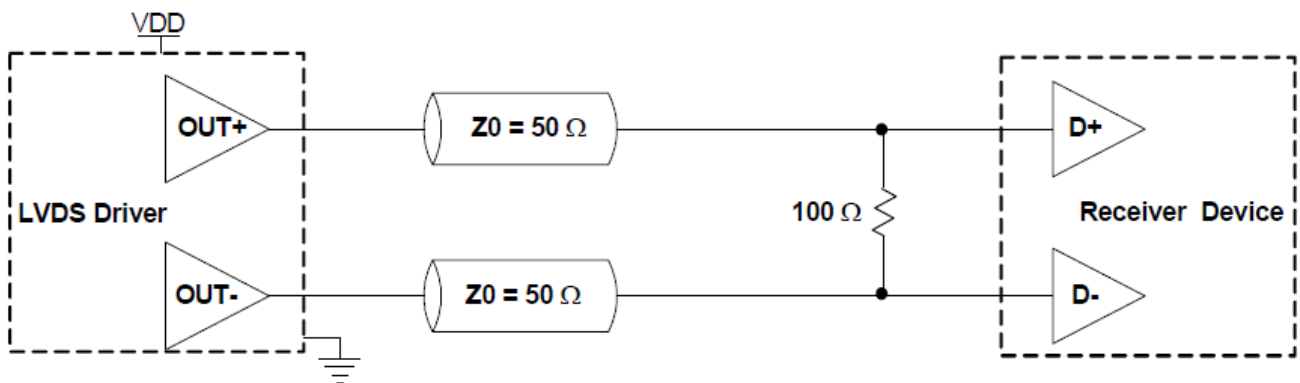

5、Package: Tape & Reel (mm)

