

Travelling Merchant: _____

DATASHEET

Standard: **V331-P326-16.384MHz**

P/N: _____

Plot			The Label
Drew	Audited	Approved	Stamp, please! Thanks!
Date: 2016.11.10			

Guangdong Dapu Telecom Technology Co.,Ltd

Bldg13-16,.N.Ind.Zone,SSL Industry Park, Dongguan City, Guangdong Province, China

TEL: 0086-0769-88010888 FAX: 0086-0769-81800098



1、 Electrical Parameters

Parameters	SYM	Electrical Spec.				Notes
		Min.	Typ.	Max.	Units	
Frequency Stabilities						
Nominal Frequency	F_N	16.384			MHz	
Vs. operating temperature rang	F_{STAB}	0		+70	$\times 10^{-6}$	Ref. +25°C
Vs.OTR		-15		+15	$\times 10^{-6}$	
Accuracy		-10		+10	$\times 10^{-6}$	@25°C
Vs. aging /1.year		-3		+3	$\times 10^{-6}$	@25°C, $V_C=2.5V$, $V_{CC}=5.0V$, Load=15 pF
RF Output						
Output Waveform		HCMOS				
Load	I_{OUT}	15			pF	
Output Voltage High	V_{OH}	4.5			V	
Output Voltage Low	V_{OL}			0.4	V	
Rise / Fall Time	T_r / T_f			5	ns	20%-80%
Duty Cycle		40	~	60	%	@50%
Supply Voltage						
Supply Voltage	V_{CC}	4.75	5.0	5.25	V	
Input Current	I_{CC}			15	mA	
Control Voltage						
Control Voltage Rang	V_C	0		5.0	V	$V_C=2.5V$
Frequency Tuning Range	PR	± 100	~		$\times 10^{-6}$	
Linearity	Lin			20	%	
Slope		Positive				
Input Impedance	Z_{IN}	100			MΩ	
Environmental Conditions						
Operating Temperature	T_{OP}	0	~	70	°C	
Storage Temperature	T_{ST}	-40	~	85	°C	
ESD Level	Human Body Model, class2: 2000V to 4000V; ANSI/ESDA/JEDEC JS-001-2010.					
	Machine Model, class B: 200V to 400V; ANSI/ESDA/JEDEC JS-001-2010.					
Vibration	Test Condition: 0.75mm; acceleration:10g;10Hz~2000Hz, one cycle per 30 min, test 2 hour. (3 times for each 3 directions X , Y , Z) .IEC 68-2-06 Test Fc.					
Shock	100g; 6ms; half sine wave (3 times for each 3 directions X , Y , Z) ,IEC 68-2-27 Test Ea/Severity 50A.					



2、 Mechanical Structure(mm)

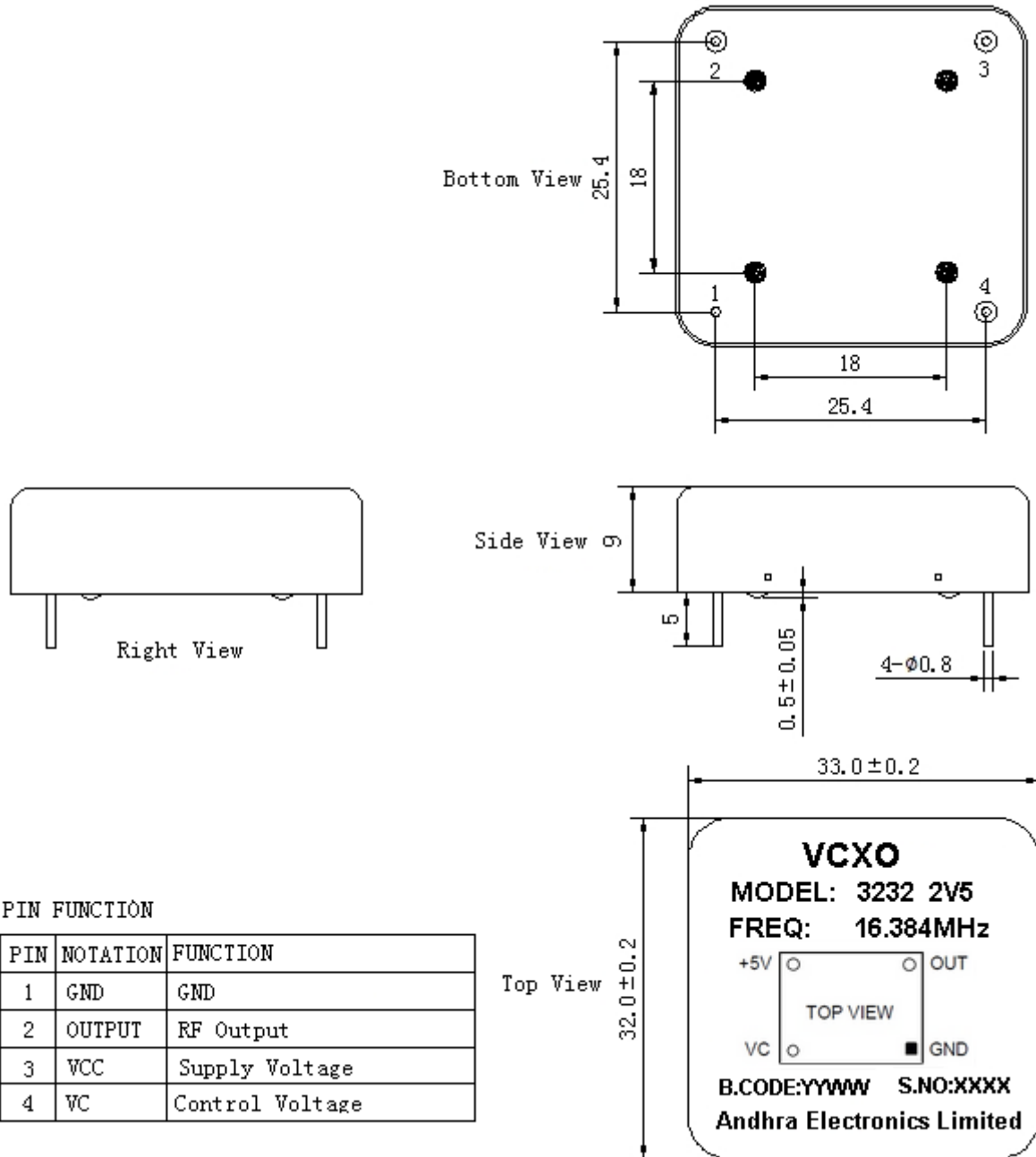

- Note1:** Tolerance ±0.2mm without mark
- Note2:** The first two YY representative: year
After two WW representative: week
- Note3:** The XXXX representative: serial number



3、 Test circuit

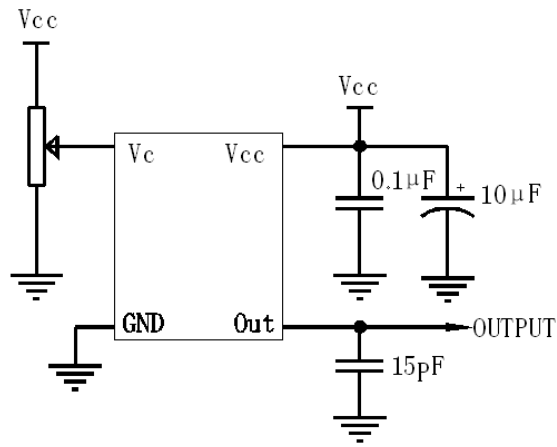

4、 Reflow Soldering Curve (RoHS)

