

Travelling Merchant: _____

DATASHEET

Standard: DP9H03200001

Plot			The Label
Drew	Audited	Approved	Stamp, please! Thanks!
Date:			

Guangdong Dapu Telecom Technology Co.,Ltd

Bldg13,.N.Ind.Zone,SSL Industry Park, Dongguan City, Guangdong Province, China

TEL: 0086-0769-88010888 FAX: 0086-0769-81800098



1、Electrical Parameters

MODEL: DP9H03200001							
No.	Parameters	SYM.	Electrical Spec.				Notes
			Min.	Typ.	Max.	Units	
1	Nominal Frequency	FL	32.768			KHz	
2	Frequency Tolerance	-	-20		+20	ppm	at 25°C±3°C
3	Shunt Capacitance	C0	-	0.8	-	pF	
4	Motional Capacitance	C1	-	1.9	-	fF	
5	Insulation Resistance	-	500	-	-	MΩ	at DC 100V±15V
6	Operating Temperature Range	-	-40	~	+85	°C	
7	Aging	-	-3		+3	ppm	1st Year
8	Drive Level	DL	-	-	1	uW	
9	Series Resistance	-	-	-	65	KΩ	
10	Peak Temperature (Frequency)		25°C±5°C				
11	Frequency-Temperature Coefficient	-	-	-	$-4 \times 10^{-8} / ^\circ\text{C}^2$		
12	Load Capacitance	CL	12.5			pF	
13	Storage Temperature Range	-	-55	~	+125	°C	
14	Product Type	SMD Ceramic surface x'tal 6.9*1.4					
15	Heat Shock	-40 °C~85 °C, Dwell:30 min, 20 Cycles					MIL-STD-883E
16	Vibration Test	Freq. 10~60Hz, Amplitude 1.5mm, 3 Direction each 2hours.					MIL-STD-883E
17	Mechanical Shock Test	75 cm Height, 3 times wooden board					



2、Mechanical Structure(mm)

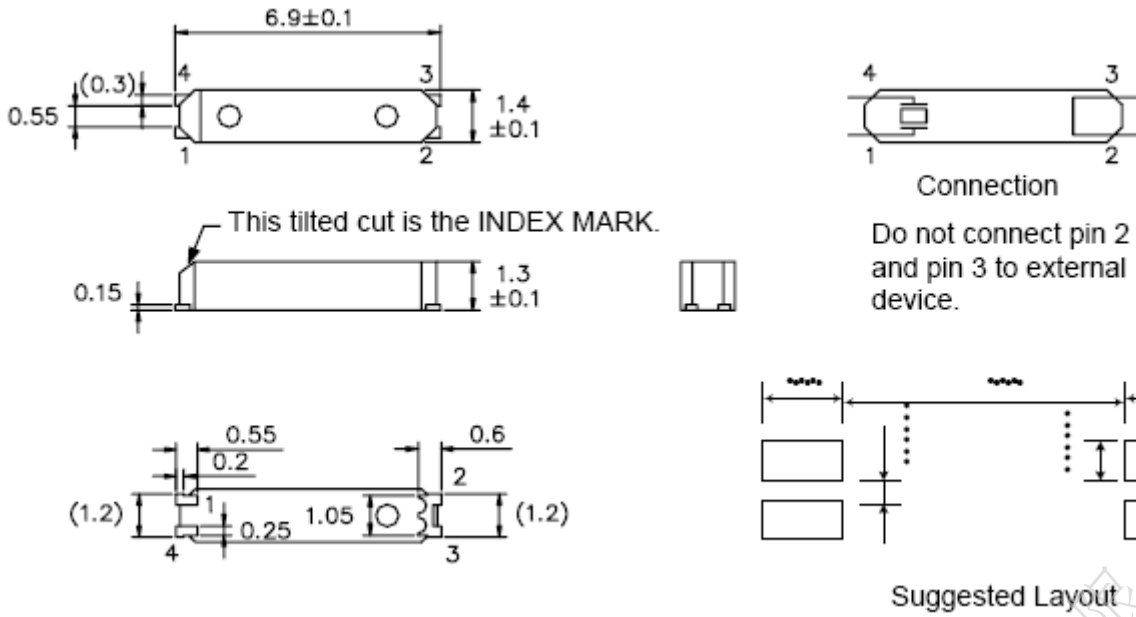

3、Reflow Soldering Curve (RoHS)

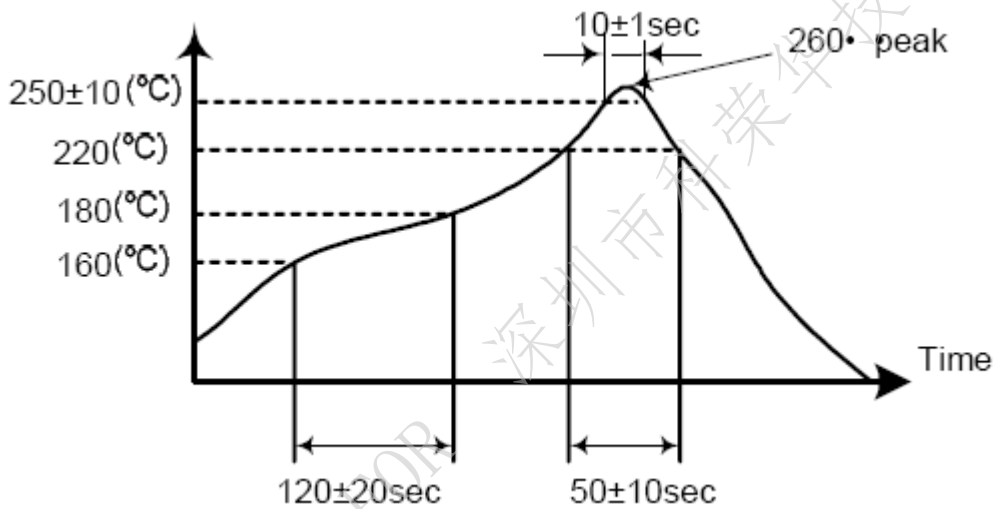



4、 Package: Tape & Reel (mm)

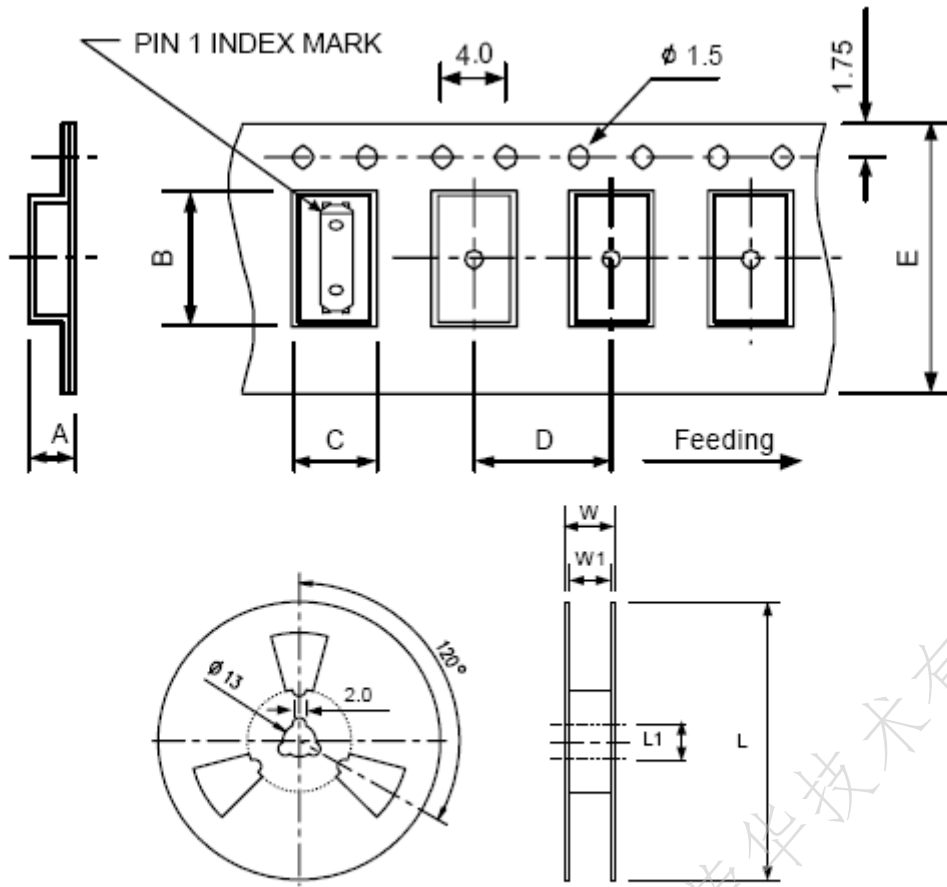

DIMENSIONS	A	B	C	D	E	L	L1	W	W1	pcs / Reel
	1.6	7.3	1.6	8	16	330	13	24.3	17.3	3K