

Travelling Merchant: \_\_\_\_\_

# DATASHEET

Standard:     **V936-B611-122.88MHz**    

Plot			The Label
Drawing	Auditing	Approve	Stamp, please! Thanks!
Date: 2009-09-30			

**Dongguan Dapu Telecom Technology Co.,Ltd**

No.1 New City Street,Songshan Lake Science Park, Dongguan City,Guangdong province, PRC China

TEL: 0086-0769-88010888 FAX: 0086-0769-81800098



## The parameter of product

### MODEL: V936-B611-122.88MHz

#### 1. Output

1.1. Frequency	122.88MHz
1.2. Waveform	LVPECL
1.3. Symmetry	45%~55%
1.4. Rise / Fall time (20%~80%)	1ns max.
1.5. Load	50 Ω to +1.3VDC

#### 2. Frequency Stability

2.1. Tolerance vs. Temperature Rang	$\leq \pm 3.0 \times 10^{-5}$	@-40°C ~ +85°C ,ref. to 25 °C
2.2. frequency Tolerance	$\leq \pm 1.5 \times 10^{-5}$	@25 °C VC=1.65V
2.3. Tolerance vs. Supply Voltage	$\leq \pm 5.0 \times 10^{-6}$	@3.3VDC±5%
2.4. Tolerance vs. Load	$\leq \pm 1.0 \times 10^{-6}$	@ Load±10%
2.5. Aging	$\leq \pm 3.0 \times 10^{-6}$ / year	

#### 3. Voltage

3.1. Supply Voltage	+3.3VDC±5%
---------------------	------------

#### 4. Current

4.1. Supply current	70mA (Typical)
---------------------	----------------

#### 5. Electrical frequency adjustment

5.1. Control Voltage = 0 V	-60ppm~-150ppm
5.2. Control Voltage = 1.65 V	-15ppm~+15ppm
5.3. Control Voltage = 3.3 V	+60ppm~+150ppm
5.4. Linearity	$\leq \pm 20\%$
5.5. Input impedance	$\geq 1M \Omega$
5.6. Slope	Positive

#### 6. Phase noise(Typical)

6.1. 10Hz	-65dBc/Hz
6.2. 100Hz	-90dBc/Hz
6.3. 1 KHz	-120dBc/Hz
6.4. 10KHz	-138dBc/Hz
6.5. 100KHz	-140dBc/Hz

#### 7. Temperature

7.1. Operable temperature range	-40°C to +85°C
7.2. Storage temperature range	-55°C to +125°C



8. Mechanical

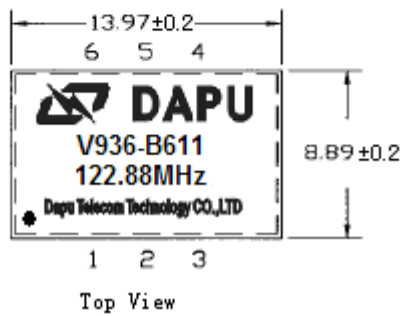
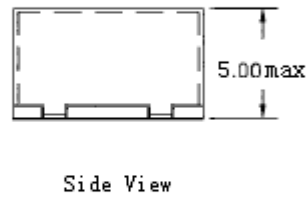
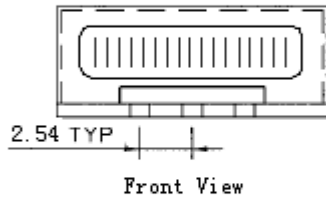
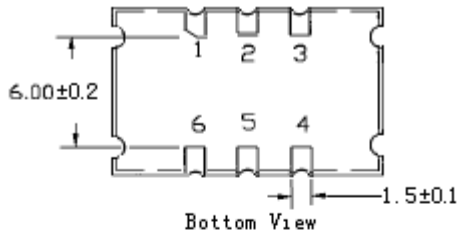

PIN FUNCTION

1	VOLTAGE CONTROL
2	E/D
3	GND
4	OUTPUT
5	$\overline{\text{OUTPUT}}$
6	V <sub>CC</sub>

Note: Enable/ Disable

Unit : mm

Input Level:  $V_{ih} \geq V_{CC} - 1.025V$

$V_{il} \leq V_{CC} - 1.62V$

E/D	OUT1	OUT2
Low Level, Open	Data	Data
High Level	Logic low	Logic high



9. Suggested output load configuration

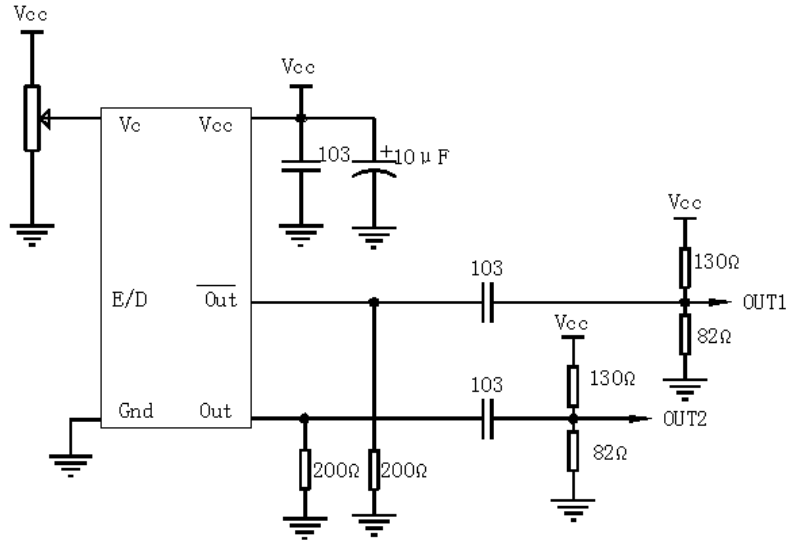

10. Recommended Reflow Profile (RoHS)

