

Customer Code : \_\_\_\_\_

# DATASHEET

DAPU P/N: CM22B-J328-10.00MHz-A

Customer P/N: \_\_\_\_\_

DAPU			Customer Approval
Drew	Audited	Approved	Stamp, please! Thanks!
Date: 2015.05.26			

## Guangdong Dapu Telecom Technology Co.,Ltd

Bldg13-16,.N.Ind.Zone,SSL Industry Park, Dongguan City, Guangdong Province, China

TEL: 0086-0769-88010888 FAX: 0086-0769-81800098





## 1. Electrical Parameters

	Parameters	Min.	Typ.	Max.	Unit.	Test Condition
1 PPS Reference Input	Waveform	HCMOS				
	High-Level Output Voltage ( $V_{IH}$ )	2.4		3.4	V	50 $\Omega$
	Low-Level Output Voltage ( $V_{IL}$ )			0.4	V	
	Pulse Width	10			$\mu$ s	
	Connector	Pin 4				
State Input	Parameters	Min.	Typ.	Max.	Unit.	Test Condition
	Lock	2.4		3.4	V	<5mA Load
	Holdover			0.4	V	<5mA Load
	Connector	Pin 1				
RF Output	Parameters	Min.	Typ.	Max.	Unit.	Test Condition
	Nominal Frequency	10.00			MHz	Synchronization with input 1PPS
	Waveform	HCMOS				
	High-level Output Voltage ( $V_{OH}$ )	2.7			V	< 5mA Load
	Low-level Output Voltage ( $V_{OL}$ )			0.4	V	< 5mA Load
	Rise/Fall Time			8	ns	Load 15pF
	Duty Cycle	45	50	55	%	Load 15pF
	Frequency Tolerance vs. Operating Temperature Range	-0.01		+0.01	$\times 10^{-6}$	$T_A$ varied from -40 $^{\circ}$ C to 85 $^{\circ}$ C, measurement referenced to frequency observed with $f_{ref}=(f_{max}+f_{min})/2$ , $V_{cc}=3.3V$ , $O_{load}=15pF$ , temperature variable speed less than 2 $^{\circ}$ C per minute.
	Accuracy	-0.01		+0.01	$\times 10^{-9}$	24 hours average when locked to 1PPS after power on 2days.
	Short-term Stability	-0.1		+0.1	$\times 10^{-9}$	Temperature stability, no EMI/EMC or other interference, test after power for 1 hour ref. to 25 $^{\circ}$ C; 1s, using PN9000 equipment.
Warm-Up	-1		+1	$\times 10^{-6}$	$T_A=25^{\circ}$ C, $V_{cc}=3.3V$ constant measurement referenced to 10.00MHz, after power on 3min with GPS lock.	



	Aging Tolerance Per Day	-5		+5	$\times 10^{-9}$	Constant measurement referenced to frequency observed with $T_A=25^\circ\text{C}$ , $V_{CC}=3.3\text{V}$ , after 30days of operation.	
	Aging Tolerance 1 Year	-0.5		+0.5	$\times 10^{-6}$		
	Phase Noise (All conditions)			-100	-90	dBc/Hz	10Hz
				-130	-120		100Hz
				-148	-143		1KHz
				-150	-145		10KHz
				-150	-145		100KHz
		-150	-145	1MHz			
Connector	Pin8						
Holdover Capability	Holdover Time	Min.	Typ.	Max.	Unit.	Test Condition	
	24 Hours	-80		+80	$\mu\text{s}$	$\Delta T=\pm 2^\circ\text{C}$ , 24 hours holdover after turn on 3 days and lock 2 day. Temperature variable speed less than $1^\circ\text{C}$ per minute.	
Supply Voltage	Parameters	Min.	Typ.	Max.	Unit.	Test Condition	
	Supply Voltage	3.13	3.3	3.47	V		
	Warm up current			500	mA		
	Steady Consumption			250	mA	@ $25^\circ\text{C}$	
	AC Ripple			50	mVpk-pk	10Hz to 1MHz	
	Connector	Pin 2					
1 PPS Output	Parameters	Min.	Typ.	Max.	Unit.	Test Condition	
	Waveform	HCMOS					
	High-Level Output Voltage( $V_{OH}$ )	2.4			V	50 $\Omega$	
	Low-level Output voltage ( $V_{OL}$ )			0.4	V		
	Pulse Width	10			$\mu\text{s}$		
	Phase accuracy		-50		50	ns	Power on, the 1 PPS output is the reference 1PPS in;
			-300		300	ns	When the CM is locked and stable, the 1PPS output is the divided OCXO frequency output.
Connector	Pin 7						



	Parameters	Min.	Typ.	Max.	Unit.	Test Condition
Serial Interfaces	Rx high-level Input Voltage (VH )	2.4		3.4	V	
	Rx low-level Input Voltage (VL)			0.4	V	
	Tx high-level Output Voltage (VH )	2.4		3.4	V	
	Tx low-level Output Voltage (VL)			0.4	V	
	Serial Protocol	9600-N-8-1				
	Connector	Pin5 / Pin6				
Environmental Conditions	Parameter	Conditions				
	Operating Temperature	-40℃ to 85℃				
	Storage Temperature	-55℃ to 105℃				
	Storage Humidity	30%~80%				
	ESD Level	Human Body Model,class2: 2000V to 4000V; ANSI/ESDA/JEDEC JS-001-2010.				
		Machine Model, class B: 200V to 400V; ANSI/ESDA/JEDEC JS-001-2010.				
	Moisture Sensitivity Level	Not humidity sensitive.				
	Vibration	Test Condition: 0.75mm ;acceleration:10g;10Hz~500Hz, one cycle per 30 min, test 2 hours. (3 times for each 3 directions X ,Y , Z), IEC 68-2-06 Test Fc.				
Shock	50g; 11ms; half sine wave (3 times for each 3 directions X ,Y , Z ),IEC 68-2-27 Test Ea/Severity 50A.					
Full Package Storage	Relative humidity (%)	20%~70%				
	Temperature (℃)	-10~35℃				

## 2. Functional Block Diagram

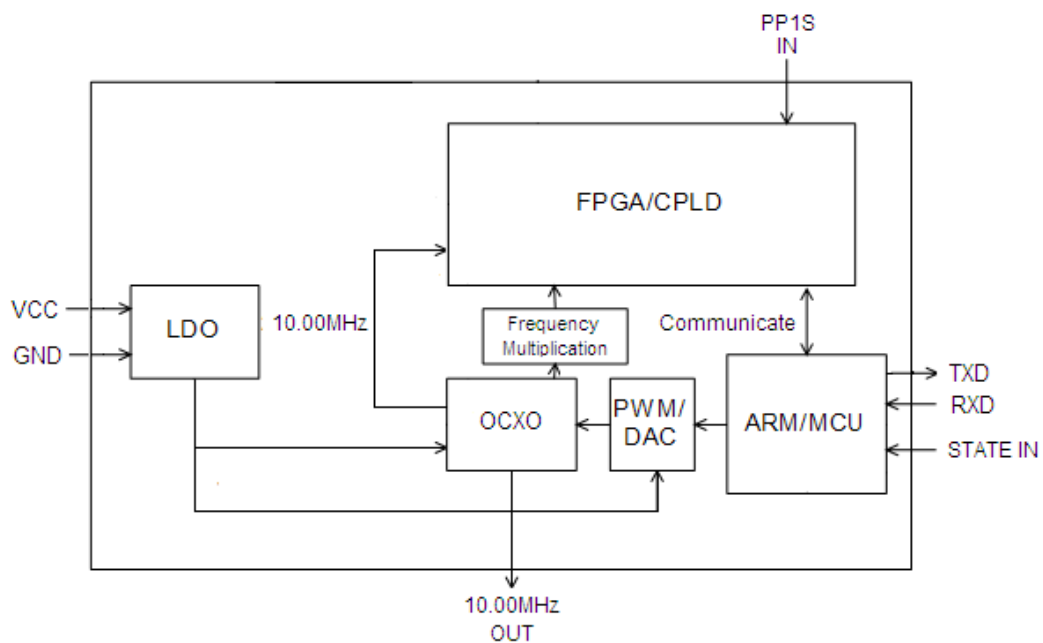



### 3. Workflow Diagram

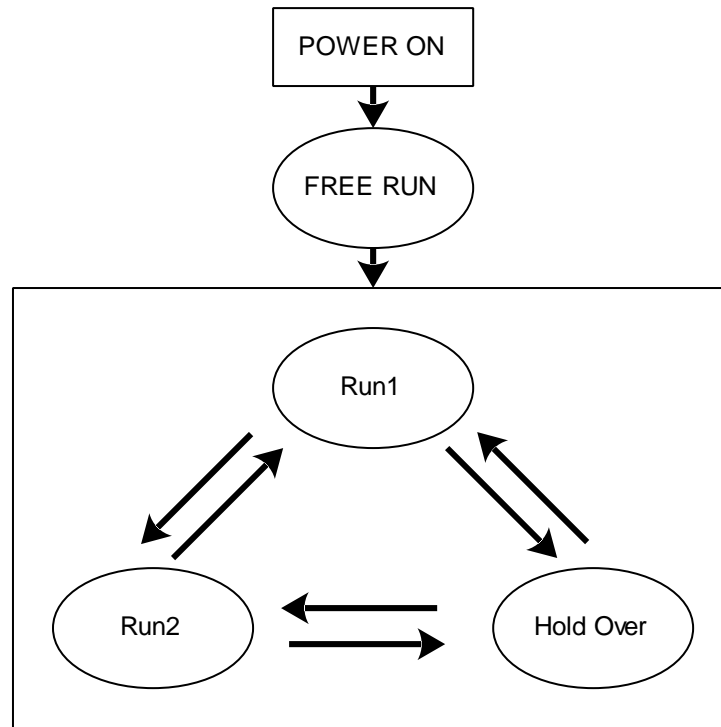

Run1: Fast track. Adjust the OCXO 10MHz output frequency quickly to track the 1PPS of 10MHz with 1PPS reference.

Run2: Slow track. Adjust the OCXO 10MHz output frequency slowly when the phase error is in the define range.

Hold Over: GPS 1PPS reference miss, an algorithm has been developed which enables adaptive modeling of the frequency stability of an OCXO with reference to a GPS timing signal.

Free Run: Clock module power on without 1PPS reference anyway.



#### 4. Mechanical Structure(mm)

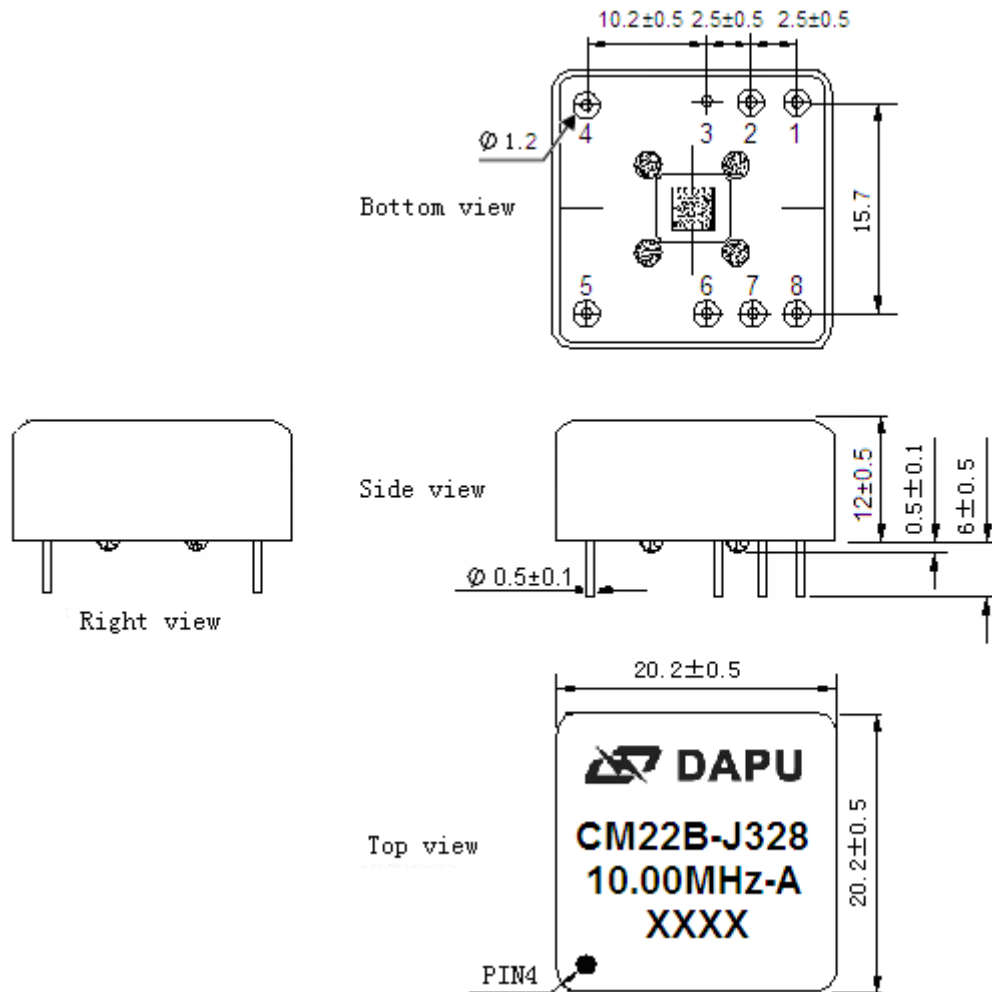

**Note1:** Tolerance  $\pm 0.20$ mm without mark

**Note2:** The first two xx representative: week  
After two xx representative: year



PIN DEFINITION			
PIN	NAME	DESCRIPTION	
1	State INPUT	H: Lock	The work state is set to normal operation when the state input is high.
		L: Holdover	The work state is set to hold over when the state input is low.
2	VCC	Power supply: 3.13V to 3.47V	
3	GND	GND	
4	PP1S Input	PP1S reference input	
5	RXD	Asynchronous serial data input. 9600-N-8-1.	
6	TXD	Asynchronous serial data output.9600-N-8-1.	
7	1PPS OUTPUT	The clock module 1PPS output .	
8	10.00MHz OUTPUT	10.00MHz OCXO frequency output, synchronization with PP1S reference.	

### 5. Typical Application

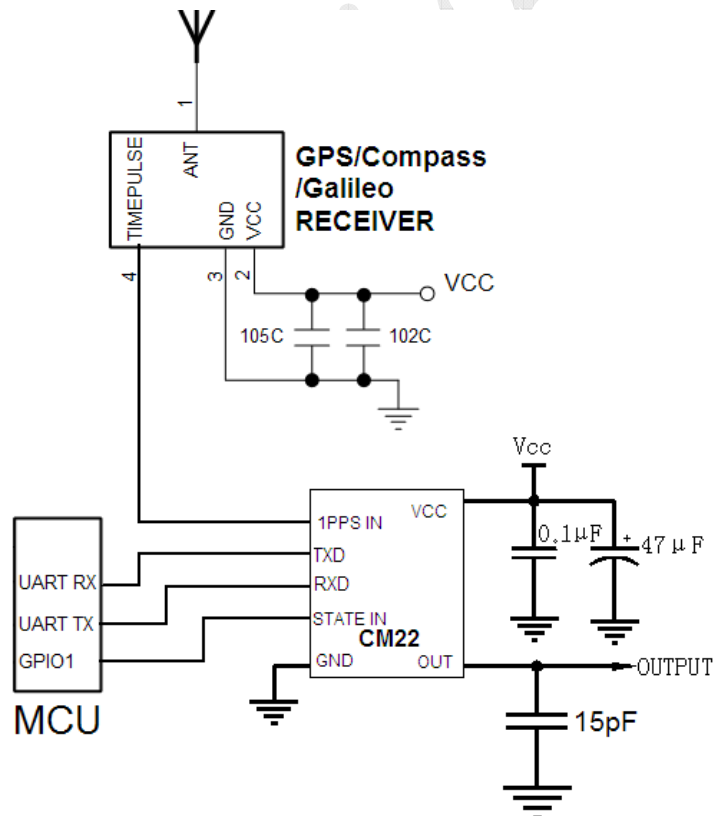

Satellite receiver offer 1PPS signal to the clock module CM22B.  
 The MCU monitor the work state of CM22B.  
 The CM22B power of 3.3V.





## 6. Reflow Soldering Curve (RoHS)

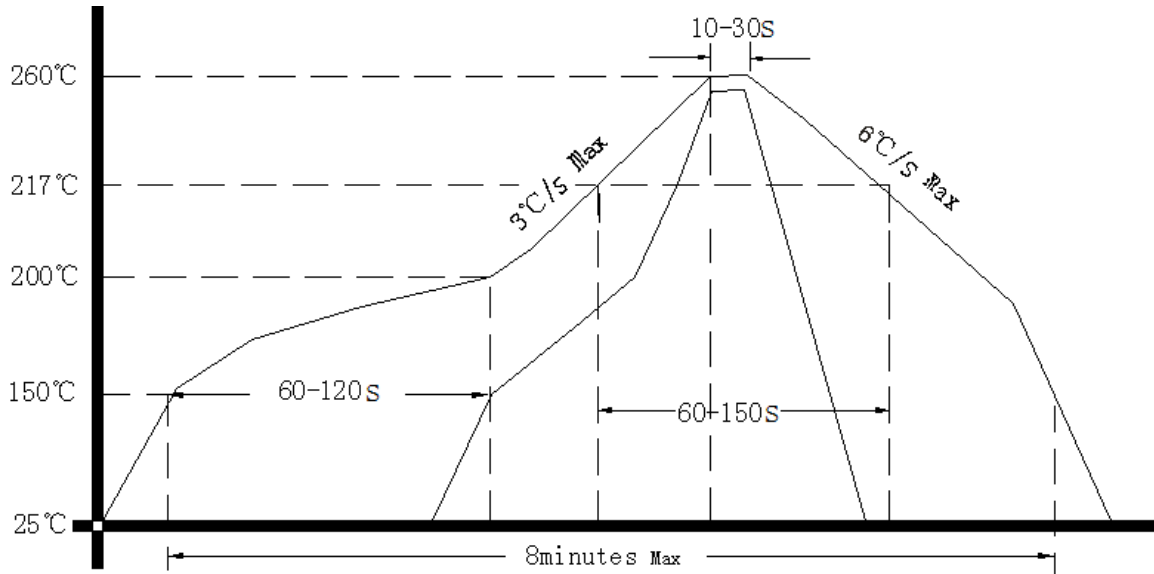

## 7. Package (mm)

