

**Table of amendment**

Version	Revision contents	Prepared by	Revised date
1.0	The first issued	<i>Amway</i>	2015.01.12
1.1	“Unit” ,“Initial Frequency Tolerance” changed	<i>Amway</i>	2015.01.14
1.2	Modified according to customer requirements: 1. “ Aging Tolerance 1 Year” added 2. “ Frequency Tolerance vs. Operating Temperature Range” , “Allan Deviation” , “Aging Tolerance Per Day” , “Current Consumption” , “ Warm-up completion time” , “ Warm up current” , “3.1.2 EEPROM for inventory and data storage” , “3.1.4 Temperature stability correction record in EEPROM” , “3. I ² C Devices Address -Notes” , “3.2. Temperature sensor” changed 3. “ Warm-up stability” ,“Frequency variation During Thermal Shock” , “Maximum daily ageing phase variation, based on mean ageing slope linear estimation over 48h” deleted	<i>Amway</i>	2015.01.28
1.3	“Initial Frequency Tolerance” and “3.2. DIGITAL THERMOMETER- Device address” changed	<i>Amway</i>	2015.01.29
1.4	1. Modified the 1 st page 2.Modified according to customer requirements: “Warm-up completion time - Test Condition” , “3.1.3 Inventory record in EEPROM -Function Code” , “3. I ² C Devices Address-Note 10-conversion formula ”changed “Internal temperature” instead of “Ambient Temperature” 3. “3.2. DIGITAL THERMOMETER- Device name” , “3. I ² C Devices Address-Note 7” corrected	<i>Amway</i>	2015.03.16
1.5	Modified according to customer requirements: Warm-up stability	<i>Amway</i>	2015.04.13



1. Electrical Parameters

MODEL: O22S-2103-10.00MHz							
Item	Description	Parameters			Unit	Test Condition	
		Min.	Typ.	Max.			
Output	Frequency	10.00			MHz		
	Output Waveform	LVTTL					
	Output Low Voltage			0.4	V	$V_{cc}=5.0V, O_{load}=15pF$	
	Output High Voltage	2.4			V	$V_{cc}=5.0V, O_{load}=15pF$	
	Duty Cycle	45	50	55	%	@50%	
	Rise / Fall Time (10%~90%)		2	3	ns	@25°C	
	Load	15			pF		
	Frequency Tolerance vs. Operating Temperature Range		-3		+3	ppb	T_A varied from -5°C to 85°C, measurement referenced to frequency observed with $f_{ref}=(f_{max}+f_{min})/2$ $V_{cc}=5.0V, O_{load}=15pF$, temperature variable speed less than 1°C per minute.
			-0.3		+0.3	ppb	$\Delta T < 5^\circ C$ within range -5°C to 85°C $V_{cc}=5.0V, O_{load}=15pF$, temperature variable speed less than 1°C per minute.
			-0.3		+0.3	ppb	Frequency variation after thermal Correction within range -5°C to 85°C $V_{cc}=5.0V, O_{load}=15pF$, temperature variable speed less than 1°C per minute.
	Initial Frequency Tolerance	-100		+100	ppb	$T_A=25^\circ C, V_{cc}=5.0V$, at shipment measurement referenced to 10MHz after 10 minutes of warm-up .	
	Warm-up stability	-15		+15	ppb	Y(unit: s) is the time needed from start up to steady status(refer to frequency test 1 hour after start-up). B(unit:°C) is ambient temperature at the moment. Formula to calculate Y at different temperature point (ambient temperature range: -7°C~85°C) is: $Y = -1.2 \times B + 235$.	
Allan Deviation			0.01	ppb	Temperature stability, no EMI\EMC or other interference, test after power for 24hours, 25°C; 1s, using PN9000 equipment.		
			0.015	ppb	Temperature stability, no EMI\EMC or other interference, test after power for 24hours, 25°C; 10s, using PN9000 equipment.		



				0.05	ppb	Temperature stability, no EMI\EMC or other interference, test after power for 24hours, 25°C; 100s, using PN9000 equipment.
	Maximum total frequency jump	-0.2		+0.2	ppb	Test the frequency every 2s after the products are powered off for 72 hours. Take 10 frequency values and calculate the average value.
	Aging Tolerance Per Day	-0.5		+0.5	ppb	V_{cc} , T_A constant measurement referenced to frequency observed with $T_A=25^\circ\text{C}$, $V_{cc}=5.0\text{V}$ and after 30 days of operation.
	Aging Tolerance 1 Year	-100		+100	ppb	
	Overall Stability	-500		+500	ppb	Inclusive of the following: operating temperature -5°C to 85°C $5.0\text{V} \pm 5\%$ 15pF load $\pm 5\%$ 10 years aging reference to nominal frequency
Power Supply	Supply Voltage	4.9	5.0	5.1	V	
	Current Consumption			800	mA	$T_A=-5^\circ\text{C}$
				300	mA	$T_A=25^\circ\text{C}$
				200	mA	$T_A=85^\circ\text{C}$
	Warm-up completion time			10	min	$T_A=25^\circ\text{C}$, Oscillator frequency within $\pm 0.015 \times 10^{-6}$, with reference to 24 hour value .
	Warm up current			800	mA	
	Ripple noise on power supply			10	mV	Peak to peak
Inrush current on the 5V supply, at power up			3500	mA	For a 50 μs max	
Phase Noise	Phase Noise @25°C			-80	dBc/Hz	1Hz
				-100		10Hz
				-120		100Hz
				-130		1KHz
				-130		10KHz
				-130		1MHz



Environmental Conditions	Reference Air Velocity	1	2	3	m/s	
	Operable Temperature	-5		+85	°C	
	Storage Temperature	-40		+85	°C	
	ESD Level	Human Body Model, class2: 2000V to 4000V; ANSI/ESDA/JEDEC JS-001-2010.				
		Machine Model, class B: 200V to 400V; ANSI/ESDA/JEDEC JS-001-2010.				
Moisture Sensitivity Level	Level 2 .					
Environmental Reliability (Operational Conditions)	Vibration(Sinusoidal)	1. Frequency range:5-9Hz (displacement: 1,2mm) 2. Frequency range:9-200Hz (displacement: 4m/s ²) 3. Duration:3×5 sweep cycles				
	Vibration(Random)	1. Frequency range:5-10Hz,10-50Hz,50-100Hz 2. ASD:0,04m ² /s ³ 3. Duration:3 × 30 minutes				
	Shocks	1. Shock spectrum: half sine 2. Duration:11ms 3. Acceleration:50m/s ² 4. Directions of bumps:6 5. Duration:100 in each direction				
	Humidity	1. Temperature:30°C 2. Humidity: 93%RH 3. Duration: 4d (96h)				
Environmental Reliability (Non Operational Conditions)	Random Vibration	1. Frequency range:5-20Hz,20-200Hz. 2. ASD:1 m ² /s ³ 3. Duration:3 × 30 minutes				
	Shocks	1. Shock spectrum: half sine 2. Duration:6ms 3. Acceleration:180m/s ² 4. Directions of bumps:6 5. Duration:100 in each direction				
	Free fall	1. Height:0.1m 2. Duration:1 fall on each face				
Environmental Reliability (Air temperature)	Low	1. low Temp:-25°C ; 2. Duration: 72h				
	High	1. low Temp:70°C ; 2. Duration: 72h				
	air/air Change	1. Temp Change:-25°C ~ 30°C 2. Cycle:5				



	Humidity	1. Temperature:30°C 2. Humidity: 93%RH 3. Duration: 4d (96h)
	Humidity (Condensation)	1. Temperature:30°C 2. Humidity: 90-100%RH 3. Duration: 2Cycle
Full Package Storage	Relative humidity (%)	20%~70%
	Temperature (°C)	-10~35°C

DAPU Confidential



2. Mechanical Structure(mm)

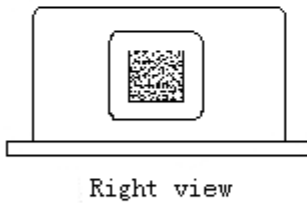
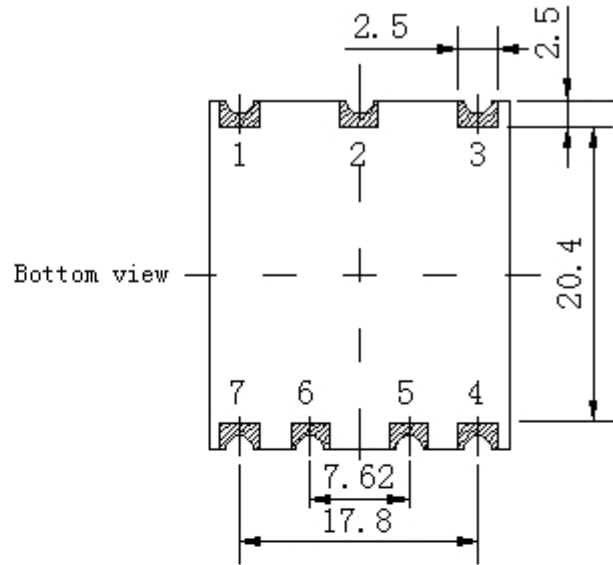
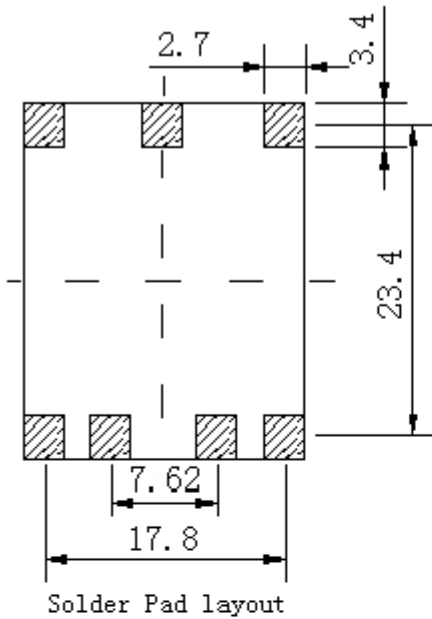

PIN FUNCTION

PIN	NOTATION	FUNCTION
1,2	NC	Not Connect
3	VCC	Supply Voltage
4	OUTPUT	RF Output
5	SCL	Serial Clock Input
6	SDA	Serial Data Input/Output
7	GND	GND

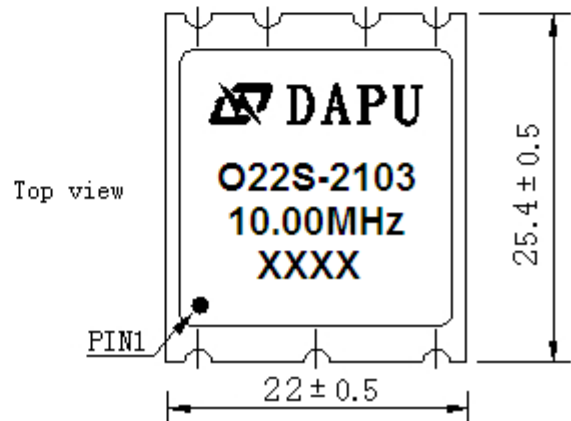

Note1: Tolerance $\pm 0.2\text{mm}$ without mark

Note2: The first two xx representative: week
After two xx representative: year

Note3: Referential Weight 12 g

Note4: NC is not connect

Note5: Material composition :

Pad/terminals: Cu (Surface plating: Ni 3-6um, Au 0.1~0.5um)

Base: High-TG FR4

Cover: Stainless steel



3. I²C Devices Address

3.1.1 8K I²C SERIAL EEPROM

Device name : AT24C08C

Device supplier : Atmel

Device address : 1010100~1010111

3.1.2 EEPROM for inventory and data storage

Address	Total number of bytes	Usage
0x000 – 0x05F	96	Inventory record
0x060 – 0x07F	32	Reserved future inventory format extension
0x080 – 0x1FF	384	Temperature stability correction record
0x0200 – 0x2FF	256	Reserved for aging correction record
0x0300 – 0x3FF	256	Reserved for future use

3.1.3 Inventory record in EEPROM

The inventory record inside the EEPROM will be in the following format. This is a 96 byte format.

Identification Fields	D#	# of bytes	Values (in Hex)
Header	D0	1	80
Function Code: OCSD2	D1-D11	11	5 ASCII bytes to show “OCSD2” See note 1 for unused position filling
Serial Number: “Y ₁ Y ₀ F ₁ F ₀ M ₁ M ₀ N ₅ N ₄ N ₃ N ₂ N ₁ N ₀ ” Y ₁ Y ₀ =year,F ₁ F ₀ =factory code, M ₁ M ₀ =month N ₅ N ₄ N ₃ N ₂ N ₁ N ₀ =unit number	D12-D24	13	Variable Note 1,2, 4
Doc Number	D25-D36	12	9 ASCII bytes to show “DD/045622” See note 1 for unused position filling
Doc Issue No. “I ₁ -I ₀ ” (e.g. 1.5)	D37-D41	5	Note 1,6
Version “SS ₂ :S ₁ S ₀ ” (eg. S4:00)	D42-D47	6	Note 1,4
Supplier’s Part Number : numbering scheme (12-digit)	D48-D62	15	12 ASCII bytes See note 1 for unused position filling See note 5 for value
Supplier Specific Information (If applicable)	D63-D73	11	Note 1
Specific information per function code	D74-D80	7	Note 1, 3
Supplier Code (Supplier’s company name in capital letter)	D81-D94	14	“DAPU” See note 1 for unused position filling
End of File	D95	1	04



3.1.4 Temperature stability correction record in EEPROM

The Temperature stability correction record inside the EEPROM is in following format. This is a 256 byte format.

Identification Fields	D#	# of bytes	Values (in Hex)
Temperature stability correction Record	0x100 – 0x1FF	256	Note 7,8,9,10

Notes

- The I/D values are in ASCII representation except where explicitly noted. Unused positions in a field are filled with the ASCII space character (20h). A null character (00h) is in the last byte of each field, except header and End-of-file. The end-of-file ASCII character (04h) indicates end of inventory data.
- The variable values will be provided by or agreed to by SCN contact for use here.
- This field is reserved for future use
- F1F0 is defined by Supplier to identify different factory of the Supplier to manufacture the part.
SS2:S1S0 is defined by Supplier to differentiate different version of the part.
Every Hardware or software modification must be identified by a new value.
- This part number is specific to each supplier, and must clearly identify the product.
Different values must be used before and after qualification.
- The Doc Issue in inventory is the version used by supplier to design product.
- Address 0x100 indicates temperature sensor value 55°C, address 0x101 indicates temperature sensor value 55.2°C. In this way, increment address when temperature increases every 0.2°C. Therefore, address 0x1FF indicates 106°C.
- Storage of frequency drift: Testing OCXO frequency in environmental temperature range -5°C~+85°C sloop:1°C/1min, take the minimum frequency value f0 as reference point. Variation(frequency drift at other temperature points relate to f0) divide by 0.05ppb, the results are stored to the addresses, frequency drift value is defined as integer. That is:
Frequency drift=((fn-f0)/10,000,000)/0.00,005. For example, when ambient temperature is varying between -5°C ~85°C, internal temperature that temperature sensor detected is varying approximately between 60°C~90°C. Internal temperature detected by sensor and the corresponding frequency variation is as below figure. Find the minimum frequency value f0. Difference between f1 and f0 is 0.2ppb, so store 4 into the related temperature sensor address.

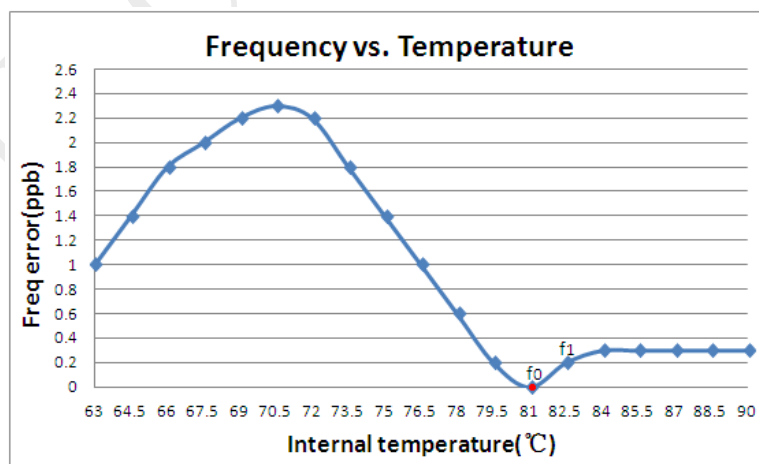

9. Compensation of frequency drift method:

- Read the feedback value from internal temperature sensor and finding the corresponding address, then look up the table of the adjacent addresses.
- Using linear interpolation (or parabolic) methods calculate the correct frequency drift.



c. Calculate crystal drift compensation value by using the frequency drift, through a digital or analog low-pass filter to compensate for output.

10. The formula which reflects correspondence between ambient temperature and the detected internal temperature is as below(This value is only typical, each temperature spot has about $\pm 5^{\circ}\text{C}$ error):

$$Y=0.16 \times B+76$$

B is ambient temperature; Y is the corresponding internal temperature.

3.2. DIGITAL THERMOMETER

Device name: NCT75

Device supplier: ON Semiconductor

Device address: 1001001

Note: More detailed information see the datasheet provide by the ONSEMI.

DAPU Confidential



4. Test Circuit

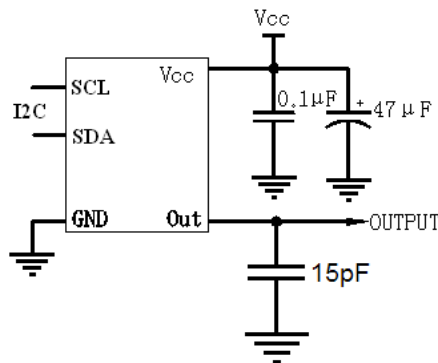

5. Reflow Soldering Curve (RoHS)

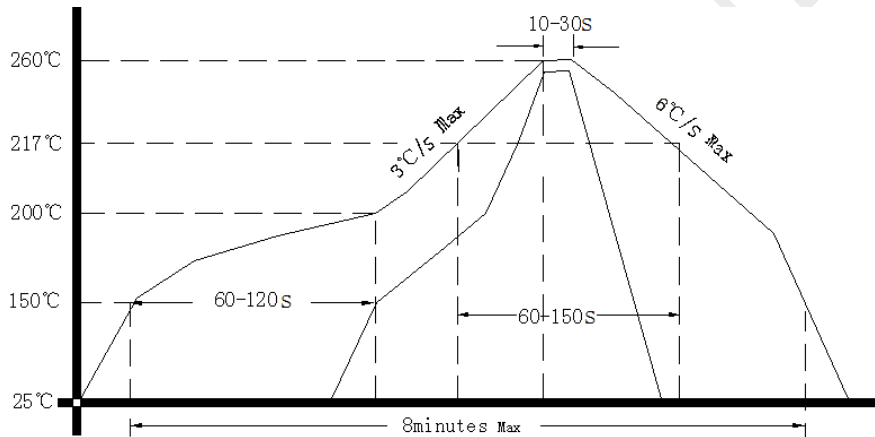

6. Package(mm)

