

Travelling Merchant: _____

DATASHEET

Standard: **O22B-J426-20.00MHz**

P/N: _____

| Plot | | | The Label |
|------------------|---------|----------|------------------------|
| Drew | Audited | Approved | Stamp, please! Thanks! |
| | | | |
| Date: 2014.12.27 | | | |

Guangdong Dapu Telecom Technology Co.,Ltd

Bldg13-16,.N.Ind.Zone,SSL Industry Park, Dongguan City, Guangdong Province, China

TEL: 0086-0769-88010888 FAX: 0086-0769-81800098



Table of amendment

| Version | Revision contents | Prepared by | Revised date |
|---------|-------------------|--------------|--------------|
| 1.0 | The first issued | <i>Amway</i> | 2014.12.27 |
| | | | |
| | | | |
| | | | |
| | | | |
| | | | |
| | | | |
| | | | |
| | | | |
| | | | |
| | | | |
| | | | |
| | | | |
| | | | |
| | | | |
| | | | |
| | | | |
| | | | |
| | | | |
| | | | |
| | | | |
| | | | |



1. Electrical Parameters

| MODEL: O22B-J426-20.00MHz | | | | | | |
|---------------------------|---|------------|------|-------|------------------|--|
| Item | Description | Parameters | | | Unit | Test Condition |
| | | Min. | Typ. | Max. | | |
| Output | Frequency | 20.00 | | | MHz | |
| | Output Waveform | Sine wave | | | | |
| | Level | 6 | | 10 | dBm | |
| | Load | 50 | | | Ω | |
| | Harmonics Suppression | | | -30 | dBc | |
| | Spurious Suppression | | | -60 | dBc | |
| Frequency Stabilities | Frequency Tolerance vs. Operating Temperature Range | -0.01 | | +0.01 | $\times 10^{-6}$ | T_A varied from -30°C to 75°C , measurement referenced to frequency observed with $f_{\text{ref}}=(f_{\text{max}}+f_{\text{min}})/2$, $V_{\text{cc}}=5.0\text{V}$, $V_c=2.5\text{V}$, $O_{\text{load}}=50\Omega$, temperature variable speed less than 2°C per minute. |
| | Initial Frequency Tolerance | -0.05 | | +0.05 | $\times 10^{-6}$ | Measurement referenced to frequency observed with $T_A=25^\circ\text{C}$, $V_{\text{cc}}=5.0\text{V}$, $V_c=2.5\text{V}$ and after 15 minutes of operation, within 30 days after ex-works. |
| | Frequency Tolerance vs. supply voltage | -5 | | +5 | $\times 10^{-9}$ | measurement referenced to frequency observed $T_A=25^\circ\text{C}$, V_{cc} varied from 4.75V to 5.25V, $V_c=2.5\text{V}$, $O_{\text{load}}=50\Omega$. |
| | Frequency Tolerance vs. Load | -5 | | +5 | $\times 10^{-9}$ | 5% Load Change Measurement referenced to frequency observed with $T_A=25^\circ\text{C}$, $V_{\text{cc}}=5.0\text{V}$, $V_c=2.5\text{V}$, $O_{\text{load}}=50\Omega$. |
| | Short Term Stability | | | 0.01 | $\times 10^{-9}$ | Temperature stability, no EMI\EMC or other interference, test after power for 1hour ref. to 25°C ; 1s, using PN9000 equipment. |
| | Aging Tolerance per day | -0.5 | | +0.5 | $\times 10^{-9}$ | V_{cc}, V_c, T_A constant Measurement referenced to frequency observed with $T_A=25^\circ\text{C}$, $V_{\text{cc}}=5.0\text{V}$, $V_c=2.5\text{V}$, $O_{\text{load}}=50\Omega$ and after 30 days of operation. |
| | Aging Tolerance 1 Year | -0.05 | | +0.05 | $\times 10^{-6}$ | |
| Power Supply | Supply Voltage | 4.75 | 5.0 | 5.25 | V | |
| | Current Consumption | | | 400 | mA | @ 25°C |
| | Current Consumption during warm up | | | 1000 | mA | |



| | | | | | | |
|---------------------------------|---|--|------|-------|------------------|--|
| Voltage Control Characteristics | Frequency Tuning Range | -0.8 | | -0.5 | $\times 10^{-6}$ | $V_c=0V$. measurement referenced to $V_c=2.5V$. |
| | | -0.05 | | +0.05 | $\times 10^{-6}$ | $V_c=2.5V$. measurement referenced to exactly 20.00MHz. |
| | | +0.5 | | +0.8 | $\times 10^{-6}$ | $V_c=5.0V$. measurement referenced to $V_c=2.5V$. |
| | Linearity | | | 10 | % | |
| | Slope | Positive | | | | |
| | Input Impedance | 100 | | | | K Ω |
| Phase Noise | Phase Noise @25°C | | -110 | -100 | dBc/Hz | 10Hz |
| | | | -135 | -125 | | 100Hz |
| | | | -145 | -140 | | 1KHz |
| | | | -148 | -143 | | 10KHz |
| | | | -150 | -145 | | 100KHz |
| | | | -150 | -145 | | 1MHz |
| Environmental Conditions | Operable Temperature | -40 | | +85 | °C | |
| | Storage Temperature | -55 | | +105 | °C | |
| | ESD Level | Human Body Model, class2: 2000V to 4000V; ANSI/ESDA/JEDEC JS-001-2010. | | | | |
| | | Machine Model, class B: 200V to 400V; ANSI/ESDA/JEDEC JS-001-2010. | | | | |
| | Moisture Sensitivity Level | Not humidity sensitive. | | | | |
| | Vibration | Test Condition: 0.75mm ;acceleration:10g;10Hz~500Hz, one cycle per 30 min, test 2 hour. (3 times for each 3 directions X ,Y , Z), IEC 68-2-06 Test Fc. | | | | |
| Shock | 50g; 11ms; half sine wave (3 times for each 3 directions X ,Y , Z),IEC 68-2-27 Test Ea/Severity 50A. | | | | | |
| Storage | Relative humidity (%) | 20% ~70% | | | | |
| | Temperature (°C) | -10~35°C | | | | |



2. Mechanical Structure (mm)

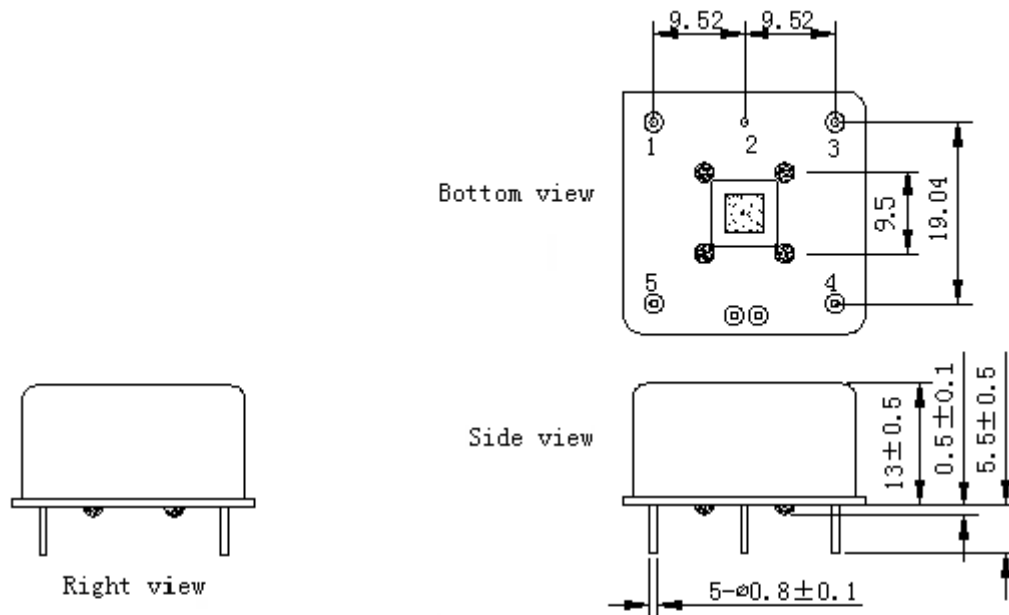

PIN FUNCTION

| PIN | NOTATION | FUNCTION |
|-----|----------|-----------------|
| 1 | OUTPUT | RF Output |
| 2 | GND | GND |
| 3 | VC | Control Voltage |
| 4 | NC | Not Connect |
| 5 | VCC | Supply Voltage |

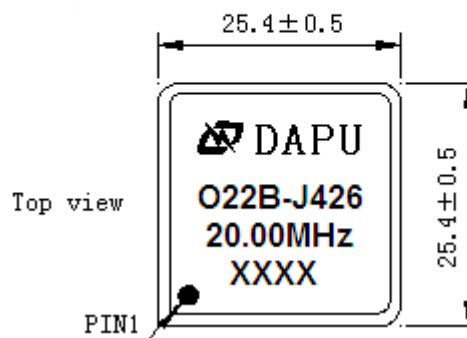

- Note1:** Tolerance ±0.2mm without mark
- Note2:** The first two xx representative: week
After two xx representative: year
- Note3:** Referential Weight 13.6g
- Note4:** NC is not connect



3. Test Circuit

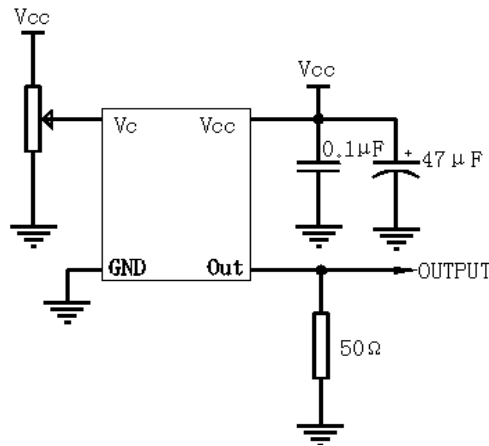

4. Reflow Soldering Curve (RoHS)

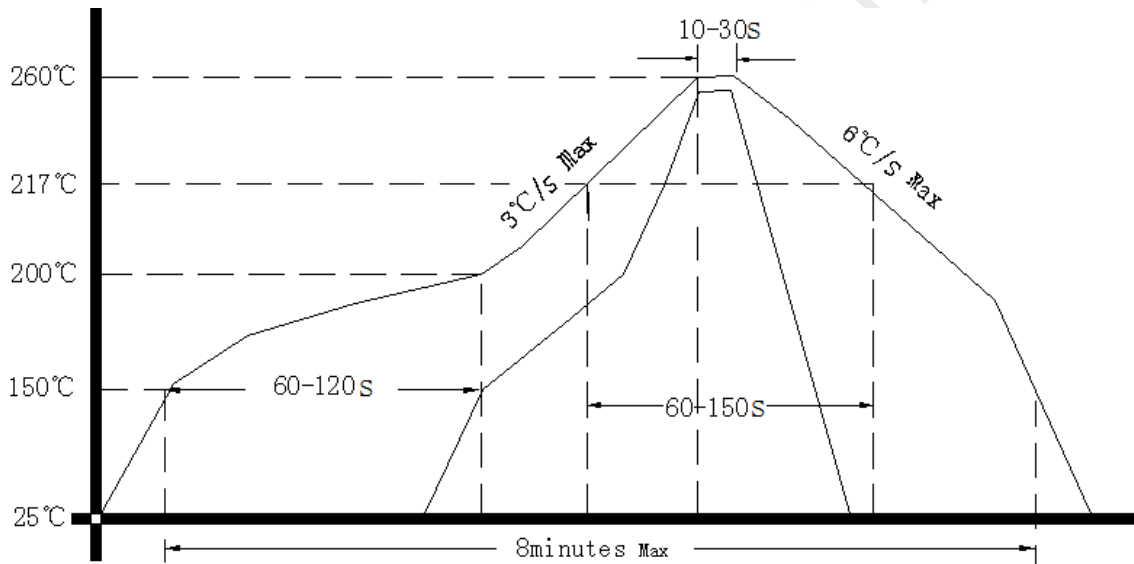

5. Package(mm)

