

Travelling Merchant: \_\_\_\_\_

# DATASHEET

Standard:           **O22L-Q426-100.00MHz-A**          P/N:                                   **2O0100BLLS3**                                  

Plot			The Label
Drew	Audited	Approved	Stamp, please! Thanks!
Date: 2014.12.01			

## Guangdong Dapu Telecom Technology Co.,Ltd

Bldg13-16,.N.Ind.Zone,SSL Industry Park, Dongguan City, Guangdong Province, China

TEL: 0086-0769-88010888    FAX: 0086-0769-81800098





## 1. Electrical Parameters

MODEL: O22L-Q426-100.00MHZ-A						
Item	Description	Parameters			Unit	Test Condition
		Min.	Typ.	Max.		
Output	Frequency	100.00			MHz	
	Output Waveform	Sine wave				
	Level	7			dBm	
	Load	50			$\Omega$	
	Harmonics Suppression			-35	dBc	
	Spurious Suppression			-70	dBc	
Frequency Stabilities	Frequency Tolerance vs. Operating Temperature Range	-0.05		+0.05	$\times 10^{-6}$	$T_A$ varied from $-55^\circ\text{C}$ to $75^\circ\text{C}$ , measurement referenced to frequency observed with $f_{\text{ref}}=(f_{\text{max}}+f_{\text{min}})/2$ , $V_{\text{cc}}=5.0\text{V}$ , $O_{\text{load}}=50\Omega$ , temperature variable speed less than $2^\circ\text{C}$ per minute.
	Initial Frequency Tolerance	-0.5		+0.5	$\times 10^{-6}$	Measurement referenced to frequency observed with $T_A=25^\circ\text{C} \pm 2^\circ\text{C}$ , $V_{\text{cc}}=5.0\text{V}$ , and after 15 minutes of operation, within 30 days after ex-works.
	Frequency Tolerance vs. Supply Voltage	-0.01		+0.01	$\times 10^{-6}$	measurement referenced to frequency observed $T_A=25^\circ\text{C}$ , $V_{\text{cc}}$ varied from 4.75V to 5.25V and $O_{\text{load}}=50\Omega$ .
	Frequency Tolerance vs. Load	-0.01		+0.01	$\times 10^{-6}$	5% load change measurement referenced to frequency observed with $T_A=25^\circ\text{C}$ , $V_{\text{cc}}=5.0\text{V}$ , and $O_{\text{load}}=50\Omega$ .
	Short-Term Stability: Allan Variance			0.1	$\times 10^{-9}$	Temperature stability, no EMI\EMC or other interference, test after power for 1hour ref. to $25^\circ\text{C}$ ; 1s, using PN9000 equipment.
	Aging Tolerance per day	-5		+5	$\times 10^{-9}$	$V_{\text{cc}}, V_c, T_A$ constant Measurement referenced to frequency observed with $T_A=25^\circ\text{C}$ ,
	Aging Tolerance 1 Year	-0.1		+0.1	$\times 10^{-6}$	$V_{\text{cc}}=5.0\text{V}$ , $O_{\text{load}}=50\Omega$ and after 30 days of operation.
Power Supply	Supply Voltage	4.75	5.0	5.25	V	
	Current Consumption			250	mA	@ $25^\circ\text{C} \pm 2^\circ\text{C}$
	Current Consumption during warm up			600	mA	@ $25^\circ\text{C} \pm 2^\circ\text{C}$



Frequency adjust	Frequency Adjust Range			-0.5	$\times 10^{-6}$	$V_c = 0V$ , relative to the nominal frequency.
		+0.5			$\times 10^{-6}$	$V_c = 5.0V$ , relative to the nominal frequency.
Phase Noise	Phase Noise @25°C		-135	-125	dBc/Hz	100Hz
			-160	-155		1KHz
			-165	-160		10KHz
			-170	-165		100KHz
Environmental Conditions	Operable Temperature	-55		+85	°C	
	Storage Temperature	-55		+85	°C	
	ESD Level	Human Body Model, class2: 2000V to 4000V; ANSI/ESDA/JEDEC JS-001-2010.				
		Machine Model, class B: 200V to 400V; ANSI/ESDA/JEDEC JS-001-2010.				
	Moisture Sensitivity Level	Not humidity sensitive.				
	Vibration	Test Condition: 0.75mm ;acceleration:10g;10Hz~500Hz, one cycle per 30 min, test 2 hour. (3 times for each 3 directions X ,Y , Z), IEC 68-2-06 Test Fc.				
Shock	50g; 11ms; half sine wave (3 times for each 3 directions X ,Y, Z ),IEC 68-2-27 Test Ea/Severity 50A.					



## 2. Mechanical Structure (mm)

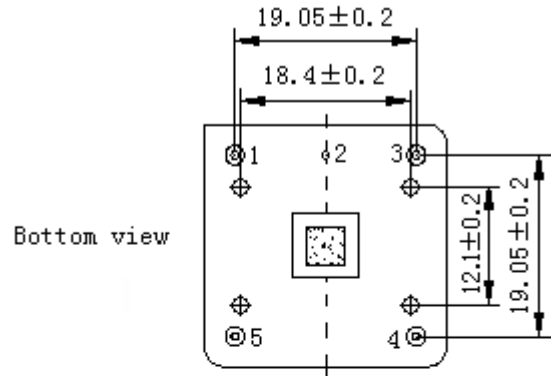
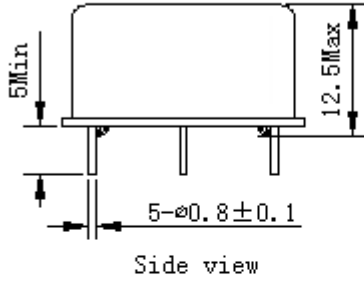

### PIN FUNCTION

PIN	NOTATION	FUNCTION
1	OUTPUT	RF Output
2	GND	GND
3	VC	Control Voltage
4	Vref/NC	Reference Voltage/Not Connect
5	VCC	Supply Voltage

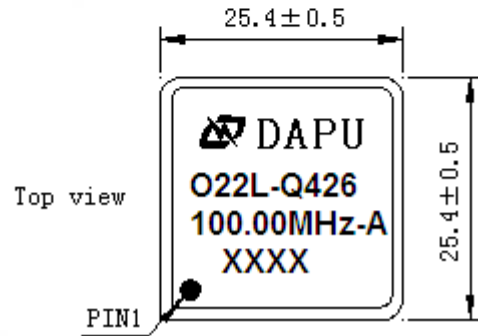

**Note1:** Tolerance  $\pm 0.2\text{mm}$  without mark

**Note2:** The first two xx representative: week  
After two xx representative: year

**Note3:** Referential Weight 30g

**Note4:** NC is not connect

## 3. Test Circuit

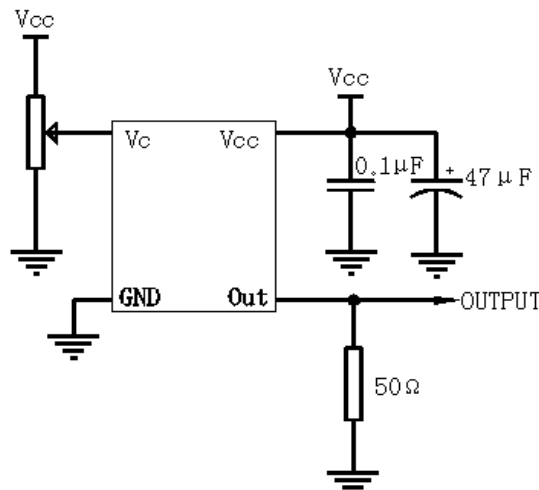

**Note:** Has a built-in bias voltage in voltage controlled .If needn't calibrate the OCXO's frequency, please don't connect the reference voltage and the voltage control pin.



#### 4. Reflow Soldering Curve (RoHS)



#### 5. Package(mm)

