

Travelling Merchant: \_\_\_\_\_

# DATASHEET

Standard:           **O22B-P429-20.00MHz**          

P/N: \_\_\_\_\_

Plot			The Label
Drew	Audited	Approved	Stamp, please! Thanks!
Date: 2014.12.08			

## Guangdong Dapu Telecom Technology Co.,Ltd

Bldg13-16,N.Ind.Zone,SSL Industry Park, Dongguan City, Guangdong Province, China

TEL: 0086-0769-88010888    FAX: 0086-0769-81800098





## 1. Electrical Parameters

MODEL: O22B-P429-20.00MHZ						
Item	Description	Parameters			Unit	Test Condition
		Min.	Typ.	Max.		
Output	Frequency	20.00			MHz	
	Output Waveform	Sine wave				
	Level	6		10	dBm	
	Load	50			$\Omega$	
	Harmonics Suppression			-35	dBc	
	Spurious Suppression			-75	dBc	
Frequency Stabilities	Frequency Tolerance vs. Operating Temperature Range	-0.05		+0.05	$\times 10^{-6}$	$T_A$ varied from $-20^{\circ}\text{C}$ to $70^{\circ}\text{C}$ , measurement referenced to frequency observed with $f_{\text{ref}}=(f_{\text{max}}+f_{\text{min}})/2$ , $V_{\text{cc}}=5.0\text{V}$ , $O_{\text{load}}=50\Omega$ , temperature variable speed less than $2^{\circ}\text{C}$ per minute.
	Initial Frequency Tolerance	-0.5		+0.5	$\times 10^{-6}$	Measurement referenced to frequency observed with $T_A=25^{\circ}\text{C}$ , $V_{\text{cc}}=5.0\text{V}$ , and after 15 minutes of operation, within 30 days after ex-works.
	Frequency Tolerance vs. Supply Voltage	-5		+5	$\times 10^{-9}$	measurement referenced to frequency observed $T_A=25^{\circ}\text{C}$ , $V_{\text{cc}}$ varied from 4.75V to 5.25V, $O_{\text{load}}=50\Omega$ .
	Frequency Tolerance vs. Load	-5		+5	$\times 10^{-9}$	5% load change measurement referenced to frequency observed with $T_A=25^{\circ}\text{C}$ , $V_{\text{cc}}=5.0\text{V}$ , and $O_{\text{Load}}=50\Omega$ .
	Short-Term Stability: Allan Variance			0.01	$\times 10^{-9}$	Temperature stability, no EMI\EMC or other interference, test after power for 1hour ref. to $25^{\circ}\text{C}$ ; 1s, using PN9000 equipment.
	Aging Tolerance Per Day	-1		+1	$\times 10^{-9}$	$V_{\text{cc}}, T_A$ constant measurement referenced to frequency observed with $T_A=25^{\circ}\text{C}$ , $V_{\text{cc}}=5.0\text{V}$ , and after 30 days of operation.
	Aging Tolerance 1 Year	-0.1		+0.1	$\times 10^{-6}$	
Power Supply	Supply Voltage	4.75	5.0	5.25	V	
	Steady Consumption			400	mA	@ $25^{\circ}\text{C}$
	Warm up current			1000	mA	



Phase Noise	Phase Noise @25°C		-110	-100	dBc/Hz	10Hz
			-135	-125		100Hz
			-150	-145		1KHz
			-153	-148		10KHz
			-155	-150		100KHz
			-155	-150		1MHz
Environmental Conditions	Operable Temperature	-40		+85	°C	
	Storage Temperature	-55		+105	°C	
	ESD Level	Human Body Model, class2: 2000V to 4000V; ANSI/ESDA/JEDEC JS-001-2010.				
		Machine Model, class B: 200V to 400V; ANSI/ESDA/JEDEC JS-001-2010.				
	Moisture Sensitivity Level	Not humidity sensitive.				
	Vibration	Test Condition: 0.75mm ;acceleration:10g;10Hz~500Hz, one cycle per 30 min, test 2 hour. (3 times for each 3 directions X ,Y , Z), IEC 68-2-06 Test Fc.				
Shock	50g; 11ms; half sine wave (3 times for each 3 directions X, Y, Z),IEC 68-2-27 Test Ea/Severity 50A.					



## 2. Mechanical Structure(mm)

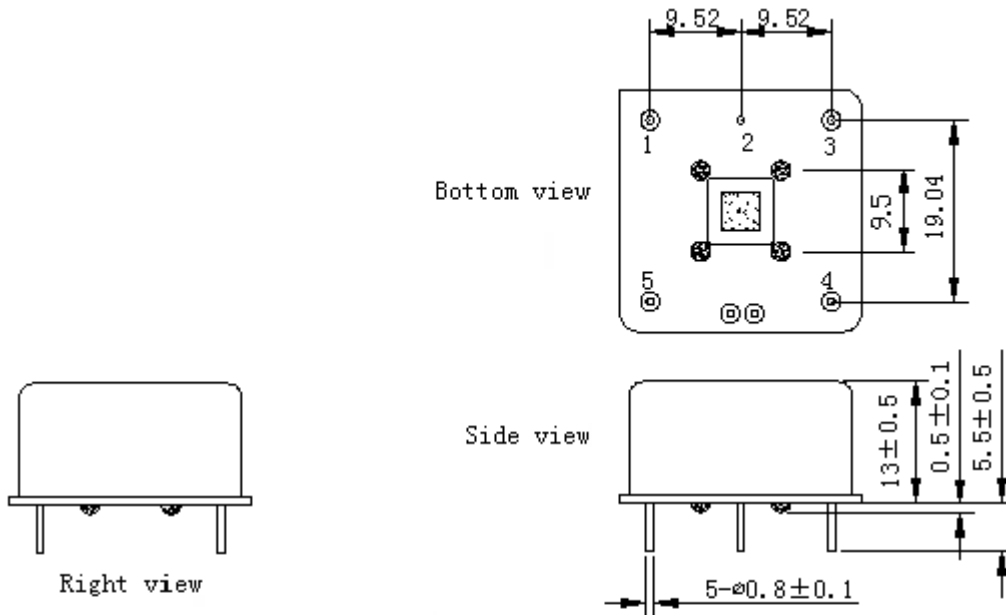

### PIN FUNCTION

PIN	NOTATION	FUNCTION
1	OUTPUT	RF Output
2	GND	GND
3	NC	Not Connect
4	NC	Not Connect
5	VCC	Supply Voltage

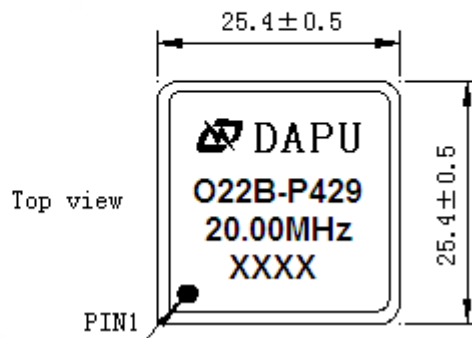

**Note1:** Tolerance ±0.2mm without mark

**Note2:** The first two xx representative: week  
After two xx representative: year

**Note3:** Referential Weight 13.6g

**Note4:** NC is not connect



### 3. Test Circuit

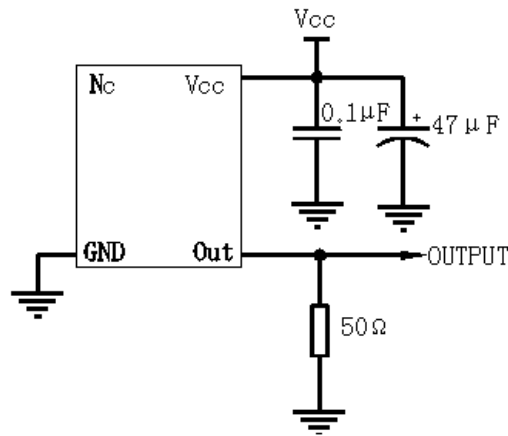

### 4. Reflow Soldering Curve (RoHS)

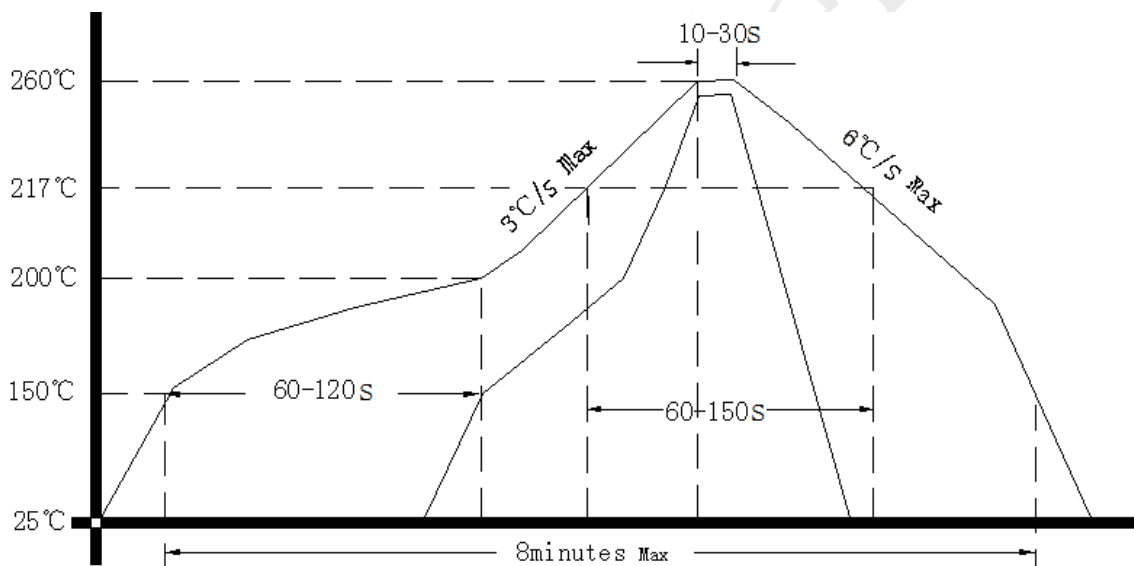

### 5. Package (mm)

