

Travelling Merchant: _____

DATASHEET

Standard: CM55F-K129-10.00MHzP/N: CM-0001

Plot			The Label
Drew	Audited	Approved	Stamp, please! Thanks!
<i>Amway.wei</i>	<i>Steven.Sun</i>	<i>James.Liu</i>	
Date: 2013.12.10			

Guangdong Dapu Telecom Technology Co.,Ltd

Bldg13-16,.N.Ind.Zone,SSL Industry Park, GuangDong City, Guangdong Province, China

TEL: 0086-0769-88010888 FAX: 0086-0769-81800098



1、Electrical Parameters

1 PPS Reference Input	Parameters	Min.	Typ.	Max.	Unit.	Test Condition	
	Waveform	HCMOS					
	High-Level Output Voltage (V_{IH})	2.7			Vdc	50 Ohms	
	Low-Level Output Voltage (V_{IL})			0.4	Vdc		
	Pulse Width	10			uSec		
Connector	Pin 10						
State Input	Parameters	Min.	Typ.	Max.	Unit.	Test Condition	
	Lock Enable	2.7			Vdc	<5mA Load	
	Lock Disable			0.4	Vdc	<5mA Load	
	Connector	Pin 8					
RF Output	Parameters	Min.	Typ.	Max.	Unit.	Test Condition	
	Nominal Frequency		10		MHz		
	Waveform	HCMOS					
	High-level Output voltage (V_{OH})	2.7			Vdc	<5mA Load	
	Low-level Output voltage (V_{OL})			0.4	Vdc	<5mA Load	
	Rise/Fall Time			8	nSec	<5mA Load	
	Duty Cycle	45	50	55	%	<5mA Load	
	Accuracy	-1		1	E-12	24 hour average when locked to 1 PPS	
	Short-term stability			2	E-11	Temperature stability,no EMI\EMC or other interference,test after power for 1 hour ref. to 25°C; 1s, using PN9000 equipment.	
	Phase noise (All conditions)			-118		dBc/Hz	@ 10Hz offset
				-138		dBc/Hz	@ 100Hz offset
				-148		dBc/Hz	@ 1KHz offset
				-150		dBc/Hz	@ 10KHz offset
			-150		dBc/Hz	@ 100KHz offset	
Connector	Pin 14						
Holdover Capability	Holdover Time	Min.	Typ.	Max.	Unit.	Test Condition	
	24 hours	-1.5		+1.5	uSec	$\Delta T = \pm 2^\circ\text{C}$, 24 hours holdover after turn on 7days. Temperature variable speed less than 1°C per minute	

文本



Supply Voltage	Parameters	Min.	Typ.	Max.	Unit.		
	Supply voltage	4.75	5.0	5.25	Vdc		
	Current consumption			1400	mA	During Warm-up	
				600	mA	During steady state operation @25°C	
	AC ripple			50	mVpk-pk	10Hz to 1MHz	
Connector	Pin 3						
1 PPS Output Waveform Characteristics	Parameters	Min.	Typ.	Max.	Unit.		
	Waveform	HCMOS					
	High-Level Output Voltage(V _{OH})	2.7			Vdc	50 Ohms	
	Low-level Output voltage (V _{OL})			0.4	Vdc		
	Pulse width	10			uSec		
	Connector	Pin 12					
State Output	Parameters	Min.	Typ.	Max.	Unit.		
	Lock	2.7			Vdc	<5mA Load	
	Holdover			0.4	Vdc	<5mA Load	
	Connector	Pin 5					
Environmental Conditions	Parameter	Conditions					
	Operating temperature	-20°C to +75°C					
	Storage Temperature	-55°C to +105°C					
	Storage humidity	30%~80%					
	ESD Level	Human Body Model,class2: 2000V to 4000V; ANSI/ESDA/JEDEC JS-001-2010.					
		Machine Model, class B: 200V to 400V; ANSI/ESDA/JEDEC JS-001-2010.					
	Moisture Sensitivity Level	Not humidity sensitive.					
	Vibration	Test Condition: 0.75mm ;acceleration:10g;10Hz~500Hz, one cycle per 30 min, test 2 hours. (3 times for each 3 directions X ,Y , Z), IEC 68-2-06 Test Fc.					
Shock	50g; 11ms; half sine wave (3 times for each 3 directions X ,Y , Z),IEC 68-2-27 Test Ea/Severity 50A.						



2、 Mechanical Structure(mm)

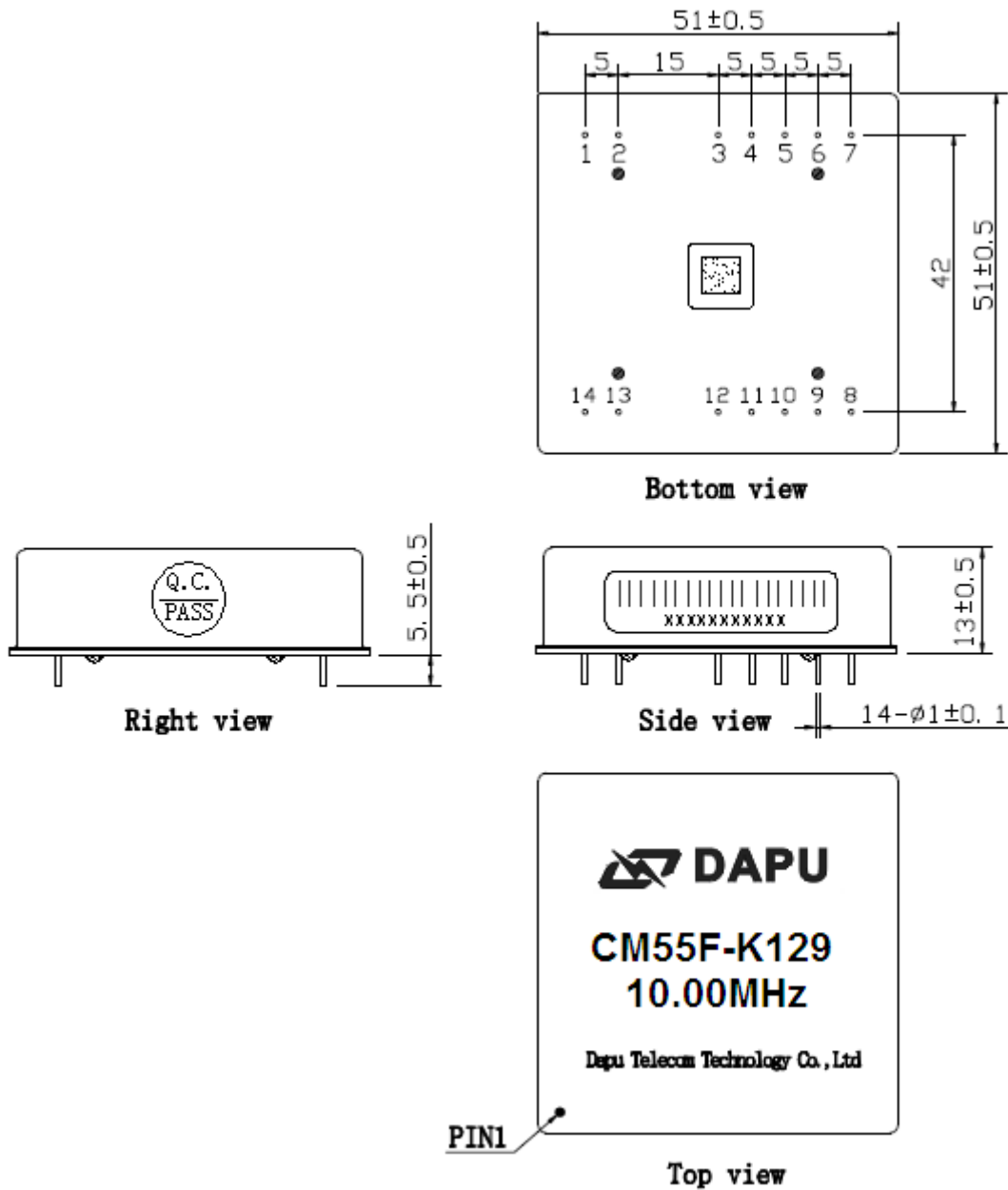

Note1: Tolerance ± 0.2 mm without mark

Note2: Referential Weight 52 ± 5 g



PIN DEFINITION

PIN	Name	DESCRIPTION
3	Vcc +5.0Vdc	Power supply input,4.75V to 5.25V.
5	Lock OUTPUT	State output. Output high level when the work state is Run2(See section 4),others low level.
6	RX INPUT	Asynchronous serial data input.9600-N-8-1.
7	TX OUTPUT	Asynchronous serial data output(See section 5).9600-N-8-1.
8	State INPUT	H: Lock Enable The work state is set to normal operation when the state input is high.
		L: Lock Disable The work state is set to hold over when the state input is low.
9	NC	Not connected.
10	PP1S INPUT	PP1S reference input.
12	PP1S OUTPUT	The clock module PP1S output.
14	10MHz OUTPUT	10MHz OCXO frequency output.
1、 2	NC	Not connected.
4、 11、 13	GND	GND

3、 Functional Block Diagram

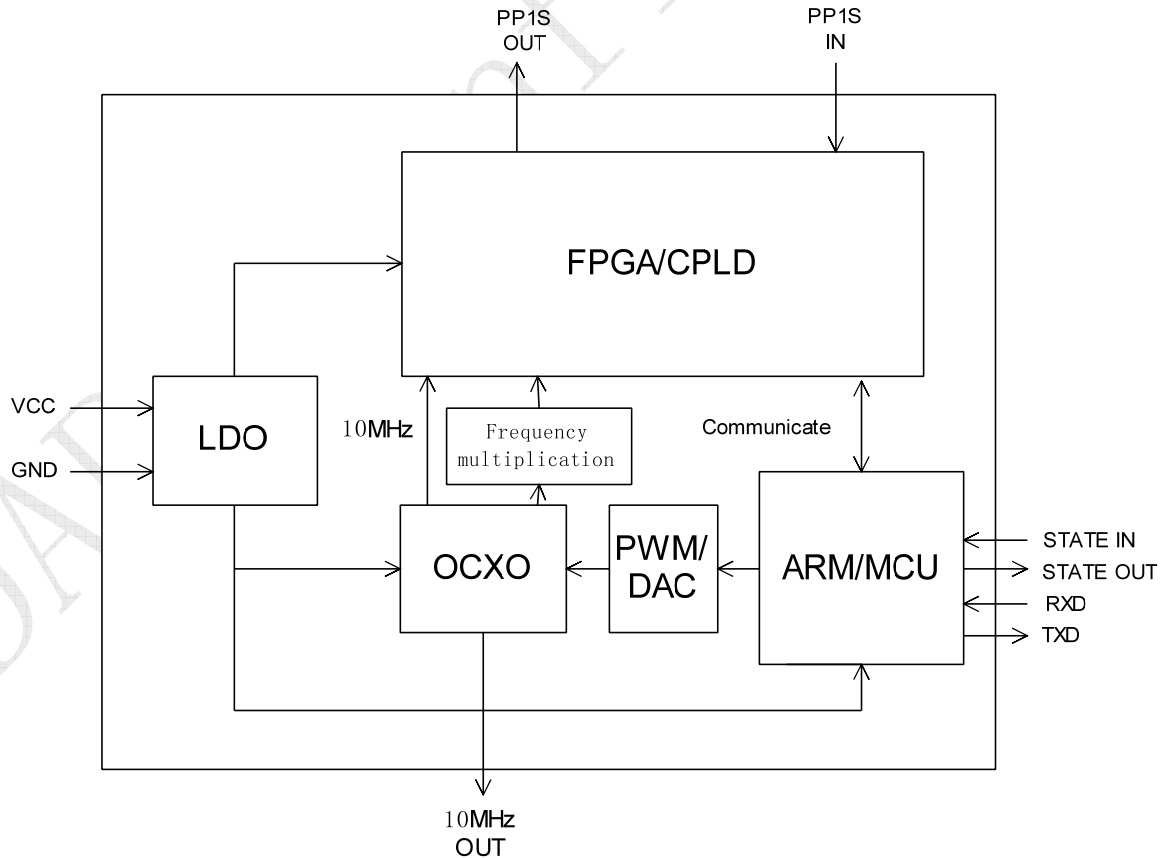



4、 Workflow Diagram

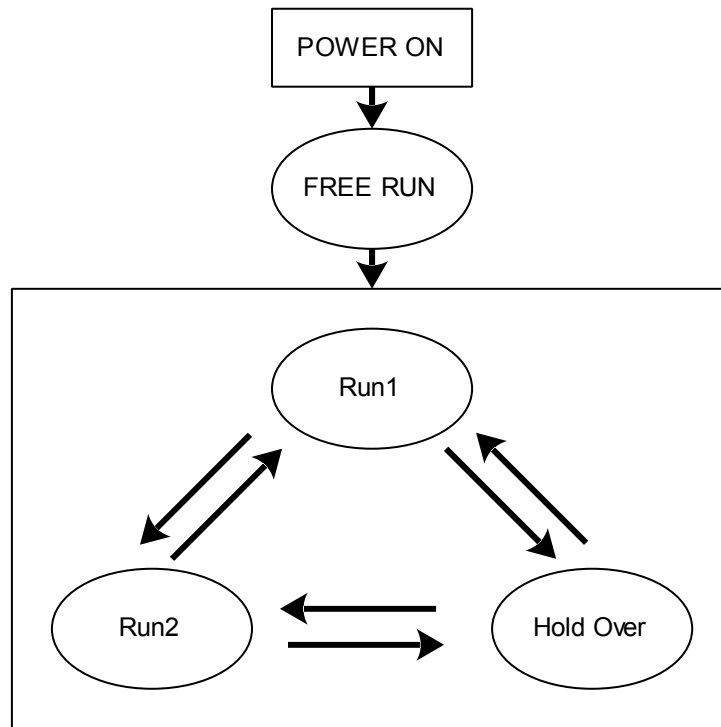

Run1: Fast track. Adjust the OCXO 10MHz output frequency quickly to track the PP1S of 10MHz with PP1S reference.
Run2: Slow track. Adjust the OCXO 10MHz output frequency slowly when the phase error is in the define range.
Hold Over: GPS PP1S reference miss, an algorithm has been developed which enables adaptive modeling of the frequency stability of an OCXO with reference to a GPS timing signal.
Free Run: Clock module power on without PP1S reference anyway.



5、 The Product Test Output Message

Example:

\$PDP,00,0,F,Q,-3095,32768.0000,32768.0000,000,000,00000.0000,00000.0000,00000.0000,00000.0000,3-23,+000.0000,-000,www.dptel.com,1.1,2011-05-16*55

Notes:

In the Format column, c stand for char ,d stand for digit, s stand for sign.

Field No.	Name	Format	Description	Length (byte)
0	\$PDP	\$ccc	Message ID, DAPU Telecom Technology protocol header	4
1	No	dd	Message No.	2
2	TxRxFlag	d	The transmit and receive flag.(0: upper computer transmit; 1: upper computer receive)	1
3	CStatus	c	Current status.(F: 3 mins warm-up; L: Lock; H: Hold over)	1
4	TrackStatus	d	Track status (Q: fast track;1: slow track;S: slow track over 1 hour;S: track over 48 hours)	1
5	cPHDiff	sdddd	Current phase difference	5
6	cPWM1	dddd.dddd	Current PWM1 (Voltage-controlled value1)	10
7	cPWM2	dddd.dddd	Current PWM2 (Voltage-controlled value2)	10
8	SYNCNT	ddd	The synchronous times	3
9	HCNT	ddd	Hours after enter slow track	3
10	HPAVG	dddd.dddd	The average of the PWM in the last 1 hour	10
11	VCH1	dddd.dddd	Voltage-controlled compensation value every 1 hour	10
12	HPMOD	dddd.dddd	The Module PWM Value	
13	VCM10	dddd.dddd	Voltage-controlled compensation value every 10 minutes	10
14	POS	d-dd	The position of the product.(Layer-No), just for the inner test.	4
15	inT	sddd.dddd	NA	9
16	TcPHDiff	sdddd	The product current phase difference	5
17	Website		www.dptel.com	13
18	Version	d.d	version	3
19	Date	ddd-dd-dd	Date	10
20		dd	55	2
21	END		<CR><LF>	2



6、Aplication Information

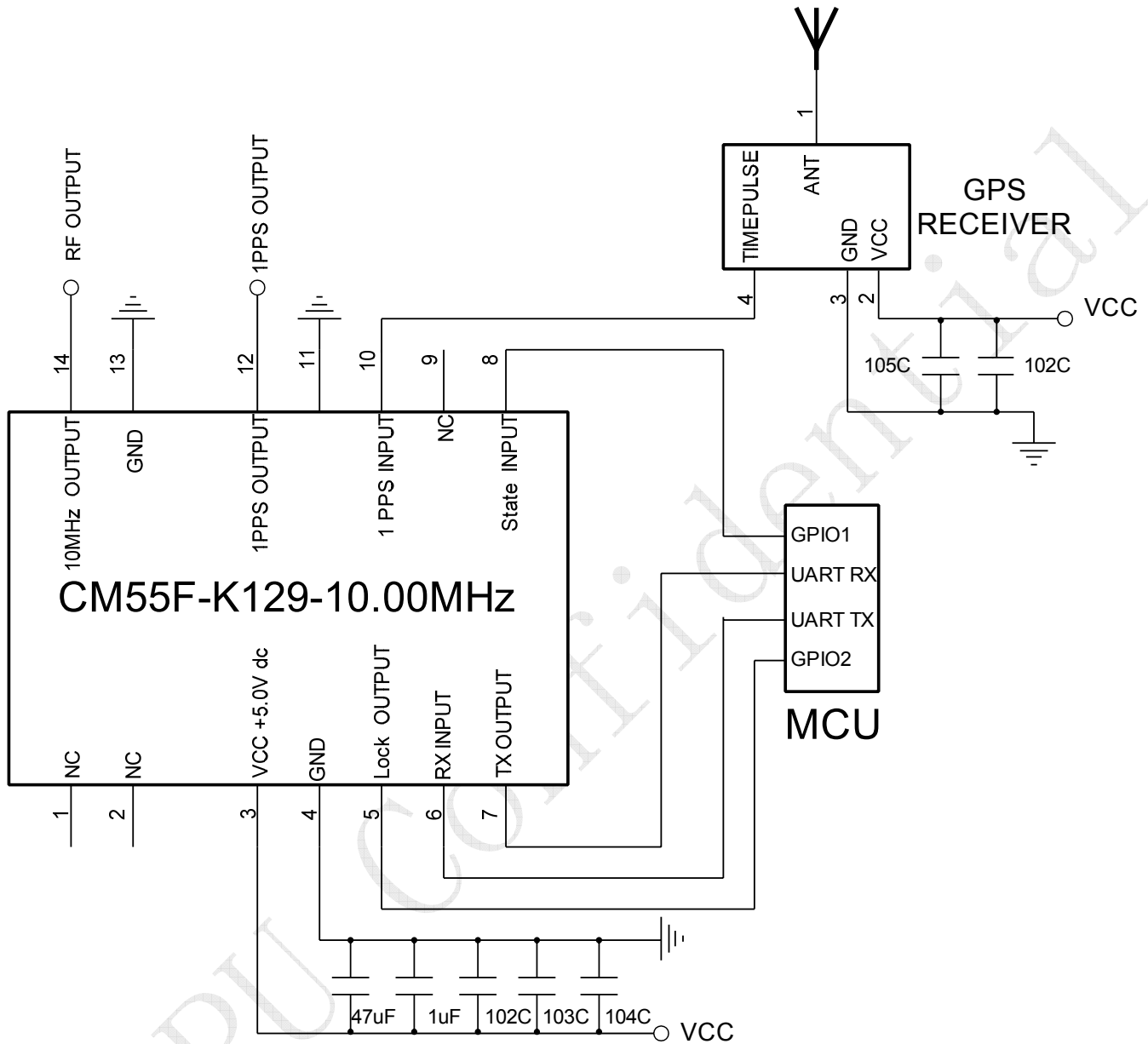

GPS RECEIVER supplies 1PPS signal to the clock module CM55F.

The MCU Monitors the work state of CM55F.

The CM55F is operated with a supply of 5V.

Note1:Power on more than seven days is necessary for the OCXO drift fast in the first four days.

Note2:The adptive model can be built with at least two days good GPS signal. Every time power off will lose the model.

Note3:The work state is set to hold over when the state input is low, no matter the GPS PP1S effective or not.



7、 Coding Rules

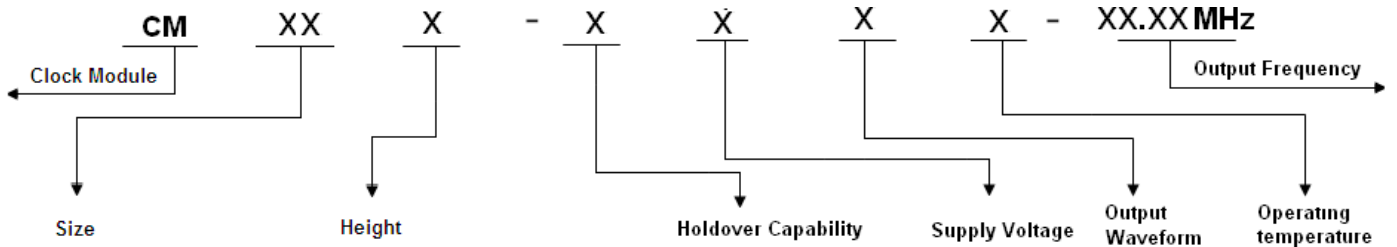

Size	Height	Holdover Capability	Supply Voltage	Output Waveform	Operating temperature
55 50×50 (mm)	A 19mm, single Freq, external GPS receiver	A ±1.5μs 0°C~60°C 24hours	1 5.0V	1 Sine Wave	1 0°C~80°C
66 60×60 (mm)	B 19mm, single Freq, internal GPS receiver	B ±3.0μs 0°C~60°C 24hours		2 HCMOS	2 -10°C~70°C
65 65×65 (mm)	C 19mm, single Freq, internal dual-mode receiver	C ±8.0μs 0°C~60°C 24hours			9 -20°C~75°C
	F 13mm, single Freq, external GPS receiver	D ±1.5μs ΔT=±5°C 24hours			
	G 13mm, single Freq, internal GPS receiver	E ±3.0μs ΔT=±5°C 24hours			
	H 13mm, dual-Freqs, internal GPS receiver	F ±8.0μs ΔT=±5°C 24hours			
	K 13mm, single Freq, internal dual-mode receiver	G ±1.5μs ΔT=±5°C 8hours			
	L 13mm, dual-Freqs, internal dual-mode receiver	H ±3.0μs ΔT=±5°C 8hours			
		I ±8.0μs ΔT=±5°C 8hours			
		K ±1.5μs ΔT=±2°C 24hours			
		M ±3.0μs ΔT=±2°C 24hours			
		N ±8.0μs ΔT=±2°C 24hours			
		O ±1.5μs ΔT=±2°C 8hours			
		P ±3.0μs ΔT=±2°C 8hours			
		Q ±8.0μs ΔT=±2°C 8hours			

8、 Reflow Soldering Curve (RoHS)

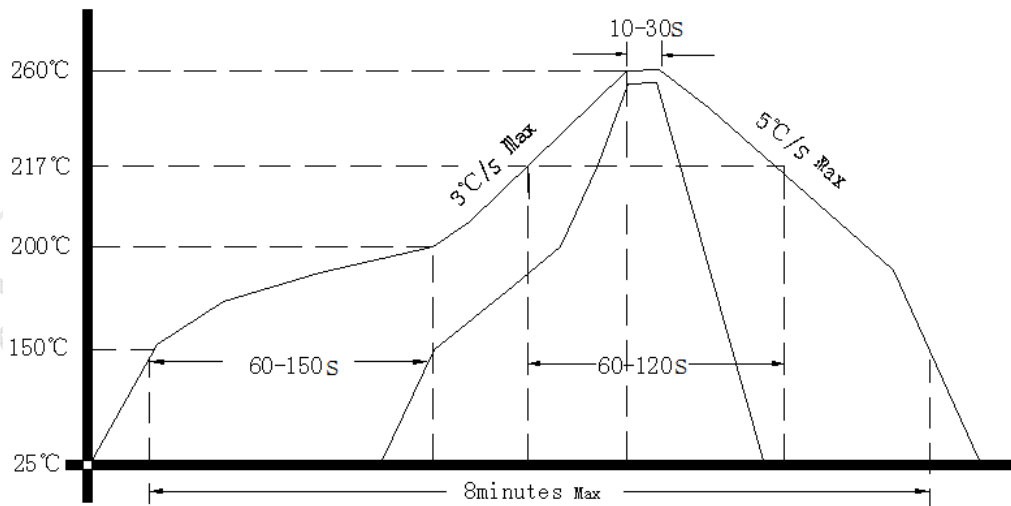



9、Package (mm)

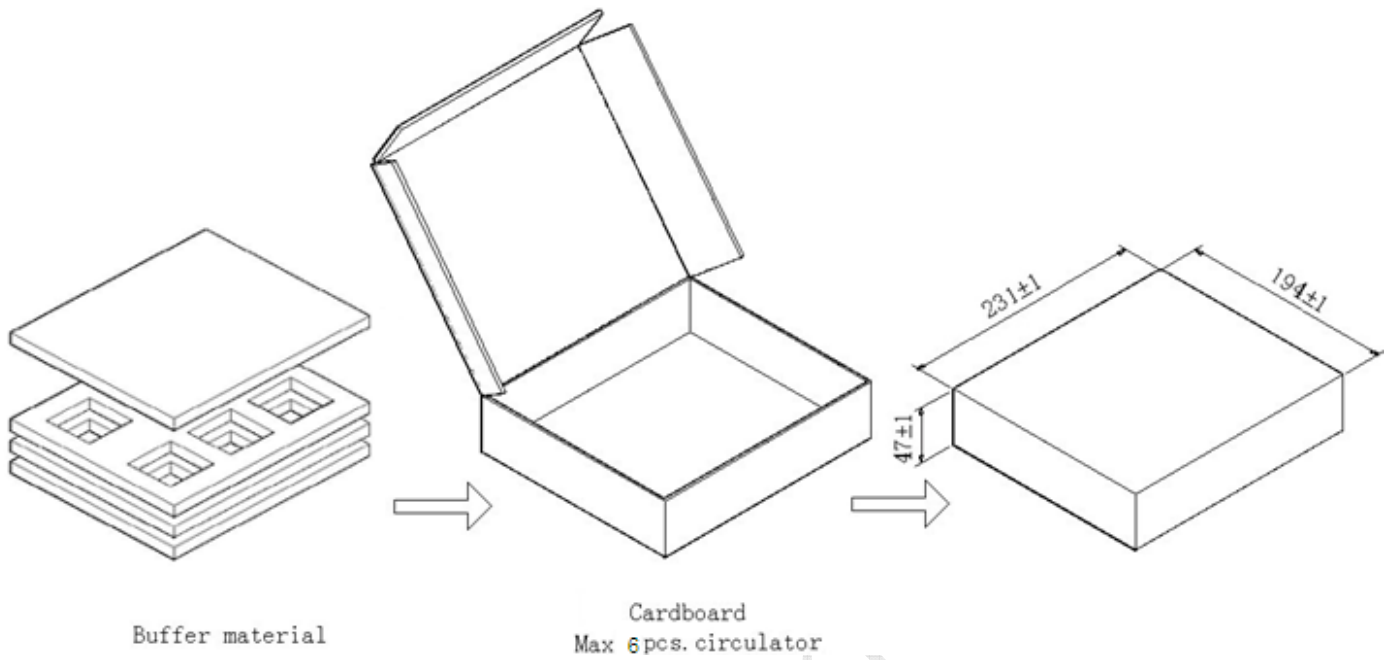

DAPU Config