

Travelling Merchant: \_\_\_\_\_

# DATASHEET

Standard: DP7W81920001Y75YX08190

Plot			The Label
Drew	Audited	Approved	Stamp, please! Thanks!
Date: 2014.07.22			

## Guangdong Dapu Telecom Technology Co.,Ltd

Bldg13-16,.N.Ind.Zone,SSL Industry Park, Dongguan City, Guangdong Province, China

TEL: 0086-0769-88010888 FAX: 0086-0769-81800098



## 1、Electrical Parameters

MODEL: DP7W81920001							
No.	Parameters	SYM.	Electrical Spec.				Notes
			Min.	Typ.	Max.	Units	
1	Nominal Frequency	FO	8.192000			MHz	
2	Mode of Oscillation	OT	Fundamental				
3	Frequency Tolerance	FT	±30			×10 <sup>-6</sup>	Inclusive of supply voltage and load
4	Frequency Stability	-	±30			×10 <sup>-6</sup>	Operating temperature range
5	Operating Temperature range	Topr	-40	~	+85	°C	
6	Storage Temperature range	Tstg	-55	~	+125	°C	
7	Supply Voltage	VDD	5.0±10%			V	
8	Current consumption	OI/Idd	-	-	25	mA	
9	Enable Control	-	Yes			-	
10	Output driving ability	CL/CO	15			pF	
11	Fan out type	LT	CMOS				
12	Output Voltage High	VoH	4.5	-	-	V	
13	Output Voltage Low	Vol	-	-	0.5	V	
14	Rise Time	Tr	-	-	10	ns	10%-90% VDD Level
15	Fall Time	Tf	-	-	10	ns	90%-10% VDD Level
16	Symmetry (Duty ratio)	DT/SY	45	~	55	%	
17	Start-up Time	Tosc	-	-	10	ms	
18	Enable Voltage High	Vhi	70%Vdd	-	-	V	
19	Disable Voltage Low	Vlo	-	-	30%Vdd	V	
20	Aging	-	±3			×10 <sup>-6</sup> /yr.	1st. Year at 25°C
21	ESD Level	Human Body Model,class2: 2000V to 4000V; ANSI/ESDA/JEDEC JS-001-2010.					
		Machine Model, class B: 200V to 400V; ANSI/ESDA/JEDEC JS-001-2010.					
22	Moisture Sensitivity Level	Level 2.					
23	Vibration	Test Condition: 0.75mm ;acceleration:10g;10Hz~2000Hz, one cycle per 30 min, test 2 hour. (3 times for each 3 directions X , Y , Z ).IEC 68-2-06 Test Fc.					
24	Shock	100g; 6ms; half sine wave (3 times for each 3 directions X , Y , Z ),IEC 68-2-27 Test Ea/Severity 50A.					



## 2、Mechanical Structure(mm)

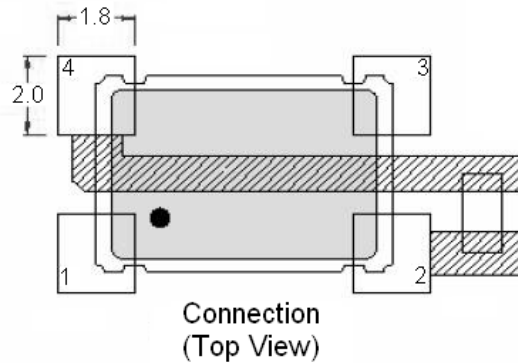
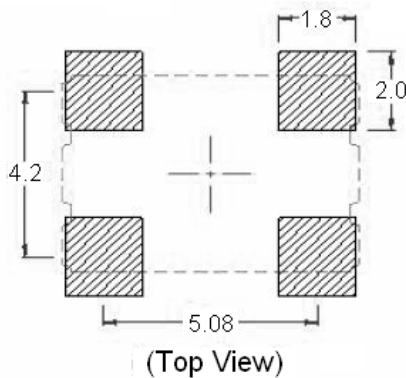
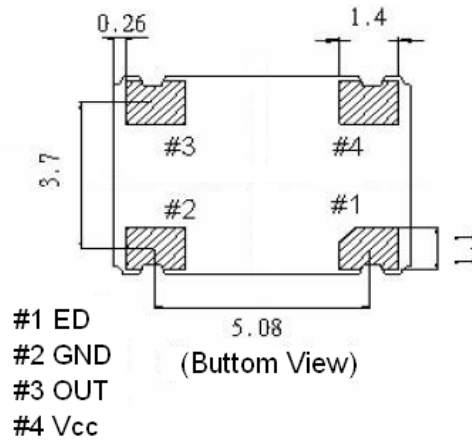
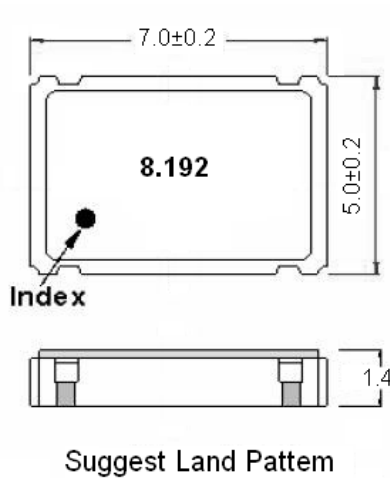

Note1: Tolerance ±0.2mm

## 3、Test Diagram

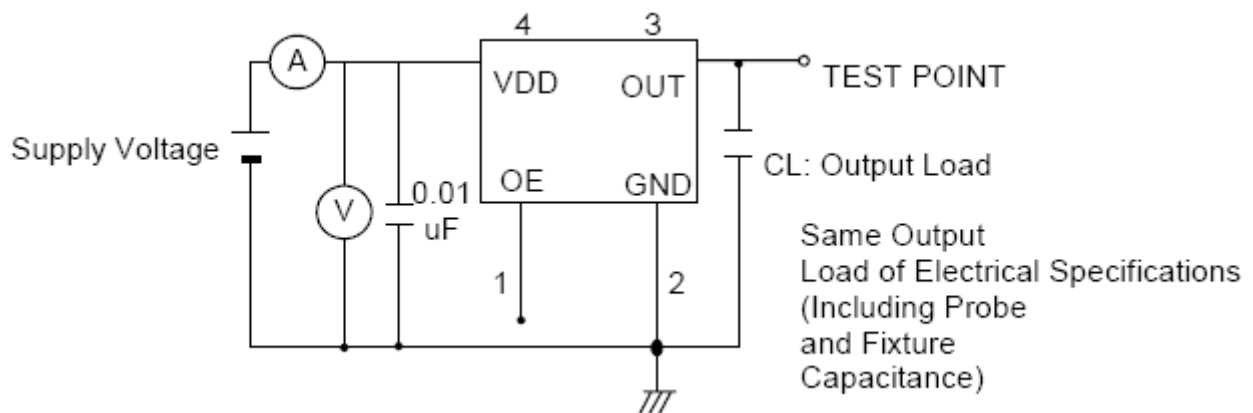

Control input (output enable/disable)

Logic 1 or open on pad 1: Oscillator output

Logic 0 on pad 1 : Disable output to high impedance



#### 4、 Reflow Soldering Curve (RoHS)

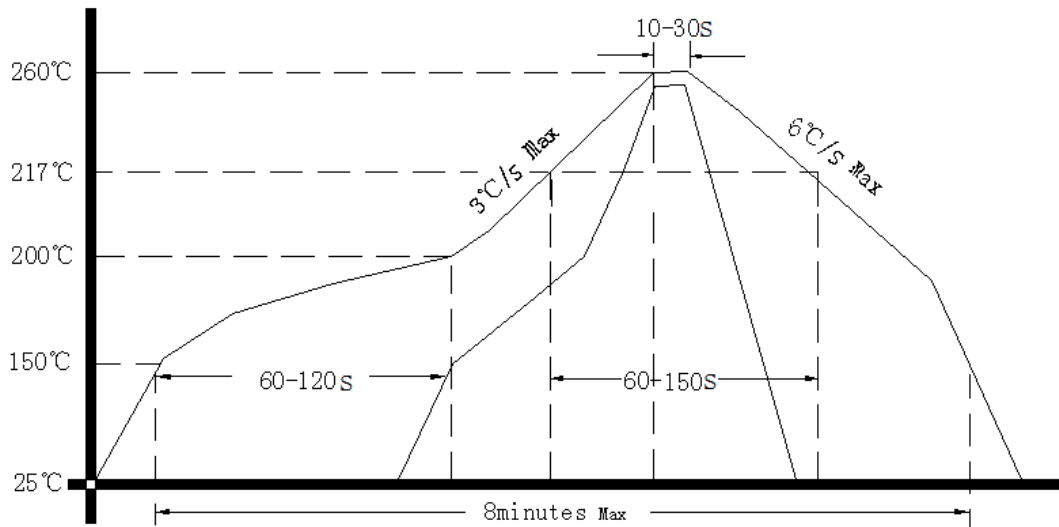

#### 5、 Package: Tape & Reel (mm)

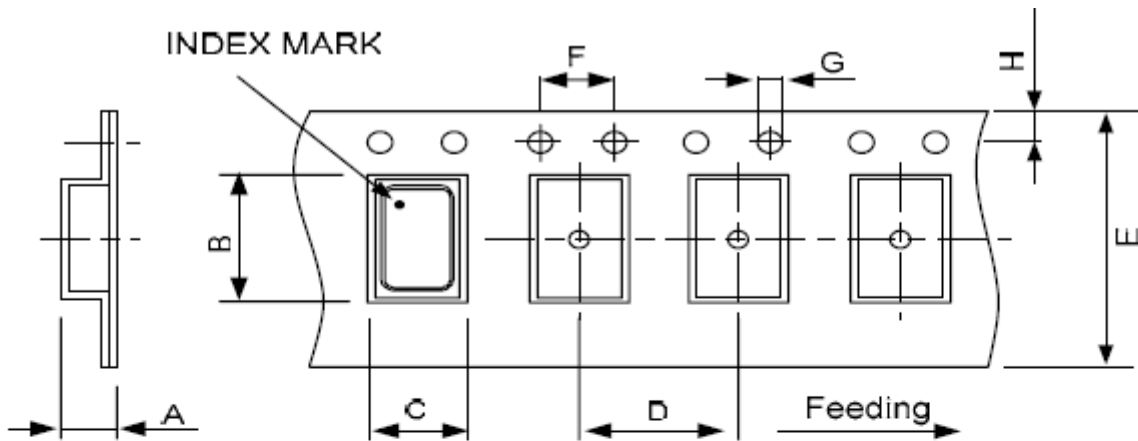

DIMENSIONS	A	B	C	D	E	F	G	H	(UNIT : mm)
	2.30	7.90	5.45	8.00	16.00	4.00	1.50	1.75	

REMARK :

