

Travelling Merchant: \_\_\_\_\_

# DATASHEET

Standard:           **O22B-Y428-100.00MHz**          

P/N: \_\_\_\_\_

Plot			The Label
Drew	Audited	Approved	Stamp, please! Thanks!
Date: 2014.04.21			

## Guangdong Dapu Telecom Technology Co.,Ltd

Bldg13-16,.N.Ind.Zone,SSL Industry Park, Dongguan City, Guangdong Province, China

TEL: 0086-0769-88010888    FAX: 0086-0769-81800098





## 1. Electrical Parameters

MODEL: O22B-Y428-100.00MHZ						
Item	Description	Parameters			Unit	Test Condition
		Min.	Typ.	Max.		
Output	Frequency	100.00			MHz	
	Output Waveform	Sine wave				
	Level	10			dBm	
	Load	50			$\Omega$	
	Harmonics Suppression			-30	dBc	
	Spurious Suppression			-80	dBc	
Frequency Stabilities	Frequency Tolerance vs. Operating Temperature Range	-0.05		+0.05	$\times 10^{-6}$	$T_A$ varied from $-40^\circ\text{C}$ to $70^\circ\text{C}$ , measurement referenced to frequency observed with $f_{\text{ref}}=(f_{\text{max}}+f_{\text{min}})/2$ , $V_{\text{cc}}=5.0\text{V}$ , $V_c=2.5\text{V}$ , $O_{\text{load}}=50\Omega$ , temperature variable speed less than $2^\circ\text{C}$ per minute.
	Initial Frequency Tolerance	-0.5		+0.5	$\times 10^{-6}$	Measurement referenced to frequency observed with $T_A=25^\circ\text{C} \pm 2^\circ\text{C}$ , $V_{\text{cc}}=5.0\text{V}$ , $V_c=2.5\text{V}$ and after 15 minutes of operation, within 30 days after ex-works.
	Frequency Tolerance vs. supply voltage	-0.01		+0.01	$\times 10^{-6}$	measurement referenced to frequency observed $T_A=25^\circ\text{C}$ , $V_{\text{cc}}$ varied from 4.75V to 5.25V, $V_c=2.5\text{V}$ , $O_{\text{load}}=50\Omega$ .
	Aging Tolerance per day	-5		+5	$\times 10^{-9}$	$V_{\text{cc}}, V_c, T_A$ constant Measurement referenced to frequency observed with $T_A=25^\circ\text{C}$ , $V_{\text{cc}}=5.0\text{V}$ ,
	Aging Tolerance 1Year	-0.3		+0.3	$\times 10^{-6}$	$V_c=2.5\text{V}$ , $O_{\text{load}}=50\Omega$ and after 30 days of operation.
Power Supply	Supply Voltage	4.75	5.0	5.25	V	
	Current Consumption			200	mA	@ $25^\circ\text{C} \pm 2^\circ\text{C}$
	Current Consumption during warm up			500	mA	@ $25^\circ\text{C} \pm 2^\circ\text{C}$



Voltage Control Characteristics	Frequency Tuning Range			-1	$\times 10^{-6}$	$V_c=0V$ . measurement referenced to $V_c=2.5V$ .
		-0.5		+0.5	$\times 10^{-6}$	$V_c=2.5V$ . measurement referenced to exactly100.00MHz.
		+1			$\times 10^{-6}$	$V_c=5.0V$ . measurement referenced to $V_c=2.5V$ .
	Linearity			10	%	
	Slope	Positive				
	Input Impedance	100				K $\Omega$
Phase Noise	Phase Noise @25°C		-110	-100	dBc/Hz	10Hz
			-140	-130		100Hz
			-165	-160		1KHz
			-175	-170		10KHz
			-175	-170		100KHz
Environmental Conditions	Operable Temperature	-40		+70	°C	
	Storage Temperature	-55		+85	°C	
	ESD Level	Human Body Model, class2: 2000V to 4000V; ANSI/ESDA/JEDEC JS-001-2010.				
		Machine Model, class B: 200V to 400V; ANSI/ESDA/JEDEC JS-001-2010.				
	Moisture Sensitivity Level	Not humidity sensitive.				
	Vibration	Test Condition: 0.75mm ;acceleration:10g;10Hz~500Hz, one cycle per 30 min, test 2 hour. (3 times for each 3 directions X ,Y , Z), IEC 68-2-06 Test Fc.				
Shock	50g; 11ms; half sine wave (3 times for each 3 directions X ,Y , Z ),IEC 68-2-27 Test Ea/Severity 50A.					



## 2. Mechanical Structure (mm)

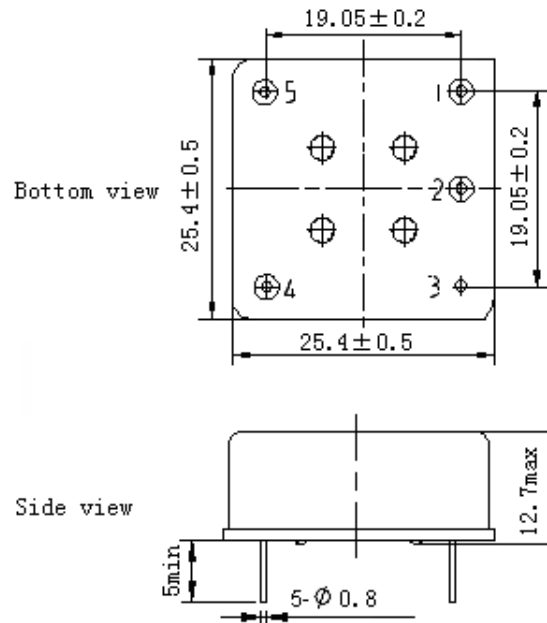

PIN FUNCTION

PIN	FUNCTION
1	OUTPUT
2	GND
3	VC
4	Vref/NC
5	Vcc

- Note1:** Tolerance ±0.2mm without mark  
**Note2:** The first two xx representative: week  
 After two xx representative: year  
**Note3:** Referential Weight 13.6g  
**Note4:** NC is not connect

## 3. Test Circuit

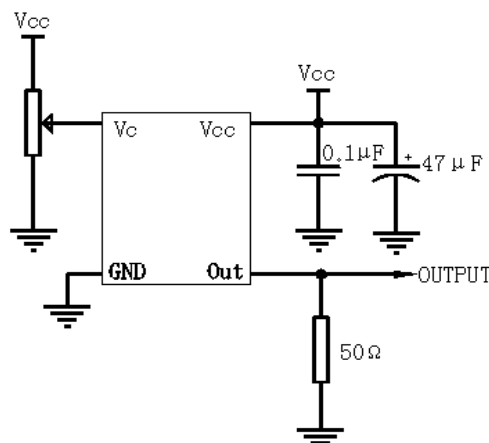



#### 4. Reflow Soldering Curve (RoHS)

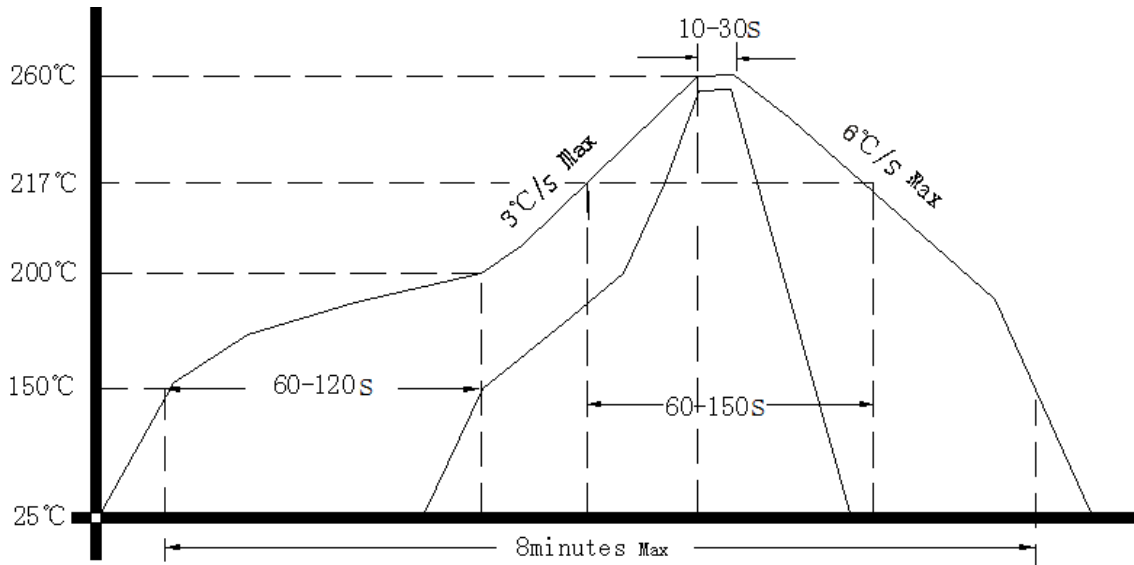

#### 5. Package(mm)

