

Travelling Merchant: _____

DATASHEET

Standard: OS70504A-ACAN-50.00MHz

Plot			The Label
Drew	Audited	Approved	Stamp, please! Thanks!
Date:			

Guangdong Dapu Telecom Technology Co.,Ltd

Bldg13,.N.Ind.Zone,SSL Industry Park, Dongguan City, Guangdong Province, China

TEL: 0086-0769-88010888 FAX: 0086-0769-81800098



1. Electrical Parameters

MODEL: OS70504A-ACAN-50.00MHz						
Item	Description	Parameters			Unit	Test Condition
		Min.	Typ.	Max.		
Output	Frequency	50.00			MHz	
	Output Waveform	LVCMOS				
	Output Low Voltage			+0.33	V	V _{CC} =3.3V, O _{load} =15pF
	Output High Voltage	+2.97			V	V _{CC} =3.3V, O _{load} =15pF
	Duty Cycle	45	50	55	%	@50%
	Rise / Fall Time (10%~90%)		5		ns	@25°C
	Load		15		pF	
Frequency Stabilities	Frequency Tolerance vs. Operating Temperature Range	-25		+25	ppm	T _A varied from- 40°C to 85°C, measurement referenced to frequency observed with T _A = 25°C, V _{CC} =3.3V, O _{load} =15pF
	Initial Frequency Tolerance	-15		+15	ppm	Measurement referenced to frequency observed with T _A = 25°C, V _{CC} =3.3V, and after 5s of operation, within 30 days after ex-works
	Frequency Tolerance vs. Load	-3		+3	ppm	5% load change measurement referenced to frequency observed with T _A =25°C, V _{CC} =3.3 V, O _{load} =15pF
	Aging Tolerance 1 Year	-5		+5	ppm	V _{CC} , T _A constant measurement referenced to frequency observed with T _A =25°C, V _{CC} = 3.3V, and after 30 days of operation
Power Supply	Current Consumption			25	mA	@25°C, V _{CC} =3.3V, O _{load} =15pF
	Supply Voltage		+3.3		V	unalterable
Environmental Conditions	Operable Temperature	-40		+85	°C	
	Storage Temperature	-50		+105	°C	
	Vibration	Test Condition: 0.75mm ;acceleration:10g;10Hz~2000Hz, one cycle per 30 min, test 2 hour. (3 times for each 3 directions X , Y , Z).				
	Shock	100g; 6ms; half sine wave (3 times for each 3 directions X , Y , Z),IEC 68-2-27 Test Ea/Severity 50A.				
	Drop	Test Condition: free drop on steel-made surface or rigid, plane from a height of 100cm, IEC 68-2-32.				



2. Mechanical Structure (mm)

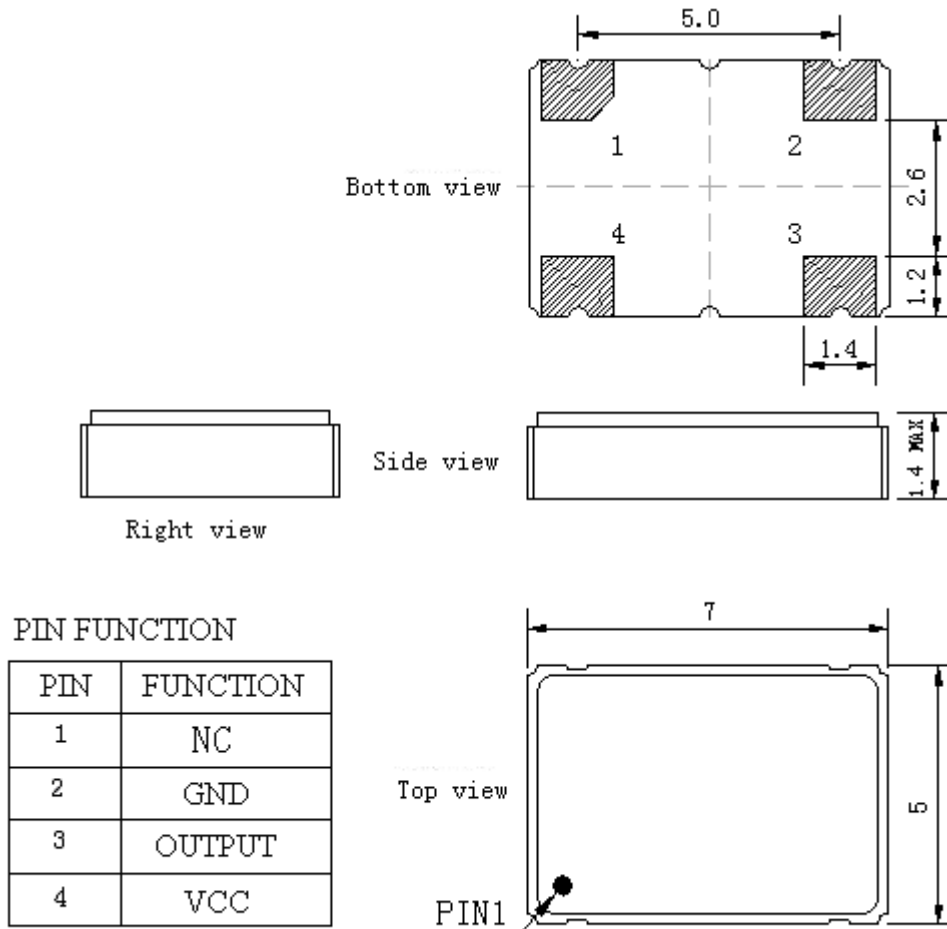

PIN FUNCTION

PIN	FUNCTION
1	NC
2	GND
3	OUTPUT
4	VCC

* Tolerance $\pm 0.1\text{mm}$ without mark

Notel: Referential Weight 0.2g

3. Test Circuit

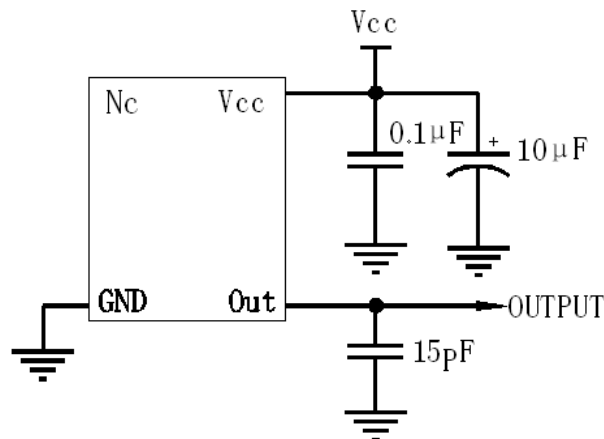



4. Reflow Soldering Curve (RoHS)

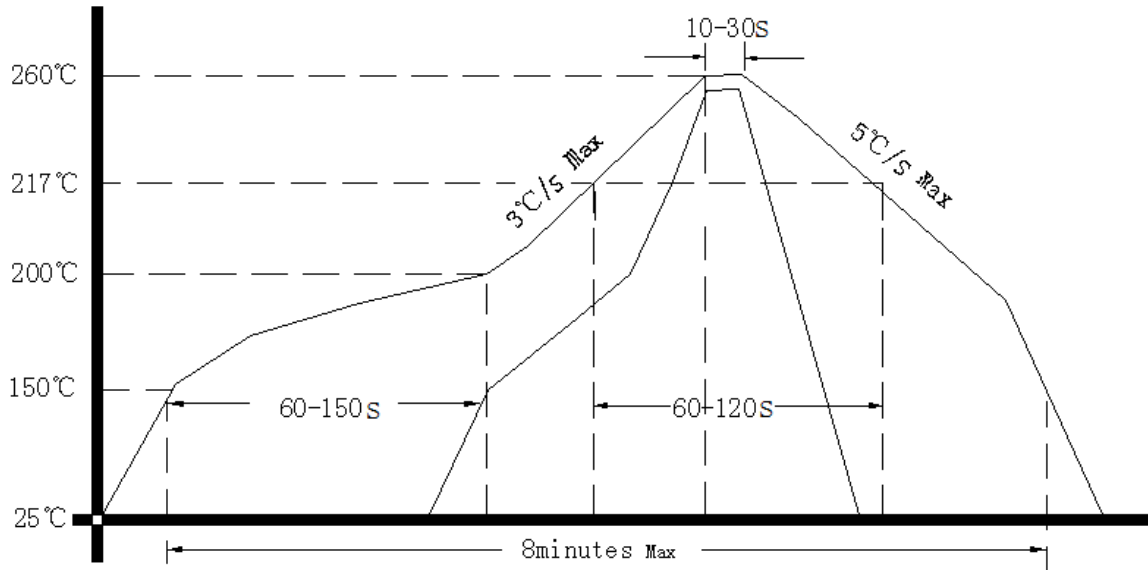

5. Package: Tape & Reel (mm)

