



1、电性能

型号: T75B-K819-24.00MHz						
项目	指标描述	指标			单位	测试条件
		最小值	典型值	最大值		
输出	频率	24.00			MHz	
	波形	LVCMOS				
	低电平			0.4	V	V _{cc} =3.3 V, O _{load} =15pF
	高电平	2.4			V	V _{cc} =3.3 V, O _{load} =15pF
	占空比	45	50	55	%	@50%
	上升/下降时间			5	ns	10%~90%
	带载	15			pF	
频率稳定度	温度特性	-2.5		+2.5	ppm	温度范围-40℃ 到 85℃, 参照 T _A =25℃, V _{cc} = 3.3V, O _{load} = 15pF.
	初始频率准确度	-1		+1	ppm	参照 T _A = 25℃, V _{cc} =3.3V,测试结果; 出厂后 30 天内,开机 5s 后测试.
	日老化	-0.02		+0.02	ppm	参照 T _A = 25℃, V _{cc} = 3.3V,测试结果, 开机 30 天后 连续测试.
	年老化	-1		+1	ppm	
电气特性	电流		5		mA	@25℃
	供电电压		+3.3		V	
相位噪声	相噪		-130		dBc/Hz	1KHz
环境条件	可工作温度	-40		+85	℃	
	存储温度	-50		+90	℃	
	振动	测试条件: 0.75mm ;加速度:10g;10Hz~2000Hz, 每 30 分钟为一个循环, 每个方向测试 2 小时 (3 个方向 X, Y, Z), IEC 68-2-06 Test Fc.				
	冲击	100g; 6ms; 半正弦波(3 个方向 X, Y, Z),IEC 68-2-27 Test Ea/Severity 50A.				
	跌落	从100cm高度自由下坠到混凝土或钢制成的平滑、坚硬的刚性表面IEC 68-2-32.				



2、机械结构(mm)

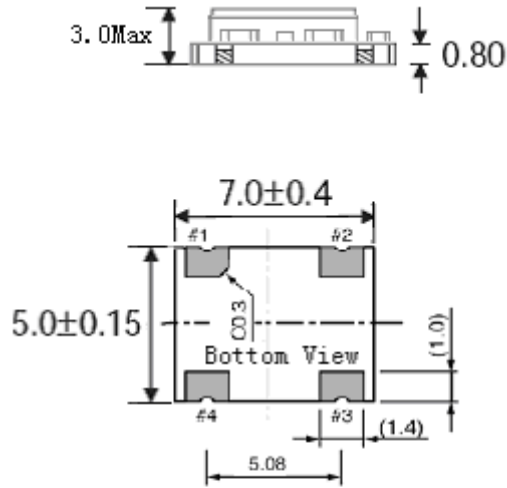

Pin Connections

#1	NC
#2	GND
#3	Output
#4	Vcc

注:底视图为焊盘正对着观察者, 参考重量约为0.3g

单位: mm

3、电路图

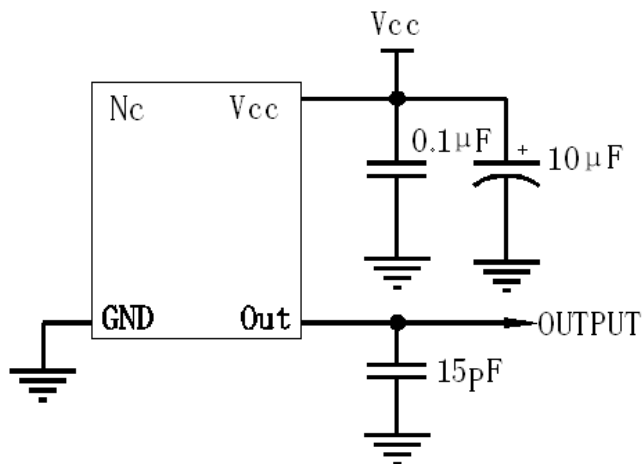



3、回流焊曲线图(RoHS)

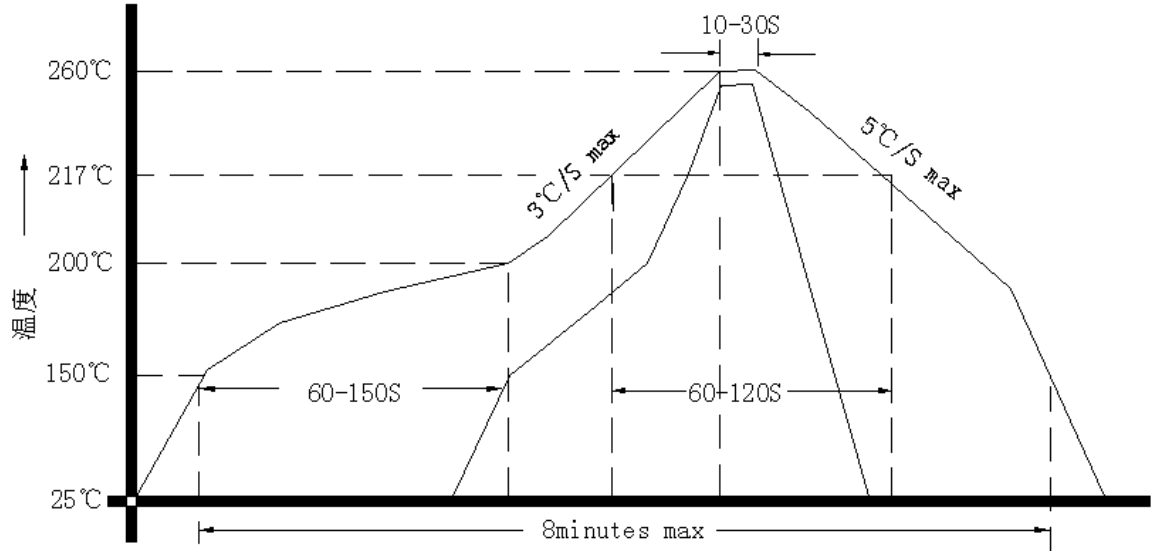

4、载带盘装 (单位:mm)

