

Travelling Merchant: _____

DATASHEET

Standard: **O23C-F429-100.00MHz**

P/N: _____

Plot			The Label
Drew	Audited	Approved	Stamp, please! Thanks!
Date: 2014.04.09			

Guangdong Dapu Telecom Technology Co.,Ltd

Bldg13-16,N.Ind.Zone,SSL Industry Park, Dongguan City, Guangdong Province, China

TEL: 0086-0769-88010888 FAX: 0086-0769-81800098



1. Electrical Parameters

MODEL: O23C-F429-100.00MHz						
Item	Description	Parameters			Unit	Test Condition
		Min.	Typ.	Max.		
Output	Frequency	100.00			MHz	
	Output Waveform	Sine wave				
	Level	4		8	dBm	
	Load	50			Ω	
	Harmonics Suppression			-35	dBc	
	Spurious Suppression			-65	dBc	
Frequency Stabilities	Frequency Tolerance vs. Operating Temperature Range	-0.03		+0.03	$\times 10^{-6}$	T_A varied from -20°C to 70°C , measurement referenced to frequency observed with $f_{ref}=(f_{max}+f_{min})/2$, $V_{cc}=5.0\text{V}$, $O_{load}=50\Omega$, temperature variable speed less than 2°C per minute.
	Initial Frequency Tolerance	-0.1		+0.1	$\times 10^{-6}$	Measurement referenced to frequency observed with $T_A=25^{\circ}\text{C}$, $V_{cc}=5.0\text{V}$, and after 15 minutes of operation, within 30 days after ex-works.
	Frequency Tolerance vs. Supply Voltage	-0.01		+0.01	$\times 10^{-6}$	measurement referenced to frequency observed $T_A=25^{\circ}\text{C}$, V_{cc} varied from 4.75V to 5.25V, $O_{load}=50\Omega$.
	Frequency Tolerance vs. Load	-0.01		+0.01	$\times 10^{-6}$	5% load change measurement referenced to frequency observed with $T_A=25^{\circ}\text{C}$, $V_{cc}=5.0\text{V}$, and $O_{Load}=50\Omega$.
	Short-Term Stability: Allan Variance			0.01	$\times 10^{-9}$	Temperature stability, no EMI\EMC or other interference, test after power for 1 hour ref. to 25°C ; 1s, using PN9000 equipment.
	Aging Tolerance Per Day	-5		+5	$\times 10^{-9}$	V_{cc}, T_A constant measurement referenced to frequency observed with $T_A=25^{\circ}\text{C}$, $V_{cc}=5.0\text{V}$, and after 30 days of operation.
	Aging Tolerance 1 Year	-0.1		+0.1	$\times 10^{-6}$	
Power Supply	Supply Voltage	4.75	5.0	5.25	V	
	Steady Consumption			500	mA	@ 25°C
	Warm up current			1000	mA	



Phase Noise	Phase Noise @25°C		-110	-100	dBc/Hz	10Hz
			-130	-120		100Hz
			-150	-145		1KHz
			-160	-155		10KHz
			-165	-160		100KHz
Environmental Conditions	Operable Temperature	-40		+85	°C	
	Storage Temperature	-55		+105	°C	
	ESD Level	Human Body Model, class2: 2000V to 4000V; ANSI/ESDA/JEDEC JS-001-2010.				
		Machine Model, class B: 200V to 400V; ANSI/ESDA/JEDEC JS-001-2010.				
	Moisture Sensitivity Level	Not humidity sensitive.				
	Vibration	Test Condition: 0.75mm ;acceleration:10g;10Hz~500Hz, one cycle per 30 min, test 2 hour. (3 times for each 3 directions X ,Y , Z), IEC 68-2-06 Test Fc.				
Shock	50g; 11ms; half sine wave (3 times for each 3 directions X, Y, Z),IEC 68-2-27 Test Ea/Severity 50A.					



2. Mechanical Structure(mm)

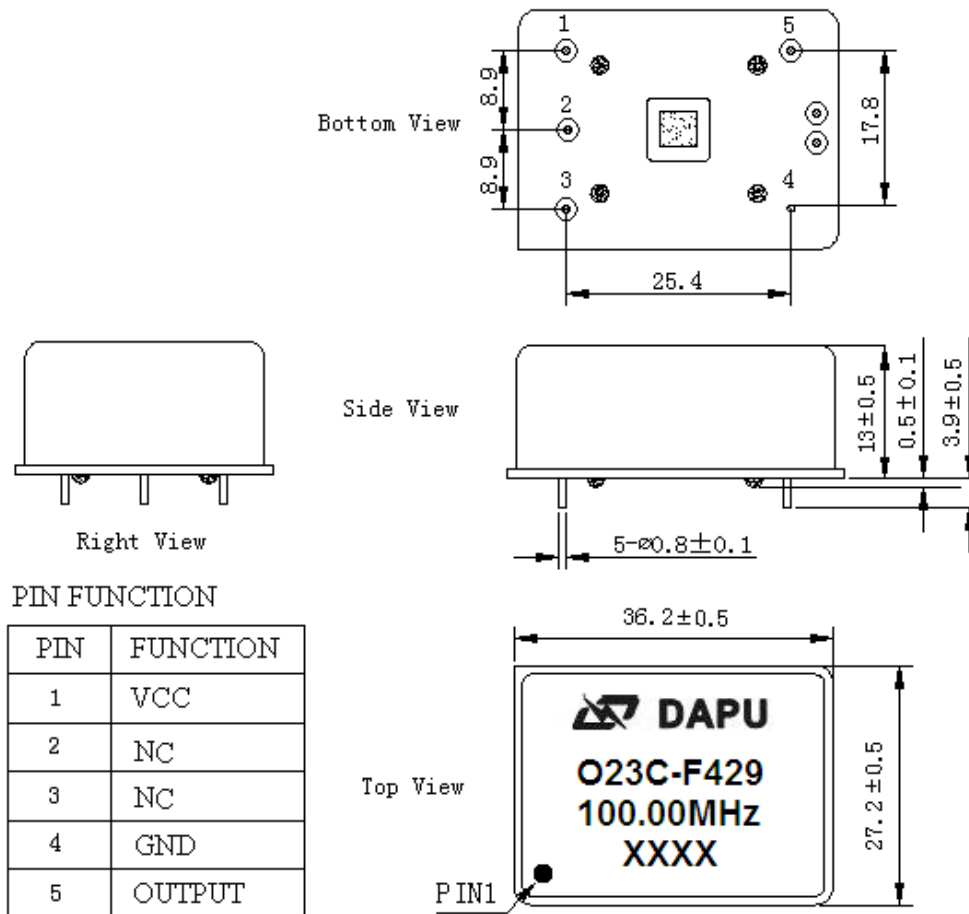

PIN FUNCTION

PIN	FUNCTION
1	VCC
2	NC
3	NC
4	GND
5	OUTPUT

Note1: Tolerance ±0.2mm without mark

Note2: The first two xx representative: week
After two xx representative: year

Note3: Referential Weight 17.0g

Note4: NC is not connect

3. Test Circuit

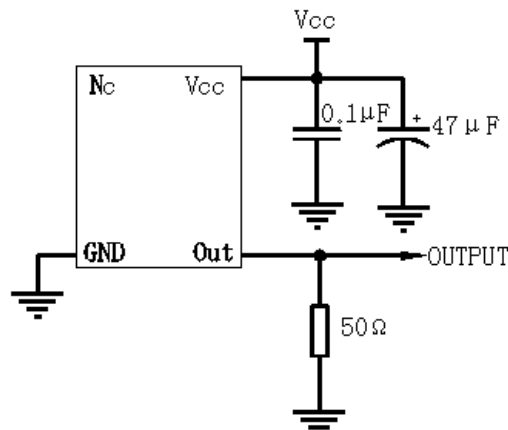



4. Reflow Soldering Curve (RoHS)



5. Package (mm)

