

Travelling Merchant: \_\_\_\_\_

# DATASHEET

Standard:     **T53-H512-40.00MHz-A**    

P/N: \_\_\_\_\_

Plot			The Label
Drew	Audited	Approved	Stamp, please! Thanks!
Date: 2013.11.12			

## Guangdong Dapu Telecom Technology Co.,Ltd

Bldg13-16,.N.Ind.Zone,SSL Industry Park, Dongguan City, Guangdong Province, China

TEL: 0086-0769-88010888    FAX: 0086-0769-81800098





## 1. Electrical Parameters

MODEL: T53-H512-40.00MHz-A						
Item	Description	Parameters			Unit	Test Condition
		Min.	Typ.	Max.		
Output	Frequency	40.00			MHz	
	Output Waveform	Clipped Sine Wave				
	Vp-p	0.8			V	
	Load	10KΩ//10pF				
Frequency Stabilities	Frequency Tolerance vs. Operating Temperature Range	-2		+2	$\times 10^{-6}$	$T_A$ varied from $-45^{\circ}\text{C}$ to $85^{\circ}\text{C}$ , measurement referenced to frequency observed with $T_A=25^{\circ}\text{C}$ , $V_{cc}=3.3\text{V}$ , $V_c=1.5\text{V}$ , $O_{load}=10\text{K}\Omega//10\text{pF}$ , temperature variable speed less than $2^{\circ}\text{C}$ per minute.
	Nominal Frequency Tolerance	-1		+1	$\times 10^{-6}$	Measurement referenced to frequency observed with $T_A=25^{\circ}\text{C}$ , $V_{cc}=3.3\text{V}$ , $V_c=1.5\text{V}$ within 30 days after ex-works.
	Frequency Tolerance vs. Supply Voltage	-0.2		+0.2	$\times 10^{-6}$	measurement referenced to frequency observed $T_A=25^{\circ}\text{C}$ , $V_{cc}$ varied from 3.13V to 3.47V, $V_c=1.5\text{V}$ and $O_{Load}=10\text{K}\Omega//10\text{pF}$ .
	Frequency Tolerance vs. Load	-0.2		+0.2	$\times 10^{-6}$	5% load change measurement referenced to frequency observed with $T_A=25^{\circ}\text{C}$ , $V_{cc}=3.3\text{V}$ , $V_c=1.5\text{V}$ and $O_{Load}=10\text{K}\Omega//10\text{pF}$ .
	Aging Tolerance Per Day	-0.02		+0.02	$\times 10^{-6}$	$T_A=25^{\circ}\text{C}$ , $V_{cc}=3.3\text{V}$ , $V_c=1.5\text{V}$ and after 1h of operation.
	Aging Tolerance 1 Year	-1		+1	$\times 10^{-6}$	
Power Supply	Operating Current			3	mA	@ $25^{\circ}\text{C}$ , $V_{cc}=3.3\text{V}$ , $V_c=1.5\text{V}$ , $O_{Load}=10\text{K}\Omega//10\text{pF}$ .
	Supply Voltage	3.13	3.3	3.47	V	



Voltage Control	Frequency tuning range			-8	$\times 10^{-6}$	$V_c=0.5V$ . measurement referenced to $V_c=1.5V$ .
		-1		+1	$\times 10^{-6}$	$V_c=1.5V$ . measurement referenced to Exactly 40.00MHz.
		+8			$\times 10^{-6}$	$V_c=2.5V$ . measurement referenced to $V_c=1.5V$ .
	Linearity			10	%	
	Slope	Positive				
Input Impedance	100				K $\Omega$	
Phase Noise	Phase Noise @25°C		-80	-75	dBc/Hz	10Hz
			-105	-100		100Hz
			-130	-125		1KHz
			-145	-140		10KHz
			-150	-145		100KHz
			-150	-145		1MHz
Environmental Conditions	Operable Temperature	-45		+85	°C	
	Storage Temperature	-55		+105	°C	
	ESD Level	Human Body Model,class2: 2000V to 4000V; ANSI/ESDA/JEDEC JS-001-2010.				
		Machine Model, class B: 200V to 400V; ANSI/ESDA/JEDEC JS-001-2010.				
	Moisture Sensitivity Level	Level 2.				
	Vibration	Test Condition: 0.75mm ;acceleration:10g;10Hz~2000Hz, one cycle per 30 min, test 2 hour. (3 times for each 3 directions X ,Y , Z) .IEC 68-2-06 Test Fc.				
Shock	100g; 6ms; half sine wave (3 times for each 3 directions X ,Y , Z ),IEC 68-2-27 Test Ea/Severity 50A.					



## 2. Mechanical Structure(mm)

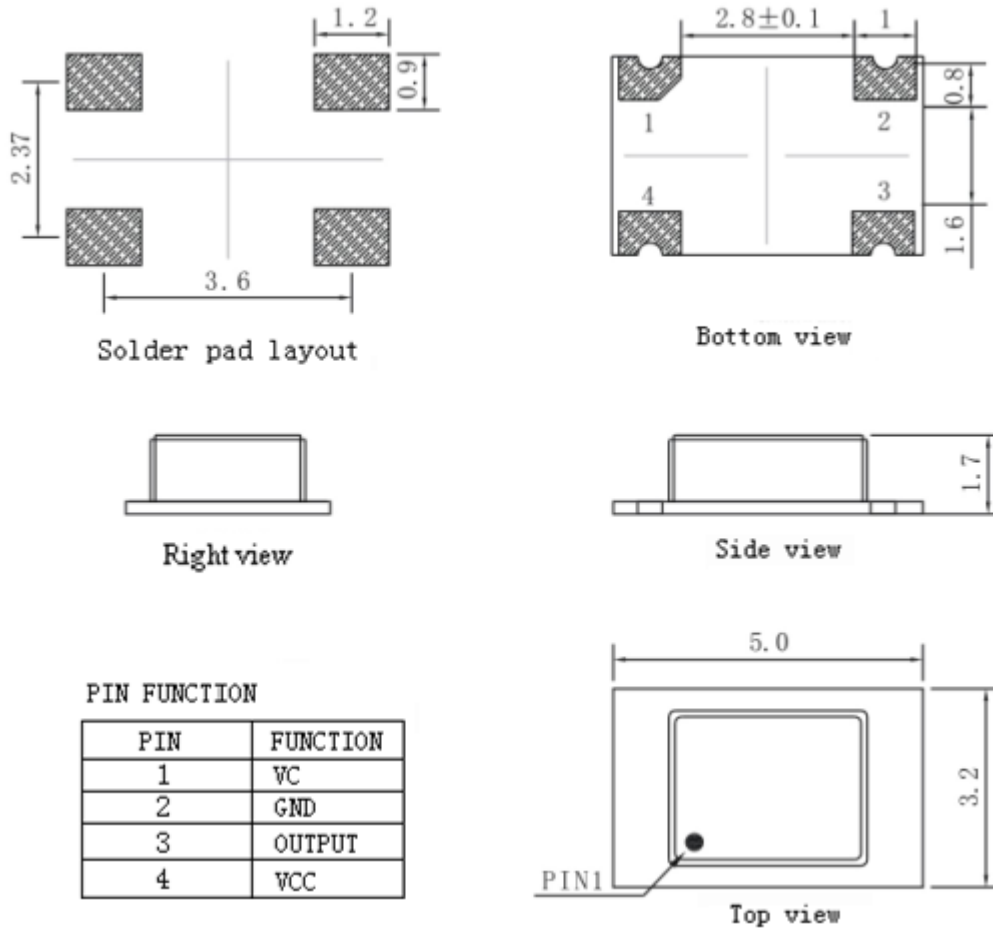

**Note1:** Tolerance  $\pm 0.1\text{mm}$  without mark

**Note2** Referential Weight 0.05g

## 3. Test Circuit

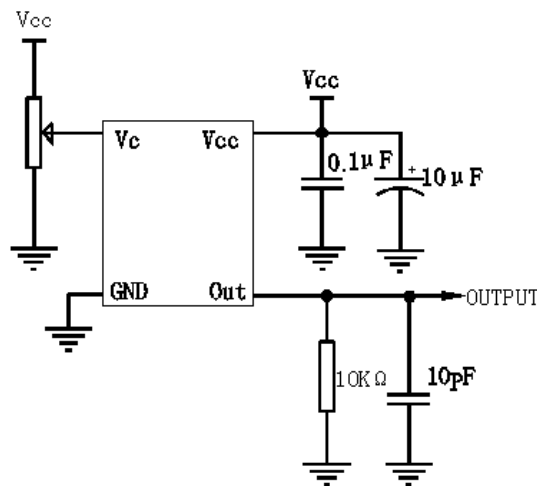



#### 4. Reflow Soldering Curve (RoHS)



#### 5. Package: Tape & Reel (mm)

