



# INS5710C —Low Power Consumption Temperature Compensation I<sup>2</sup>C RTC

## Key Features

- Low Current Consumption: 1.0uA (Typ.)
- High Stability:  
±20ppm @ -20°C ~ +70°C
- Build-in XO: 32.768kHz
- Build-in Temperature Sensor
- Communication Interface: I<sup>2</sup>C bus
- Power Supply Voltage: 1.6V~5.5V
- Operation Temperature Range: -40°C ~ +85°C
- Leap Years Autocorrection
- Package: 4.9mm × 6.0mm × 1.6mm (SOP8)

## Ordering Information

Part Name	Manufacture Part Number (MPN)	Package	Marking
INS5710C	INS5710C	SOP8	5710C

## Block Diagram

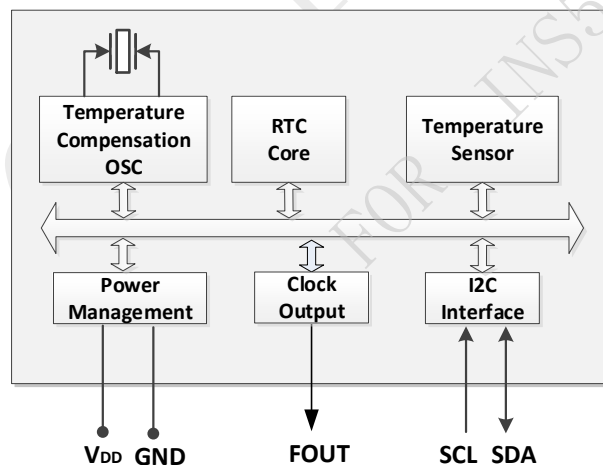

## Overview

INS5710C is a low-power RTC chip with temperature compensation function. It embeds a 32.768kHz XO. It supports calendar (year, month, day, hour, minute, second) function. The SOP8 package makes it suitable to be used in portable electronic devices.



## Revision History

Version	Change Contents	Prepared by	Revised Date
V1.0	Released Version		2022.3.20
V1.1	Improve the information in Figure 5		2022.4.20
V1.2	1. Add FOUT PIN description and FOUT frequency configuration. 2. Temperature characteristic range adjustment. "5 ± 20ppm @ -40°C ~ 85°C" before, and "± 20ppm @ -20°C ~ 70°C" after.		2022.8.29



# Index

<b>1</b>	<b>OVERVIEW</b> .....	<b>5</b>
<b>2</b>	<b>BLOCK DIAGRAM</b> .....	<b>5</b>
<b>3</b>	<b>FEATURES</b> .....	<b>5</b>
<b>4</b>	<b>PIN DEFINITION</b> .....	<b>6</b>
<b>5</b>	<b>ELECTRICAL CHARACTERISTICS</b> .....	<b>7</b>
5.1	ABSOLUTE MAXIMUM RATINGS .....	7
5.2	RECOMMENDED OPERATING CONDITIONS.....	7
5.3	FREQUENCY CHARACTERISTICS .....	7
5.4	DC CHARACTERISTICS .....	7
5.5	AC CHARACTERISTICS.....	8
<b>6</b>	<b>REGISTER</b> .....	<b>10</b>
6.1	REGISTER LIST .....	10
6.2	DETAILS OF REGISTERS.....	12
6.2.1	<i>Clock counter registers</i> .....	12
6.2.2	<i>Extension registers</i> .....	13
6.2.3	<i>Flag registers</i> .....	13
6.2.4	<i>Control registers</i> .....	13
6.2.5	<i>Temperature register</i> .....	14
6.2.6	<i>RSV register</i> .....	14
6.2.7	<i>Device ID register</i> .....	14
6.2.8	<i>Control Register 1</i> .....	14
6.2.9	<i>Sub-second timer register</i> .....	14
6.2.10	<i>Extension Register</i> .....	14
<b>7</b>	<b>I<sup>2</sup>C BUS INTERFACE</b> .....	<b>15</b>
7.1	CAUTIONS.....	15
7.2	SLAVE ADDRESS .....	15
7.3	I <sup>2</sup> C BUS PROTOCOL .....	15
7.3.1	<i>Write process</i> .....	15



---

7.3.2	Read process.....	16
8	REFLOW SOLDERING CURVE.....	17
9	DIMENSIONS.....	18
10	PACKAGE INFORMATION.....	19

DAPU CONFIDENTIAL  
FOR INS5710C



# 1 Overview

INS5710C is a low-power RTC chip with temperature compensation function. It embeds a 32.768kHz XO. It supports calendar (year, month, day, hour, minute, second) function. The SOP8 package makes it suitable to be used in portable electronic devices.

# 2 Block Diagram

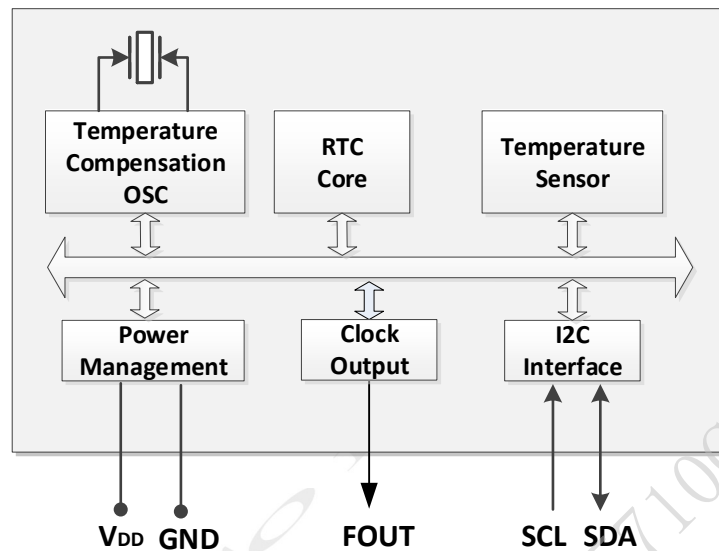

Figure 1. Block Diagram

# 3 Features

- Low Current Consumption: 1.0uA (Typ.)
- High Stability:  
±20ppm @ -20°C ~ +70°C
- Build-in XO: 32.768kHz
- Build-in Temperature Sensor
- Communication Interface: I<sup>2</sup>C bus
- Power Supply Voltage: 1.6V~5.5V
- Operation Temperature Range: -40°C ~ +85°C
- Leap Years Autocorrection
- Package: 4.9mm × 6.0mm × 1.6mm (SOP8)



## 4 Pin Definition

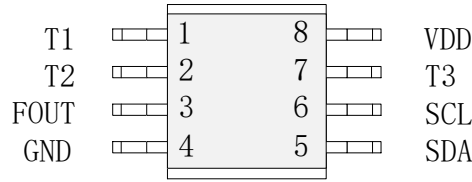

**Table1. Pin Definition**

Pin Number	Pin Name	I/O	Description
1	T1		Manufacturer test only. Ensure to be floating
2	T2		Manufacturer test only.
3	FOUT	Out	Frequency output Pin, configurable, CMOS.
4	GND	-	Ground
5	SDA	In/Out	I2C data signal
6	SCL	In	I2C clock signal
7	T3		Manufacturer test only. Ensure to be floating
8	V <sub>DD</sub>	-	Power in



## 5 Electrical Characteristics

### 5.1 Absolute Maximum Ratings

**Table2. Absolute Maximum Ratings**

Parameter	Symbol	Value			Unit	Notes
		Min.	Typ.	Max.		
Power Supply Voltage	V <sub>DD</sub>	-0.3		6.5	V	
I/O Input Voltage	V <sub>IN</sub>	GND-0.3		6.5	V	SCL, SDA Input
Clock Output Voltage1	V <sub>OUT1</sub>	GND-0.3		6.5	V	SDA Output
Storage temperature	T <sub>STG</sub>	-55		125	°C	

### 5.2 Recommended Operating Conditions

**Table3. Recommended Operating Conditions**

Parameter	Symbol	Value			Unit	Notes
		Min.	Typ.	Max.		
Power Supply Voltage (normal mode)	V <sub>DD</sub>	2.5	3.0	5.5	V	*
Power Supply Voltage (Time keeping)	V <sub>DD</sub>	1.6	3.0	5.5	V	*
Operation temperature	T <sub>OPR</sub>	-40	25	85	°C	

\*Note 1: During the power on and vibration starting time, a voltage of more than 2.5V must be provided to ensure the stable vibration starting of the oscillation circuit.

Note2: After the power supply is powered off, ensure that V<sub>DD</sub> = GND for more than 10 seconds, and then power on.

Note3: If there is no special indication, the test conditions are GND = 0V, V<sub>DD</sub> = 2.5V ~ 5.5V, T<sub>a</sub> = - 40 °C ~ + 85 °C

### 5.3 Frequency Characteristics

**Table4. Frequency Characteristics**

Parameter	Symbol	Value			Unit	Notes
		Min.	Typ.	Max.		
Frequency stability	Δf/f	±20			ppm	V <sub>DD</sub> =3.0V; @-20°C~+70°C
Oscillation start time	t <sub>STA</sub>			1	s	@25°C
Year Aging	f <sub>a</sub>			±3	ppm	First year@25°C

Note: If there is no special indication, the test conditions are GND = 0V, V<sub>DD</sub> = 2.5V ~ 5.5V, T<sub>a</sub> = - 40 °C ~ + 85 °C

### 5.4 DC Characteristics

**Table5. DC Characteristics**



参数	符号	数值			单位	备注	
		最小值	典型值	最大值			
Average Current1	IDD1		1.25	5.1	uA	VDD=5.0V	fSCL=0Hz, 输入信号为低。
Average Current2	IDD2		1.0	4.9		VDD=3.0V	
Input High Voltage	VIH	0.8*VDD		5.5	V	SCL, SDA 脚	
Input Low Voltage	VIL	GND-0.3		0.2*VDD	V		
Output Low Voltage	VOL1	GND		GND+0.5	V	VDD=5.0V, IOL = 1mA	FOUT 脚
	VOL2	GND		GND+0.8		VDD=3.0V, IOL = 1mA	
	VOL3	GND		GND+0.1		VDD=3.0V, IOL = 100uA	
	VOL4	GND		GND+0.4	V	VDD ≥ 3.0V, IOL = 3mA	SDA 脚
Output High Voltage	VOH1	4.0		5.0	V	VDD=5.0V, IOH = -1mA	FOUT 脚
	VOH2	2.2		3.0		VDD=3.0V, IOH = -1mA	
	VOH3	2.9		3.0		VDD=3.0V, IOH = -100uA	
Input Leak Current	ILK	-0.1		0.1	uA	SDA, SCL 脚, VIN = VDD 或 GND	
Output Leak Current	IOZ	-0.1		0.1	uA	SDA 脚, VIN = VDD 或 GND	

Note3: If there is no special indication, the test conditions are GND = 0V, VDD = 2.5V ~ 5.5V, Ta = - 40 °C ~ + 85 °C

## 5.5 AC Characteristics

**Table6. AC Characteristics**

V<sub>DD</sub>=2.5V ~ 5.5V; Ta=-40°C ~ +85°C

Parameter	Symbol	Value			Unit
		Min.	Typ.	Max.	
SCL clock frequency	f <sub>SCL</sub>			400	kHz
SCL Low Voltage Time	t <sub>LOW</sub>	1.3			us
SCL How Voltage Time	t <sub>HIGH</sub>	0.6			us
Start condition hold time	t <sub>HD, STA</sub>	0.6			us
Start condition setup time	t <sub>SU, STA</sub>	0.6			us





Parameter	Symbol	Value			Unit
		Min.	Typ.	Max.	
Stop condition setup time	$t_{SU, STO}$	0.6			us
Bus idle time between start condition and stop condition	$t_{RCV}$	1.3			us
Data setup time	$t_{SU, DAT}$	100			ns
Data hold time	$t_{HD, DAT}$	0			ns
SCL, SDA rising time	$t_r$			0.4	us
SCL, SDA falling time	$t_f$			0.4	us

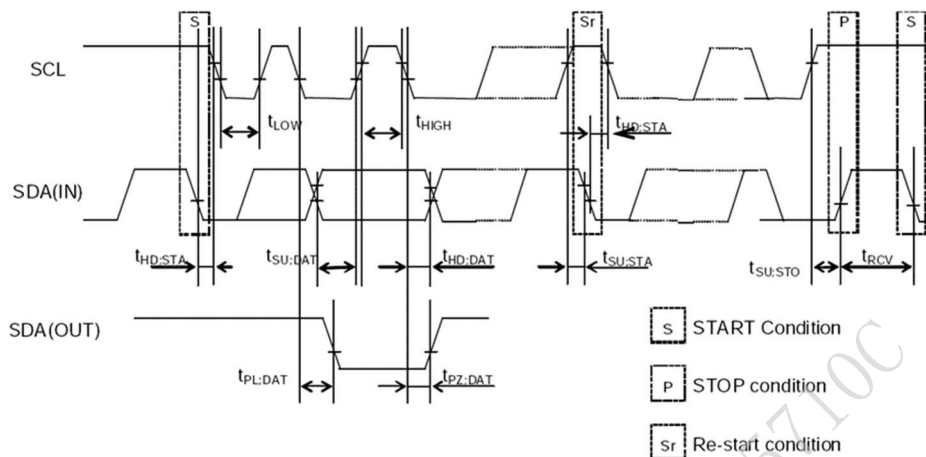

Figure 2. I<sup>2</sup>C bus Timing Chart

Note: When the master device gets access to this slave device through I2C, the whole operation duration should be less than 1s, otherwise it will be reset by the I2C bus through the internal bus overtime function.



# 6 Register

## 6.1 Register list

Address 0x00~0x0F: Basic Time and Calendar Registers

Address 0x10~0x1F: Extended Register Group 1

Address 0x20~30: Extended Register Group 2

Note: 0x10~16 and 0x00~06 with the same function, 0x1B~1F and 0x0B~0F with the same function

**Table7. Basic Time and Calendar Registers**

Address	Function	bit7	bit6	bit5	bit4	bit3	bit2	bit1	bit0	R/W
0x00	SEC	○	BCD code, Second tens place, 0-5			BCD code, Second ones place, 0-9				R/W
0x01	MIN	○	BCD code, Minute tens place, 0-5			BCD code, Minute ones place, 0-9				R/W
0x02	HOUR	○	○	BCD code, Hour tens place, 0-2		BCD code, Hour ones place, 0-9				R/W
0x03	WEEK	○	6	5	4	3	2	1	0	R/W
0x04	DAY	○	○	BCD code, Day tens place, 0-3		BCD code, Day ones place, 0-9				R/W
0x05	MONTH	○	○	○	BCD code, Month tens place, 0-1	BCD code, Month ones place, 0-9				R/W
0x06	YEAR	BCD code, Year tens place, 0-9				BCD code, Year ones place, 0-9				R/W
0x07	RAM	●	●	●	●	●	●	●	●	R/W
0x08	RSV	Reserved								R
0x09	RSV	Reserved								R
0x0A	RSV	Reserved								R
0x0B	RSV	Reserved								R
0x0C	RSV	Reserved								R
0x0D	Extension Register	TEST	Reserved	Reserved	Reserved	FSEL[1]	FSEL[0]	Reserved	Reserved	R/W
0x0E	Flag Register	○	○	Reserved			○	VLF	Reserved	R/W
0x0F	Control Register	Reserved					○	○	RESET	R/W

**Table8. Extended Register Group 1**

Address	Function	bit7	bit6	bit5	bit4	bit3	bit2	bit1	bit0	R/W
0x10	SEC	○	BCD code, Second tens place, 0-5			BCD code, Second ones place, 0-9				R/W
0x11	MIN	○	BCD code, Minute tens place, 0-5			BCD code, Minute ones place, 0-9				R/W
0x12	HOUR	○	○	BCD code, Hour tens place, 0-2		BCD code, Hour ones place, 0-9				R/W
0x13	WEEK	○	6	5	4	3	2	1	0	R/W
0x14	DAY	○	○	BCD code, Day tens place, 0-3		BCD code, Day ones place, 0-9				R/W



Address	Function	bit7	bit6	bit5	bit4	bit3	bit2	bit1	bit0	R/W
0x15	MONTH	○	○	○	BCD code, Month tens place, 0-1	BCD code, Month ones place, 0-9				R/W
0x16	YEAR	BCD code, Year tens place, 0-9				BCD code, Year ones place, 0-9				R/W
0x17	TEMP	128	64	32	16	8	4	2	1	R
0x18	RSV	○	○	○	○	Reserved	●	●	●	R/W
0x19	Not use	○	○	○	○	○	○	○	○	R
0x1A	Not use	○	○	○	○	○	○	○	○	R
0x1B	RSV	Reserved								R/W
0x1C	RSV	Reserved								R/W
0x1D	Extension Register	TEST	Reserved	Reserved	Reserved	FSEL[1]	FSEL[0]	Reserved	Reserved	R/W
0x1E	Flag Register	○	○	Reserved			○	VLF	Reserved	R/W
0x1F	Control Register	Reserved					○	○	RESET	R/W

**Table9. Extended Register Group2**

Address	Function	bit7	bit6	bit5	bit4	bit3	bit2	bit1	bit0	R/W	
0x20	Device ID	Vendor ID[3:0]				Ver[3:0]				R	
0x21	Control Register 1	Reserved: Ensure to be 0x8					○	○	○	●	R/W
0x22-26	RSV	Reserved: Ensure to be 0x00								R	
0x27	SubSEC	Reserved				SubSEC[3:0]				R	
0x28	Extension Register	FOE [1]	FOE [0]	保留位	保留位	保留位	保留位	保留位	保留位	R/W	
0x29-30	RSV	Reserved: Ensure to be 0x00								R/W	

Note:

1, After power-up reset or in case VLF bit returns “1”, make sure to initialize all registers to default state before using the RTC. Ensure all inputs are in the required range and the defined values are set for the reserved bits in case the clock cannot work normally.

- ✓ During the initial power-up, below bits will be in the state as below:
  - Initial 0: TEST, RESET.
  - Initial 1: VLF
- ✓ All other register values are undefined, so make sure to reset the module before using it.
- ✓ The bits marked with “○” can be read out “0” only after initializing.
- ✓ The bits marked with “●” are RAM bits which can be used to write or read any data.
- ✓ Only 0 can be written to VLF bits.
- ✓ Make sure “0” to be written for TEST bits which are used for testing only.
- ✓ Reserved bits must be set to the defined values accordingly.



## 6.2 Details of Registers

### 6.2.1 Clock counter registers

Address	Function	bit7	bit6	bit5	bit4	bit3	bit2	bit1	bit0	Default
0x00/10	SEC	○	BCD code, Second tens place, 0-5			BCD code, Second ones place, 0-9				0x00
0x01/11	MIN	○	BCD code, Minute tens place, 0-5			BCD code, Minute ones place, 0-9				0x00
0x02/12	HOUR	○	○	BCD code, Hour tens place, 0-2		BCD code, Hour ones place, 0-9				0x00

SEC: BCD format, Value: 0~59

MIN: BCD format, Value: 0~59

HOUR: BCD format, Value: 0~23

Address	Function	bit7	bit6	bit5	bit4	bit3	bit2	bit1	bit0	Default
0x03/13	WEEK	○	6	5	4	3	2	1	0	0x40

WEEK: Value 01h, 02h, 04h, 08h, 10h, 20h, 40h. Only one bit can be set to 1 each time, all others must be set to 0.

**Table10. WEEK Register**

WEEK	Data	bit7	bit6	bit5	bit4	bit3	bit2	bit1	bit0
Sunday	01h	0	0	0	0	0	0	0	1
Monday	02h	0	0	0	0	0	0	1	0
Tuesday	04h	0	0	0	0	0	1	0	0
Wednesday	08h	0	0	0	0	1	0	0	0
Thursday	10h	0	0	0	1	0	0	0	0
Friday	20h	0	0	1	0	0	0	0	0
Saturday	40h	0	1	0	0	0	0	0	0

Address	Function	bit7	bit6	bit5	bit4	bit3	bit2	bit1	bit0	Default
0x04/14	DAY	○	○	BCD code, Day tens place, 0-3		BCD code, Day ones place, 0-9				0x01

DAY: BCD format, the value range will be adjusted automatically according to the month setting and if a leap year or not .

**Table11. DAY Register Value**

Month	Day Value Range
1, 3, 5, 7, 8, 10, 12	1~31
4, 6, 9, 11	1~30
February in normal year	1~28
February in leap year	1~29



Address	Function	bit7	bit6	bit5	bit4	bit3	bit2	bit1	bit0	Default
0x05/15	MONTH	○	○	○	BCD code, Month tens place, 0-1	BCD code, Month ones place, 0-9			0x01	
0x06/16	YEAR	BCD code, Year tens place, 0-9				BCD code, Year ones place, 0-9				0x00

MONTH: BCD format, Value1~12

YEAR: BCD format, Value0~99(2000~2099)

Example: 2020/01/01 Wednesday 21:18:36

Address	Function	bit7	bit6	bit5	bit4	bit3	bit2	bit1	bit0
0x00/10	SEC	○	0	1	1	0	1	1	0
0x01/11	MIN	○	0	0	1	1	0	0	0
0x02/12	HOURL	○	○	1	0	0	0	0	1
0x03/13	WEEK	○	0	0	0	1	0	0	0
0x04/14	DAY	○	○	0	0	0	0	0	1
0x05/15	MONTH	○	○	○	0	0	0	0	1
0x06/16	YEAR	0	0	1	0	0	0	0	0

### 6.2.2 Extension registers

Address	Function	bit7	bit6	bit5	bit4	bit3	bit2	bit1	bit0	Default
0x0D/1D	Extension Register	TEST	Reserved	Reserved	Reserved	FSEL[1]	FSEL[0]	Reserved	Reserved	0x02

TEST: Test bit, must be set to “0”

FSEL[1], FSEL[0]: FOUT select

FSEL [1]	FSEL [0]	FOUT
0	0	32768Hz (default)
0	1	1024Hz
1	0	1Hz
1	1	32768

### 6.2.3 Flag registers

Address	Function	bit7	bit6	bit5	bit4	bit3	bit2	bit1	bit0	Default
0x0E/1E	Flag Register	○	○	Reserved			○	VLF	Reserved	0x03

VLF: Voltage Low Flag bit. When supply voltage is lower than 1.6V, it will be set to “1” and keeps “1” until a “0” is written to it.

### 6.2.4 Control registers

Address	Function	bit7	bit6	bit5	bit4	bit3	bit2	bit1	bit0	Default
0x0F/1F	Control Register	Reserved					○	○	RESET	0x40

RESET: Reset IC, prepared for the synchronized starting of time.



### 6.2.5 Temperature register

Address	Function	bit7	bit6	bit5	bit4	bit3	bit2	bit1	bit0	Default
0x17	TEMP	128	64	32	16	8	4	2	1	0x00

Read digital temperature data, Temp [°C] = (TEMP[7:0] \* 2 -187.19) / 3.218.

### 6.2.6 RSV register

Address	Function	bit7	bit6	bit5	bit4	bit3	bit2	bit1	bit0	Default
0x18	Reserved	○	○	○	○	Reserved	●	●	●	0x00

Bit3 is the reserved bit, suggest being clear to '0'.

### 6.2.7 Device ID register

Address	Function	bit7	bit6	bit5	bit4	bit3	bit2	bit1	bit0	Default
0x20	Device ID	VendorID[3:0]				Ver[3:0]				0xd2

VendorID[3:0]: The fixed value is defined as VendorID[3:0]=1101b=Dh to represent DAPU.

Ver[3:0]: version of the IC

### 6.2.8 Control Register 1

Address	Function	bit7	bit6	bit5	bit4	bit3	bit2	bit1	bit0	Default
0x21	Control Register 1	Reserved: must be 0x8				○	○	○	●	0x80

### 6.2.9 Sub-second timer register

Address	Function	bit7	bit6	bit5	bit4	bit3	bit2	bit1	bit0	Default
0x27	SubSEC	Reserved				SubSEC[3:0]				0x00

SubSEC[3:0]: sub second bit, and unit is 1/16s.

### 6.2.10 Extension Register

Address	Function	bit7	bit6	bit5	bit4	bit3	bit2	bit1	bit0	Default
0x28	Extension Register	FOE [1]	FOE [0]	Reserved	Reserved	Reserved	Reserved	Reserved	Reserved	0x00

FOE[1], FOE[0]: FOUT Enable:

FOE [1]	FOE [0]	FOUT
1	1	FOUT Enable
0	0	FOUT Disable (Default)
1	0	-
0	1	-



## 7 I<sup>2</sup>C Bus Interface

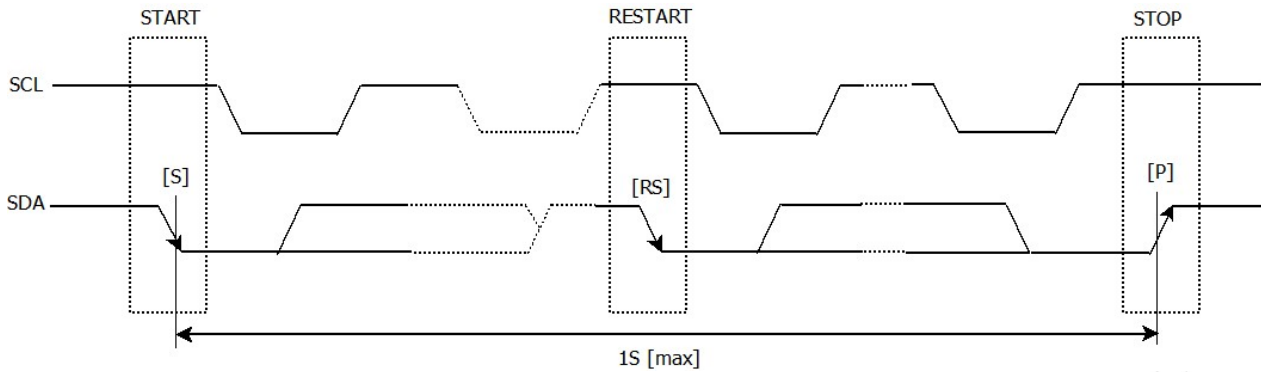

I<sup>2</sup>C bus supports bi-directional communications through a serial clock line SCL and a serial data line SDA. I<sup>2</sup>C bus device can be defined as “Master” and “Slave”. INS5710C can only be used as Slave.

### 7.1 Cautions

I<sup>2</sup>C bus includes START, RESTART, STOP conditions, the duration between START and STOP must be less than 1 second just in case the bus to be set to standby mode automatically. If the time is more than 1S, INS5710C will reset I<sup>2</sup>C Interface.

INS5710C I<sup>2</sup>C bus interface supports single byte read/write operations as well as multiple bytes incremental access. After 0xFF address, the next one will be 0x00.

### 7.2 Slave Address

Table12. I<sup>2</sup>C Bus Slave Address

Transfer data	Slave address							R/W
	bit7	bit6	bit5	bit4	bit3	bit2	bit1	bit0
65h (Read)	0	1	1	0	0	1	0	1 (Read)
64h (Write)	0	1	1	0	0	1	0	0 (Write)

INS5710C I<sup>2</sup>C bus Slave Address is [0110 010\*].

### 7.3 I<sup>2</sup>C bus protocol

It is assumed CPU is master and INS5710C is slave in this section.

#### 7.3.1 Write process

I<sup>2</sup>C bus includes an address auto-increment function, once the initial address has been specified, the INS5710A increments (+1) the address automatically after each data is sent, then to write next data.



- (1) CPU sends start condition[S]
- (2) CPU sends INS5710C's slave address with R/W bit to set to write mode
- (3) CPU verifies ACK signal from INS5710C
- (4) CPU sends write address to INS5710C
- (5) CPU verifies ACK signal from INS5710C
- (6) CPU sends write data to the address specified at step (4)
- (7) CPU verifies ACK signal from INS5710C
- (8) Repeat (6) (7) if multiple bytes need to be written, address will be incremented automatically
- (9) CPU ends stop condition[P]

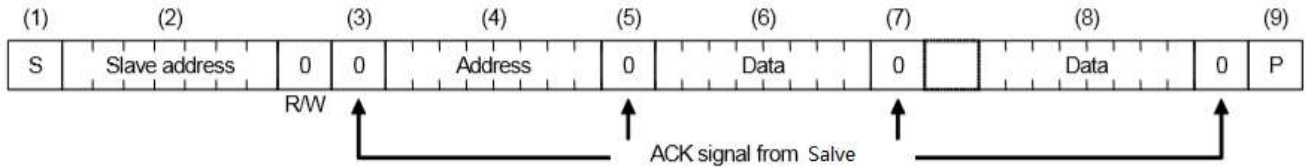

### 7.3.2 Read process

Writing the address to be read with write mode firstly, then reading the data with read mode.

- (1) CPU sends start condition[S]
- (2) CPU sends INS5710C's slave address with R/W bit to set to write mode
- (3) CPU verifies ACK signal from INS5710C
- (4) CPU sends address for reading from INS5710C
- (5) CPU verifies ACK signal from INS5710C
- (6) CPU sends RESTART condition [Sr]
- (7) CPU sends INS5710C's slave address with R/W bit to set to read mode
- (8) CPU verifies ACK signal from INS5710C
- (9) CPU reads data from the specified address in step (4)
- (10) CPU sends ACK signal for "0"
- (11) Repeat (9) (10) if multiple bytes need to be read, address will be incremented automatically
- (12) CPU sends ACK signal for "1"
- (13) CPU sends stop condition[P]

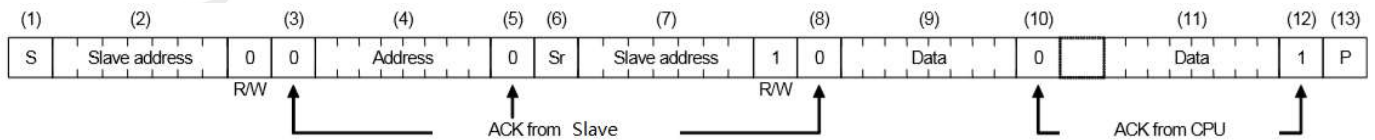





# 8 Reflow Soldering Curve

Standard: IPC/JEDEC J-STD-020

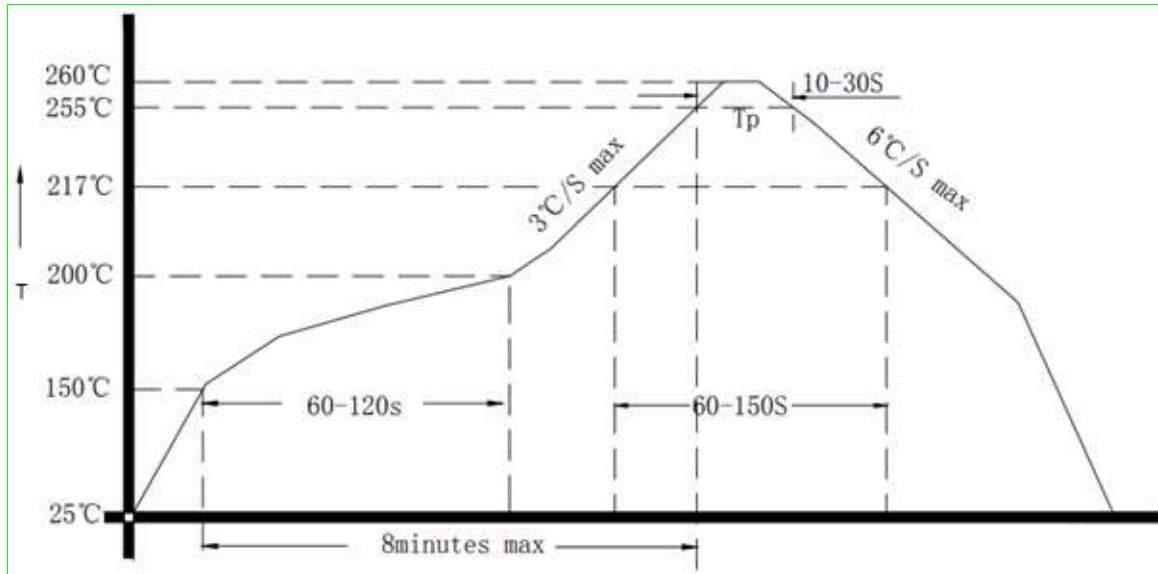

Figure 3. Reflow Soldering Curve

Note: It is suggested to solder IC under the condition shown in the curve above. Must pay attention to the temperature and time when manual soldering, if the temperature over +260°C, or you will make the xo performance bad, even damage it.



# 9 Dimensions

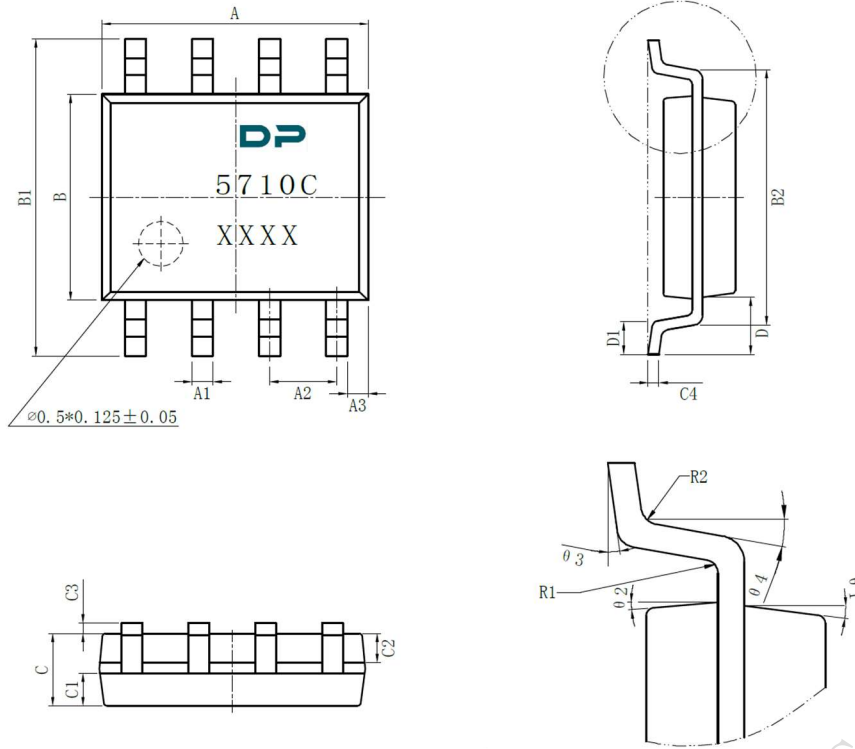

Figure 4. Dimension

Dimension	Min.	Typ.	Max.
A	4.8	4.9	5.0
A1	0.356	--	0.456
A2	--	1.27	--
A3	--	0.345	--
B	3.8	3.9	4.0
B1	5.8	6.0	6.2
B2	--	5.00	--
C	1.3	--	1.6
C1	0.55	--	0.65
C2	0.55	--	0.65

(Unit: mm)

Dimension	Min.	Typ.	Max.
C3	0.05	--	0.20
C4	0.203	--	0.233
D	--	1.05	--
D1	0.4	--	0.8
R1	--	0.2	--
R2	--	0.2	--
$\theta 1$	17°		
$\theta 2$	13°		
$\theta 3$	0°~8°		
$\theta 4$	4°~12°		

(Unit: mm)



# 10 Package Information

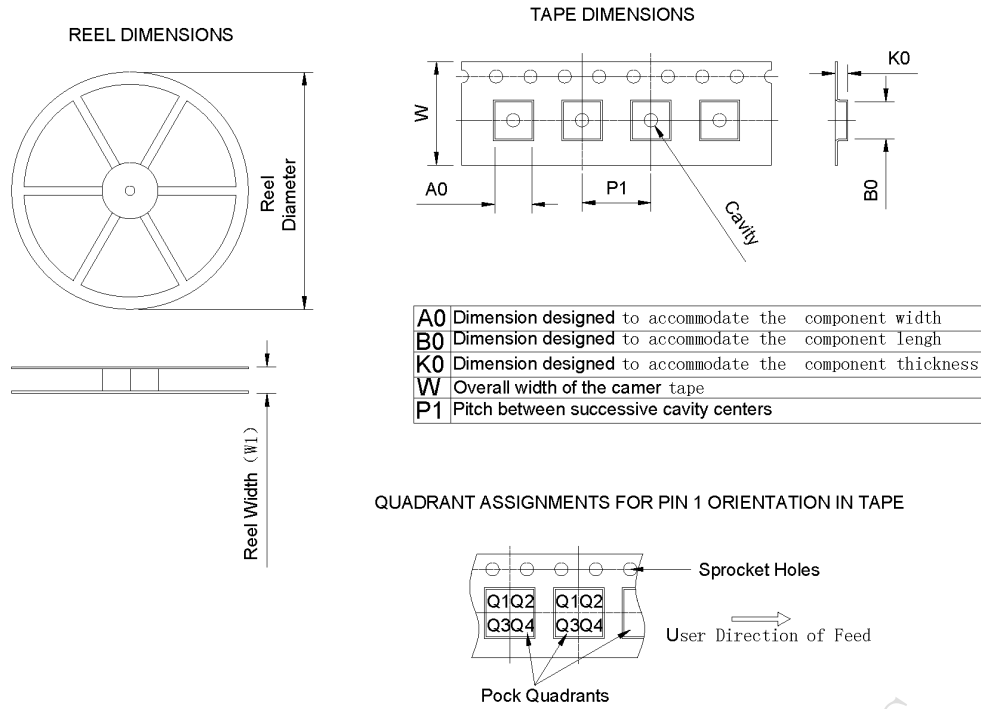

Device	Package Type	Pins	SPQ	Reel Diameter (mm)	Reel Width W1(mm)	A0 (mm)	B0 (mm)	K0 (mm)	P1 (mm)	W (mm)	PIN1 Quadrant
INS5710C	SOP	8	3000	330±1	12.4±0.2	6.40	5.30	2.10	8.00±0.1	12.00±0.1	Q1

Figure 5. Package information