

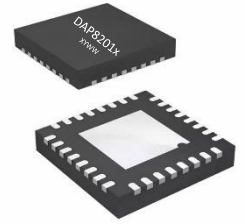

DAP8201M(I) —A Fast Ethernet PHY Series



Overview

The DAP8201M(I) is a single port Ethernet PHY, which has the characteristics of robustness, low power consumption and all physical layer functions. At the same time, it supports 10Base-Te, and 100Base TX, suitable for applications in security, communication and other electronic fields.

This device directly connects to the MAC layer through MII or RMI and supports MII/RMII to Copper.

The DAP8201M(I) is designed for easy implementation of 10/100Mbps Ethernet LANs. The MDI ports interfaces directly to CAT5 twisted pair media cable through the external transformer.

The DAP8201M(I) supports single 3.3V power supply.

Designed for low power, Wake-on-LAN can be used to lower system power consumption. The DAP8201M(I) is suitable for a wide range of applications.

Block Diagram

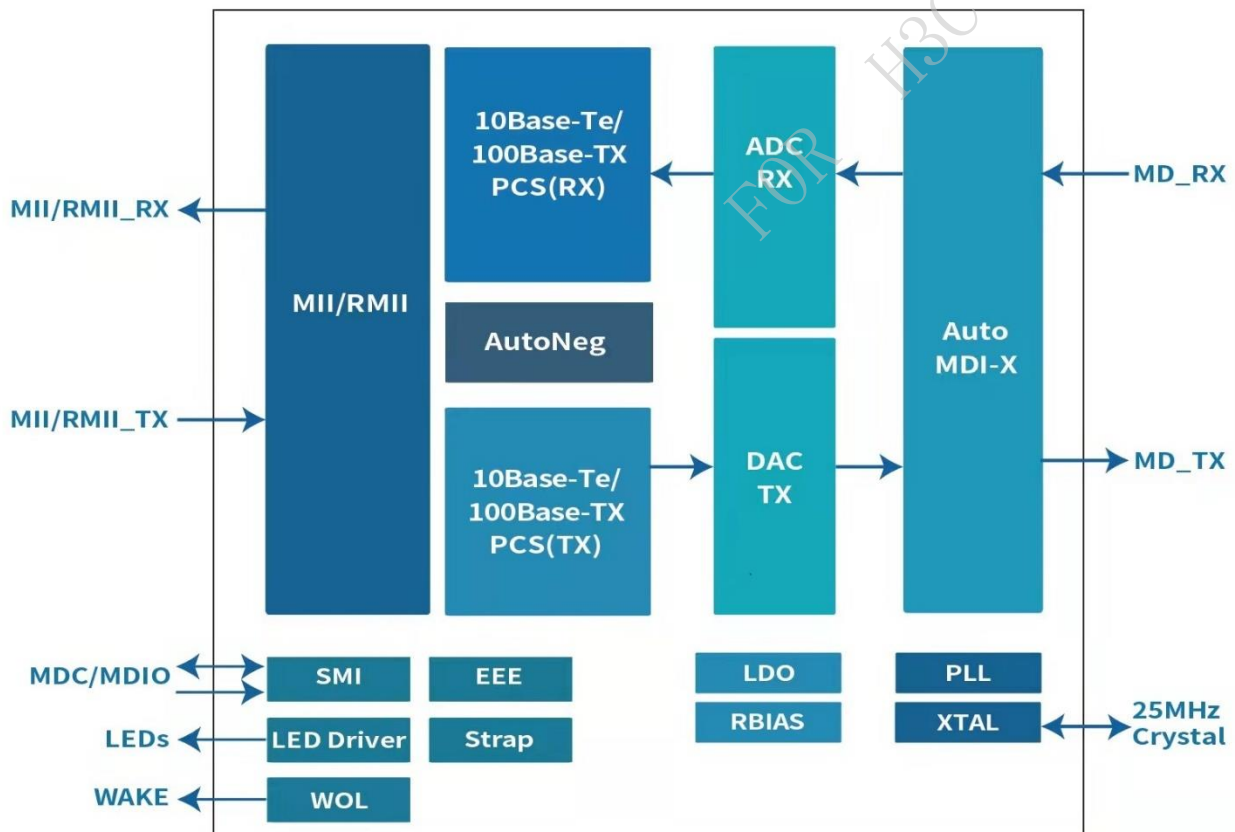



Key Features

- MII and RMI MAC Interface Options
- MII to Copper, RMII to Copper
- 100Base-TX/10Base-Te IEEE 802.3 Compliant
- IEEE 802.3az-2010 (EEE) Compliant
- WoL (Wake-on-LAN)
- Power Down Mode
- Auto-negotiation
- Auto-MDI-X
- Automatic Polarity Correction
- Supports Base Line Wander Correction
- Supports Interrupt Function
- 2 LEDs for Network Status
- Supports 25MHz External Crystal or 25M OSC Clock Input
- Output 50MHz Clock For MAC
- Integrate Linear Regulator 1.2V
- MAC I/O Voltage :3.3V
- 3.3V Single Power Supply
- Operation Temperature Range:
 - 0°C ~ +70°C
 - 40°C ~ +85°C
- Package: QFN 32-pin 5mm x 5mm

Part Number	MI I to Copper	RMII to Copper	WoL	100Base-TX	10Base-Te	EEE	Integrated LDO	Temp.	Package
DAP8201M	●	●	●	●	●	●	●	0°C ~ +70°C	QFN32
DAP8201MI	●	●	●	●	●	●	●	-40°C ~ +85°C	QFN32

●: Support

Applications

- Enterprise & SOHO
- LED Display
- Industrial Embedded Computing
- Wired and Wireless Communications Infrastructure
- Consumer Electronics

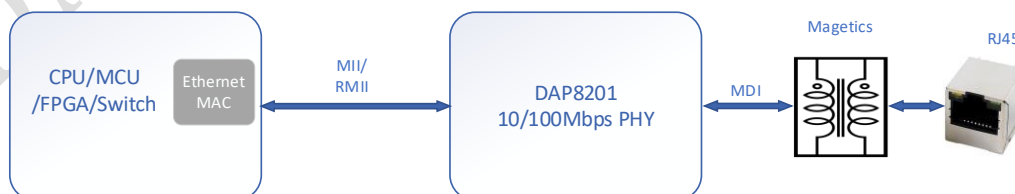



Index

OVERVIEW	1
BLOCK DIAGRAM.....	1
KEY FEATURES	2
REVISION HISTORY	3
INDEX	4
1 PIN DEFINITION	8
2 ELECTRICAL CHARACTERISTICS	11
2.1 ABSOLUTE MAXIMUM RATINGS	11
2.2 RECOMMENDED OPERATING CONDITIONS	11
2.3 POWER CONSUMPTION.....	13
2.4 DC CHARACTERISTICS	13
2.5 TIMING CHARACTERISTICS	13
2.5.1 Reset Timing	13
2.5.2 MII Interface Timing	14
2.5.3 RMII Interface Timing	16
2.6 REFERENCE CLOCK REQUIREMENTS	17
3 DETAIL DESCRIPTION	18
3.1 BLOCK DIAGRAM	18
3.2 FEATURE DESCRIPTION	18
3.2.1 WoL (Wake-on-LAN)	18
3.2.2 Auto-Negotiation.....	19
3.2.3 Auto-MDIX.....	20
3.2.4 Automatic Polarity Correction	20
3.2.5 IEEE 802.3az-2010 EEE	20
3.2.6 UTP Ethernet	20
3.2.7 MII Interface	20



3.2.8	RMII Interface.....	21
3.2.9	Reverse MII Interface.....	22
3.2.10	Loopback Mode.....	22
3.2.11	Hardware Bootstrap Configuration.....	23
3.2.12	Reset.....	23
3.2.13	Power Supply.....	23
4	REGISTERS.....	25
4.1	REGISTER MAPPING.....	25
4.2	REGISTER ACCESS TYPES.....	25
4.3	BASIC REGISTER.....	25
4.3.1	BMCR(Basic Mode Control Register , Address: Register 0x0).....	26
4.3.2	BMSR (Basic Mode Status Register , Address: Register 0x1).....	27
4.3.3	PHYID1 (PHY Identifier Register #1 , Address: Register 0x2).....	28
4.3.4	PHYID2 (PHY Identifier Register #2 , Address: Register 0x3).....	28
4.3.5	ANAR (Auto-Negotiation Advertising , Address: Register 0x4).....	28
4.3.6	ANLPA (Auto-Negotiation Link Partner Ability, Address: Register 0x5).....	29
4.3.7	ANE (Auto-Negotiation Expansion Register Address: Register 0x6).....	30
4.3.8	ANNPT (Auto-Negotiation Next Page Transmit Register Address: Register 7).....	30
4.3.9	ANNPR (Auto-Negotiation Next Page Received Register Address: Register 0x8).....	31
4.3.10	MSSR (Master-Slave Status Register Address: Register 0xA).....	31
4.3.11	MMD_AC (MMD Access Control; Address: Register 0xD).....	32
4.3.12	MMD_AADA (MMD Access Address Data, Address: Register 0xE).....	32
4.3.13	PHYCR (PHY Control Register, Address: Register 0x10).....	32
4.3.14	PHYSR (PHY Status Register, Address: Register 0x11).....	33
4.3.15	INTCR (Interrupt Control Register, Address: Register 0x12).....	34
4.3.16	INTSR (Interrupt Status Register, Address: Register 0x13).....	35
4.3.17	SPCR (Speed Configuration Register, Address: Register 0x14).....	35
4.3.18	RECR (Receiver Error Counter Register, Address: Register 0x15).....	36



4.3.19	EXT_ADD (Extended Register Address Register, Address: Register 0x1E)	36
4.3.20	EXT_DATA (Extended Register Data Register, Register 0x1F).....	36
4.4	EXTENDED REGISTER	36
4.4.1	EXT_10M_PWRCON (10Mbps Power Control Register, Address: Register 0x200A)	36
4.4.2	EXT_COMBO_CON (COMBO Control Register, Address: Register 0x4000)	36
4.4.3	EXT_PIN_CON (PAD Control Register, Address: Register 0x4001).....	37
4.4.4	EXT_COMBO2_CON (COMBO2 Control Register, Address: Register 0x4003)	37
4.4.5	WoL_MAC_ADDH(WoL MAC Highest Address Register, Address: Register 0x4004).....	38
4.4.6	WoL_MAC_ADDM(WoL MAC Middle Address Register, Address: Register 0x4005).....	38
4.4.7	WoL_MAC_ADDL(WoL MAC Lowest Address Register, Address: Register 0x4006)	38
4.4.8	PKG_ST_CON (Package Generation Selftest Control, Address: Register 0x40A0).....	38
4.4.9	PKG_LEN(Package Generation Length, Address: Register 0x40A1)	39
4.4.10	PKG_BS(Package Generation Burst Size, Address: Register 0x40A2).....	39
4.4.11	PKG_RV_H(Package Receiver Valid High, Address: Register 0x40A3).....	39
4.4.12	PKG_RV_L(Package Receiver Valid Low, Address: Register 0x40A4).....	40
4.4.13	PKG_RX_OSH(Package Receiver OS High, Address: Register 0x40A5).....	40
4.4.14	PKG_RX_OSL(Package Receiver OS Low, Address: Register 0x40A6).....	40
4.4.15	PKG_RX_USH(Package Receiver US High, Address: Register 0x40A7)	40
4.4.16	PKG_RX_USL(Package Receiver US Low, Address: Register 0x40A8).....	40
4.4.17	PKG_RX_ERR(Package Receiver Error, Address: Register 0x40A9).....	40
4.4.18	PKG_RX_OS_ERR(Package Receiver OS Error, Address: Register 0x40AA).....	41
4.4.19	PKG_RX_FRM (Package Receiver Fragment, Address: Register 0x40AB).....	41
4.4.20	PKG_RX_NOSFD (Package Receiver NOSFD, Address: Register 0x40AC).....	41
4.4.21	PKG_TV_H(Package Transmit Valid High, Address: Register 0x40AD).....	41
4.4.22	PKG_TV_L(Package Transmit Valid Low, Address: Register 0x40AE)	41
4.4.23	PKG_TX_OSH(Package Transmit OS High, Address: Register 0x40AF).....	41
4.4.24	PKG_TX_OSL(Package Transmit OS Low, Address: Register 0x40B0).....	42
4.4.25	PKG_TX_USH(Package Transmit US High, Address: Register 0x40B1).....	42



4.4.26	PKG_TX_USL(Package Transmit US Low, Address: Register 0x40B2).....	42
4.4.27	PKG_TX_ERR(Package Transmit Error, Address: Register 0x40B3)	42
4.4.28	PKG_TX_OS_ERR(Package Transmit OS Error, Address: Register 0x40B4).....	42
4.4.29	PKG_TX_FRM (Package Transmit Fragment, Address: Register 0x40B5)	42
4.4.30	PKG_TX_NOSFD (Package Transmit NOSFD, Address: Register 0x40B6)	43
4.4.31	PKG_CON2 (Package Generation Configure2, Address: Register 0x40B7).....	43
4.4.32	PKG_CON3 (Package Generation Configure3, Address: Register 0x40B8).....	43
4.4.33	PKG_CON4 (Package Generation Configure4, Address: Register 0x40B9).....	43
4.4.34	PKG_CON5 (Package Generation Configure5, Address: Register 0x40BA)	43
4.4.35	LED0_CON (LED0 Control Register, Address: Register 0x40C0).....	44
4.4.36	LED_COMCON (LED Common Control Register, Address: Register 0x40C1)	44
4.4.37	LED_BLCON (LED Blink Control Register, Address: Register 0x40C2)	45
4.4.38	LED1_CON (LED1 Control Register, Address: Register 0x40C3).....	46
5	ENVIRONMENT	47
6	DIMENSIONS	48



1 Pin Definition

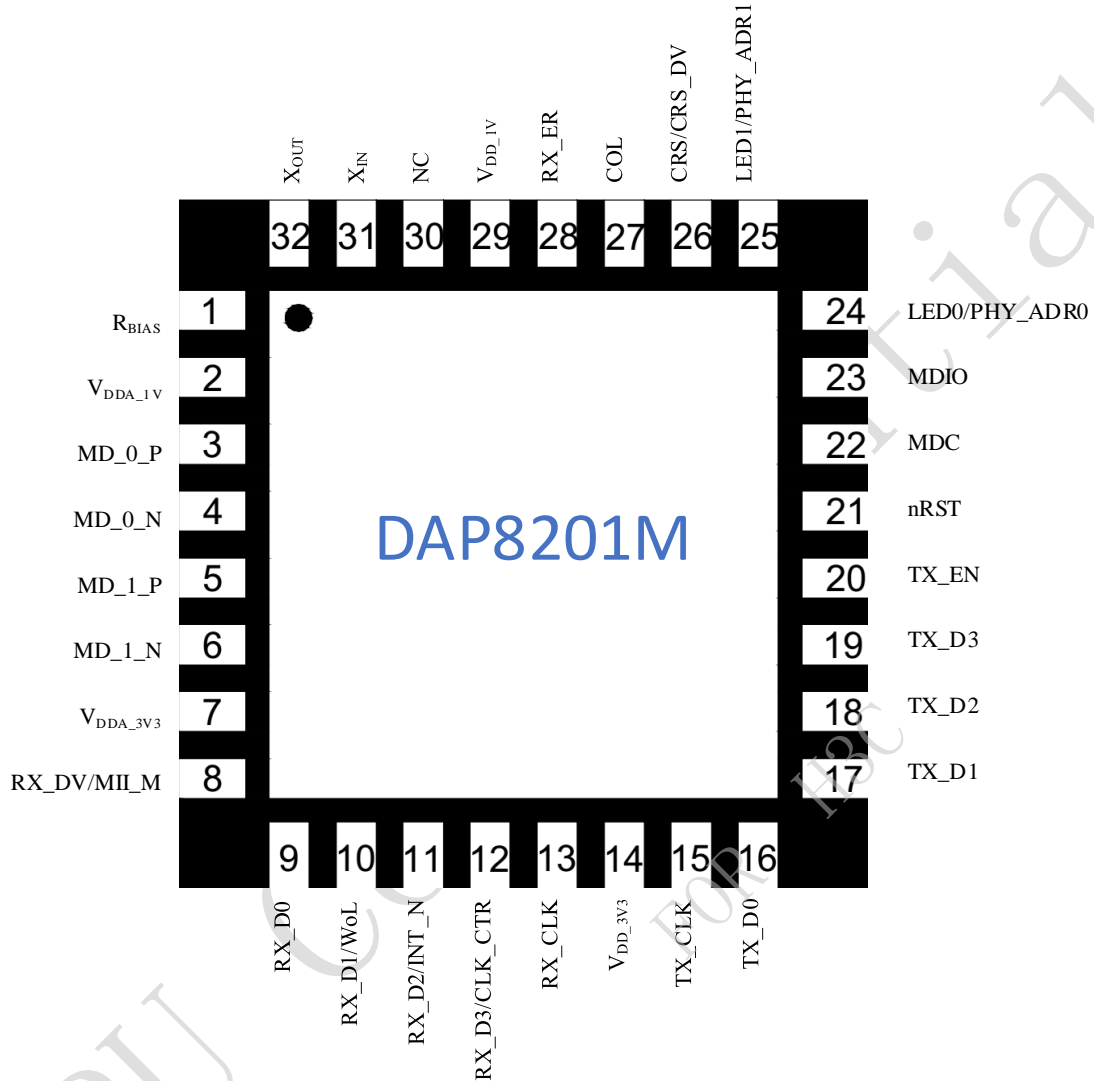

Figure 1 Package 32-Pin (Top View)

Table1. Pin Definition

Pin Number	Pin Name	I/O	Description
POWER AND GROUND			
2	V _{DDA_1V}	PWR/O	Power Output. Be sure to connect a 0.1μF and a 1.0uF ceramic capacitors for decoupling purposes.
7	V _{DDA_3V3}	PWR	3.3V Analog Supply Input. A 1μF and 0.1μF capacitor are required to GND.
14	V _{DD_3V3}	PWR	3.3V Digital Supply Input. Digital I/O power input for MII/RMII I/O, MDC/MDIO



29	V _{DD_1V}	PWR/O	Power Output. Be sure to connect a 0.1μF and a 1.0uF ceramic capacitors for decoupling purposes.
33	EPAD	GND	Ground
REFERENCE CLOCK			
31	X _{IN}	I	Crystal/Oscillator Input: 25MHz oscillator or 25MHz crystal input
32	X _{OUT}	O	Crystal Output: 25MHz crystal. Must be left floating if use oscillator.
MEDIA DEPENDENT INTERFACE			
3	MD_0_P	I/O	Differential Transmit/Receive. These differential IOs are automatically configured to either 10Base-Te or 100Base-TX signaling. Auto-MDIX mode: it can be used as the Receive Input pair. There are 50Ω internal terminations on each pin, and due to this device incorporates voltage driven DAC, it does not require a center-tap power supply.
4	MD_0_N	I/O	
5	MD_1_P	I/O	Differential Transmit/Receive. These differential IOs are automatically configured to either 10Base-Te or 100Base-TX signaling. Auto-MDIX mode: it can be used as the Receive Input pair. There are 50Ω internal terminations on each pin, and due to this device incorporates voltage driven DAC, it does not require a center-tap power supply.
6	MD_1_N	I/O	
MANAGEMENT INTERFACE			
21	nRST	I/HZ	Reset: The active low RESET initializes or reinitializes the PHY, then all internal registers reinitialize to the default state. Note: The reset signal must be held low at least 10ms.
22	MDC	I/PU	Management Data Clock
23	MDIO	I/O/PU	Input/Output of Management Data.
MII/RMII Interface			
15	TX_CLK	I/O/PD	MII Mode: MII transmit clock, MII transmit clock provides a 25MHz reference clock for 100Mbps and a 2.5MHz reference clock for 10Mbps. RMII Mode: RMII Reference Clock, 50MHz input or output for both transmit and receive. The default direction is reference clock output mode if RX_D3/CLK_CTR pin floating.
20	TX_EN	I/PD	Transmit enable: TX_EN is presented on the rising edge of the TX_CLK. MII Mode: TX_EN indicates the presence of valid data inputs on TX_D[3:0] RMII Mode: TX_EN indicates the presence of valid data inputs on TX_D[1:0] TX_EN is an active high signal.
16	TX_D0	I/PD	Transmit Data. The MAC will source TXD [0:3] synchronous with TXC when TX_EN is asserted.
17	TX_D1	I/PD	
18	TX_D2	I/PD	
19	TX_D3	I/PD	



13	RX_CLK	O/PD	Receive clock: Receive Clock provides a 25MHz reference clock for 100Mbps speed and a 2.5MHz reference clock for 10Mbps speed, which is derived from the received data stream.															
8	RX_DV/MII_M	O/LI/PD	<p>Receive data valid: This pin indicates valid data is present on the RX_D[3:0] for MII mode.</p> <p>Hardware Bootstrap for Media Mode Select with Pin13, 0: MII 1: RMII</p> <table border="1"> <thead> <tr> <th>Pin8</th> <th>Pin12</th> <th>Media Mode</th> </tr> </thead> <tbody> <tr> <td>0</td> <td>0</td> <td>MII</td> </tr> <tr> <td>0</td> <td>1</td> <td>Reverse MII</td> </tr> <tr> <td>1</td> <td>0</td> <td>RMII2(TX_CLK outputs 50MHz Reference clock by default)</td> </tr> <tr> <td>1</td> <td>1</td> <td>RMII1(TX_CLK inputs 50MHz Reference clock)</td> </tr> </tbody> </table>	Pin8	Pin12	Media Mode	0	0	MII	0	1	Reverse MII	1	0	RMII2(TX_CLK outputs 50MHz Reference clock by default)	1	1	RMII1(TX_CLK inputs 50MHz Reference clock)
Pin8	Pin12	Media Mode																
0	0	MII																
0	1	Reverse MII																
1	0	RMII2(TX_CLK outputs 50MHz Reference clock by default)																
1	1	RMII1(TX_CLK inputs 50MHz Reference clock)																
28	RX_ER	O/PD	Receive error: This pin indicates that an error symbol has been detected within a received packet in both MII and RMII mode. In MII mode, RX_ER is asserted high synchronously to the rising edge of RX_CLK.															
9	RX_D0	O/PD	Receive data: Symbols received on the cable are decoded and presented on these pins synchronous to the rising edge of RX_CLK. When RX_DV is asserted, they contain valid data.															
10	RX_D1/WoL	O/LI/PD	<p>Receive data: Symbols received on the cable are decoded and presented on these pins synchronous to the rising edge of RX_CLK. When RX_DV is asserted, they contain valid data.</p> <p>Hardware Bootstrap: 0: Pin24 works as LED0 1: Pin24 works as WoL, must be pulled up.</p>															
11	RX_D2/nINT	O/OD/PD	<p>Receive data: Symbols received on the cable are decoded and presented on these pins synchronous to the rising edge of RX_CLK. When RX_DV is asserted, they contain valid data.</p> <p>MII Mode: A RX_D[3:0] is received RMII Mode:RX_D2 is used for interrupt pin.</p>															
12	RX_D3/TX_CLK_CTR	O/LI/PD	<p>Receive data: Symbols received on the cable are decoded and presented on these pins synchronous to the rising edge of RX_CLK. When RX_DV is asserted, they contain valid data.</p> <p>Hardware Bootstrap(RMII TX Clock control) : 0: RMII TX_CLK output, 1: RMII TX_CLK input</p>															
26	CRS/CRS_DV	O/PD	<p>MII Mode: Carrier Sense, asserted High to indicate the receive medium is non-idle.</p> <p>RMII Mode: This signal combines the RMII Carrier Sense and Receive Data Valid indications.</p>															
27	COL	O/PD	<p>Collision detect:</p> <p>In MII mode: For Full-Duplex mode, this pin is always low. In Half Duplex mode, this pin is asserted high only when both transmit and receive media are non-idle.</p>															
LED																		
24	LED0/PHY_ADR0	O/LI/PD	LED0, Link 10Mbps On, Active Blink. Hardware Bootstrap: PHY Address [0]															



25	LED1/PHY_ADR1	O/LI/PD	LED1, Link 100Mbps On, Active Blink. Hardware Bootstrap: PHY Address [1]
MISC			
1	R _{BIAS}	I	Bias Resistor Connection. External 2.49 kΩ 1% resistor connection to GND.
30	NC		

I: Input Signal

O: Output Signal

PWR: Power Supply

GND: Ground

EPAD: Exposed thermal PAD

PU: Pulled Up

PD: Pulled Down

LI: Latched Input during Power up or Reset

2 Electrical Characteristics

2.1 Absolute Maximum Ratings

Table2. Absolute Maximum Ratings

Parameter	Symbol	Value			Unit	Notes
		Min.	Typ.	Max.		
Power Supply Voltage	V _{D_{DA}_1V}	-0.2		1.5	V	Analog supply voltage
	V _{DD_1V}	-0.2		1.5	V	Digital supply voltage
	V _{D_{DA}_3V3}	-0.3		3.70	V	Analog supply voltage
	V _{DD_3V3}	-0.3		3.70	V	Digital supply voltage
Storage temperature	T _{STG}			150	°C	
Lead Soldering Temperature	T _{Lead}			260	°C	Soldering 10 seconds

2.2 Recommended Operating Conditions

Table3. Recommended Operating Conditions

Parameter	Symbol	Value			Unit	Notes
		Min.	Typ.	Max.		
Supply Voltage	V _{D_{DA}_1V}	1.10	1.20	1.30	V	
	V _{DD_1V}	1.10	1.20	1.30	V	
	V _{D_{DA}_3V3}	2.97	3.30	3.63	V	
	V _{DD_3V3}	2.97	3.30	3.63	V	



Parameter	Symbol	Value			Unit	Notes
		Min.	Typ.	Max.		
Operating Junction Temperature	T _{JUNC}			125	°C	
Operation temperature	T _{OPR}	0	25	70	°C	
Max. Junction Temperature	T _{JUNC}	0		125	°C	
Operation temperature	T _{OPR}	0	25	70	°C	DAP8201M
		-40	25	85	°C	DAP8201MI
Thermal resistance - junction to ambient	θ _{JA}		37.8		°C/W	JEDEC with no air flow TA=25°C
Thermal resistance - junction to board	θ _{JB}		16.1		°C/W	JEDEC with no air flow
Thermal resistance - junction to top case	θ _{JC-Top}		34.8		°C/W	JEDEC with no air flow



2.3 Power Consumption

Table4. Power consumption

Condition	MII	RMII	Unit
Reset	16.5	16.5	mW
Power Down	18.48	18.48	mW
Sleep Mode	20.13	20.13	mW
Active	147.84	145.2	mW
Link 10M	79.53	77.88	mW
Link 100M	217.47	201.3	mW
Traffic 10M	135.3	133.65	mW
Traffic 100M	212.52	189.35	mW

The power consumption is measured under room temperature with typical process DUT.

2.4 DC Characteristics

Table5. DC Characteristics

Parameter	Symbol	Value			Unit	Notes
		Min.	Typ.	Max.		
3.3V High-level input voltage	V _{IH}	2.0			V	V _{DD_3V3} =3.3V
3.3V Low-level input voltage	V _{IL}			0.8	V	V _{DD_3V3} =3.3V
3.3V High-level output voltage	V _{OH}	2.4			V	V _{DD_3V3} =3.3V
3.3V Low-level output voltage	V _{OL}			0.4	V	V _{DD_3V3} =3.3V

2.5 Timing Characteristics

2.5.1 Reset Timing

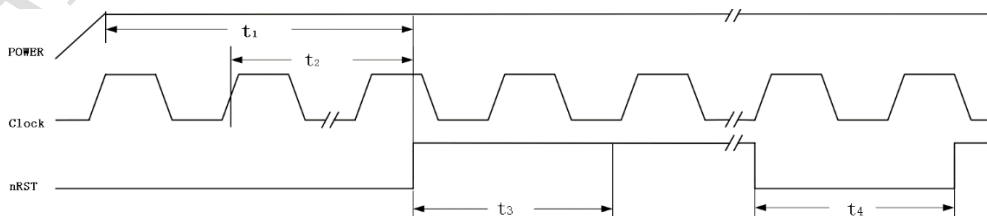

Figure 1. Reset Timing

Table6. Reset Timing



Parameter	Symbol	Value			Unit
		Min.	Typ.	Max.	
Reset assert time after power on	t_1	100			ms
Reset assert time after clock ready	t_2	10			ms
Reset de-assert time after power on	t_3	5			ms
Minimum reset pulse during normal operation	t_4	10			ms

2.5.2 MII Interface Timing

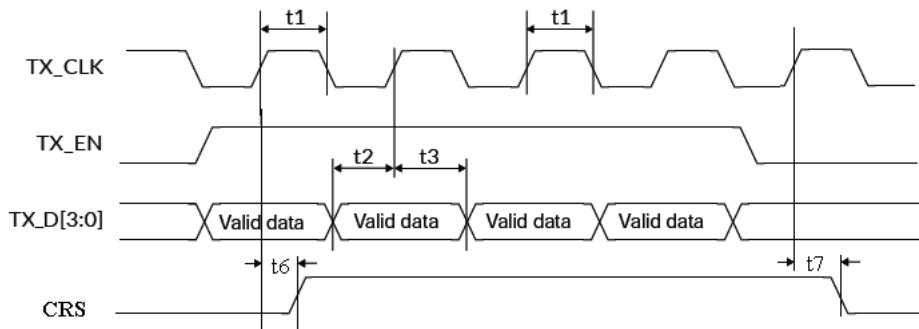

Figure 2. 10Mbps/100Mbps MII Transmit Timing

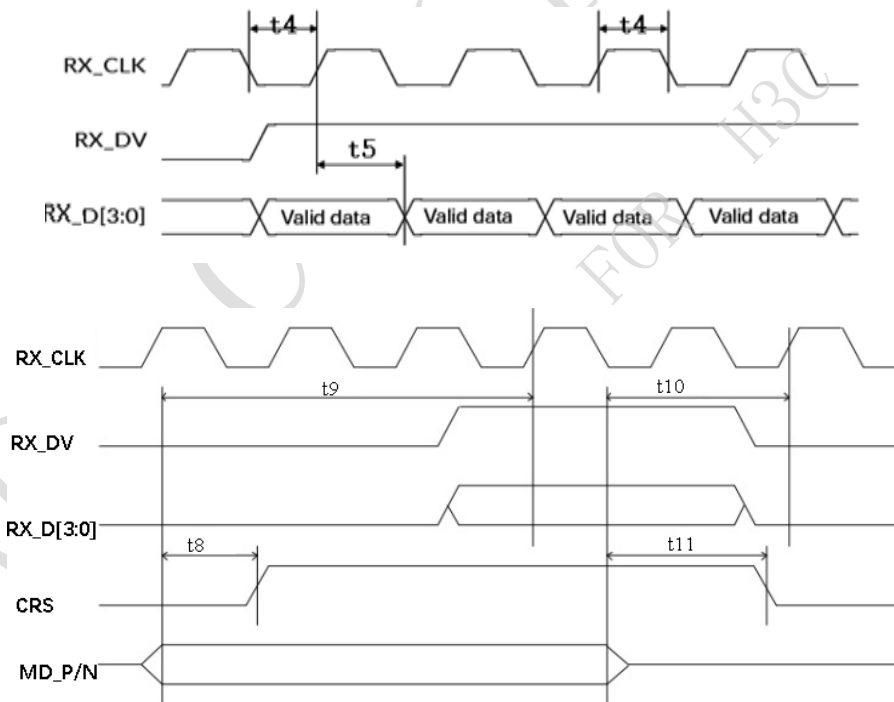

Figure 3. 10Mbps/100Mbps MII Receive Timing

Table7. 100Mbps MII Timing



Parameter	Symbol	Value			Unit	Notes
		Min.	Typ.	Max.		
TX_CLK high/low time	t1	14	20	26	ns	100Mbps MII mode
TX_D[3:0], TX_EN data setup to TX_CLK	t2	10			ns	
TX_D[3:0], TX_EN data hold from TX_CLK	t3	0			ns	
RX_CLK high/low time	t4	14	20	26	ns	
RX_CLK to RX_D[3:0], RX_DV, RX_ER delay	t5	10		30	ns	
TX_EN Sampled to CRS High	t6			40	ns	
TX_EN Sampled to CRS Low	t7			160	ns	
Receive Frame to CRS High	t8			130	ns	
Receive Frame to sampled clock edge of RX_DV	t9			150	ns	
End of Receive Frame to CRS Low	t10			240	ns	
End of Receive Frame to sampled clock edge of RX_DV	t11	10		120	ns	

Table8. 10Mbps MII Timing

Parameter	Symbol	Value			Unit	Notes
		Min.	Typ.	Max.		
TX_CLK high/low time	t1	140	200	260	ns	10Mbps MII mode
TX_D[3:0], TX_EN data setup to TX_CLK	t2	5			ns	
TX_D[3:0], TX_EN data hold from TX_CLK	t3	0			ns	
RX_CLK high/low time	t4	160	200	240	ns	
RX_CLK to RX_D[3:0], RX_DV, RX_ER delay	t5	100		300	ns	
TX_EN Sampled to CRS High	t6			400	ns	
TX_EN Sampled to CRS Low	t7			2000	ns	
Receive Frame to CRS High	t8			2000		
Receive Frame to sampled clock edge of RX_DV	t9			3200		
End of Receive Frame to CRS Low	t10			1000		
End of Receive Frame to sampled clock edge of RX_DV	t11	10		1000	ns	
TX_EN Sampled to CRS Low	t7			2000	ns	



2.5.3 RMII Interface Timing

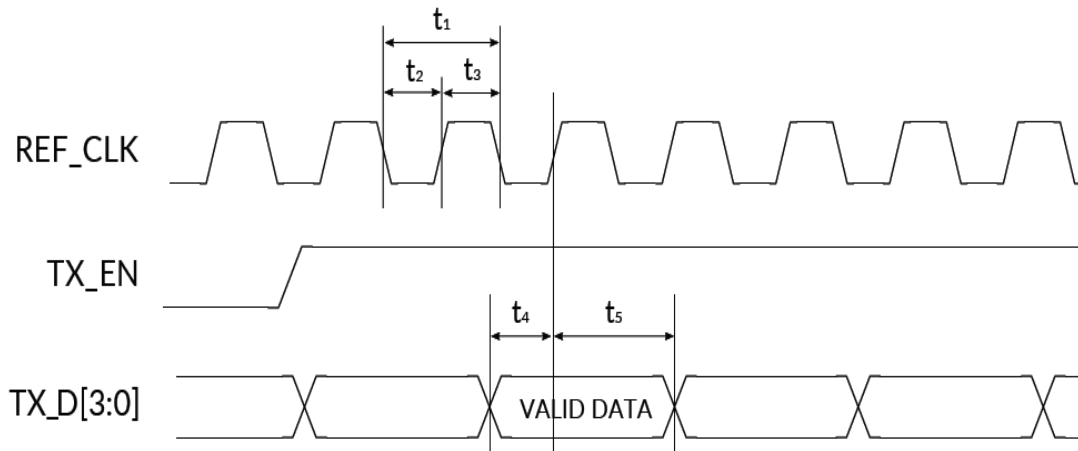

Figure 4. RMII Transmit Timing

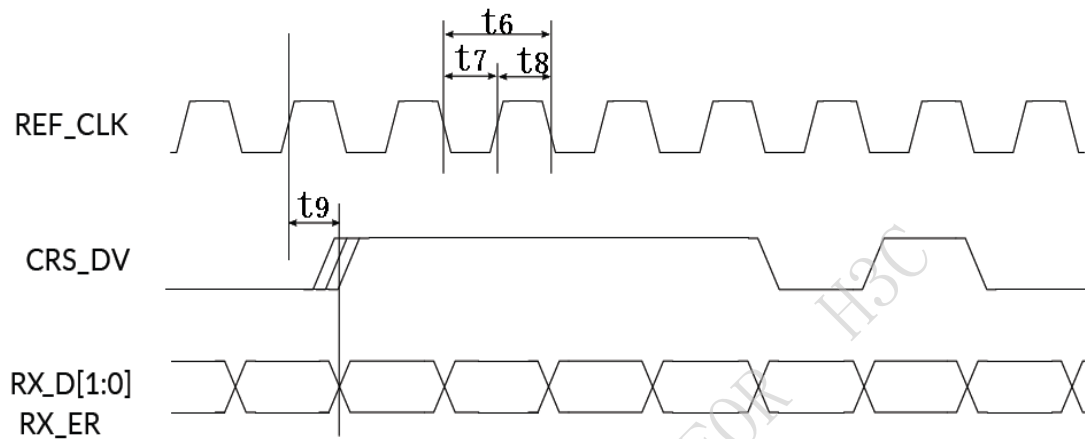

Figure 5. RMII Receive Timing

Table9. RMII Timing

Parameter	Symbol	Value			Unit	Notes
		Min.	Typ.	Max.		
REF_CLK(TX_CLK) clock period	t1, t6		20		ns	
REFCLK(TX_CLK) clock duty cycle		35	50	65	%	
TX_D[1:0], TX_EN, data setup to REF_CLK(TX_CLK) rising	t4	4			ns	
TX_D[1:0], TX_EN, data hold from REF_CLK(TX_CLK) rising	t5	2			ns	
RX_D[1:0], CRS_DV output delay from REF_CLK(TX_CLK) rising	t9	2			ns	

Table10. 10Mbps RMII Timing

Parameter	Symbol	Value			Unit	Notes
		Min.	Typ.	Max.		
TX_CLK high/low time	t1	140	200	260	ns	10Mbps



Parameter	Symbol	Value			Unit	Notes
		Min.	Typ.	Max.		
TX_D[3:0], TX_EN data setup to TX_CLK	t2	10			ns	MII mode
TX_D[3:0], TX_EN data hold from TX_CLK	t3	1			ns	
RX_CLK high/low time	t4	160	200	240	ns	
RX_CLK to RX_D[3:0], RX_DV, RX_ER delay	t5	100		300	ns	

2.6 Reference Clock Requirements

Table11. Crystal Specification

Parameter	Value			Unit	Notes
	Min.	Typ.	Max.		
Frequency		25		MHz	
Frequency Stability	-50		50	ppm	
ESR			50	Ω	
Drive Level			0.5	mW	

Table12. Oscillator Specification

Parameter	Value			Unit	Notes
	Min.	Typ.	Max.		
Frequency		25		MHz	
Frequency Stability	-50		50	ppm	
Rise/Fall Time			6	ns	10% - 90%
Cycle to Cycle Jitter			200	ps	short term (peak to peak value)
Duty Cycle	40		60	%	
V _{IH}	1.4		3.6	V	
V _{IL}			0.4	V	



3 Detail Description

3.1 Block Diagram

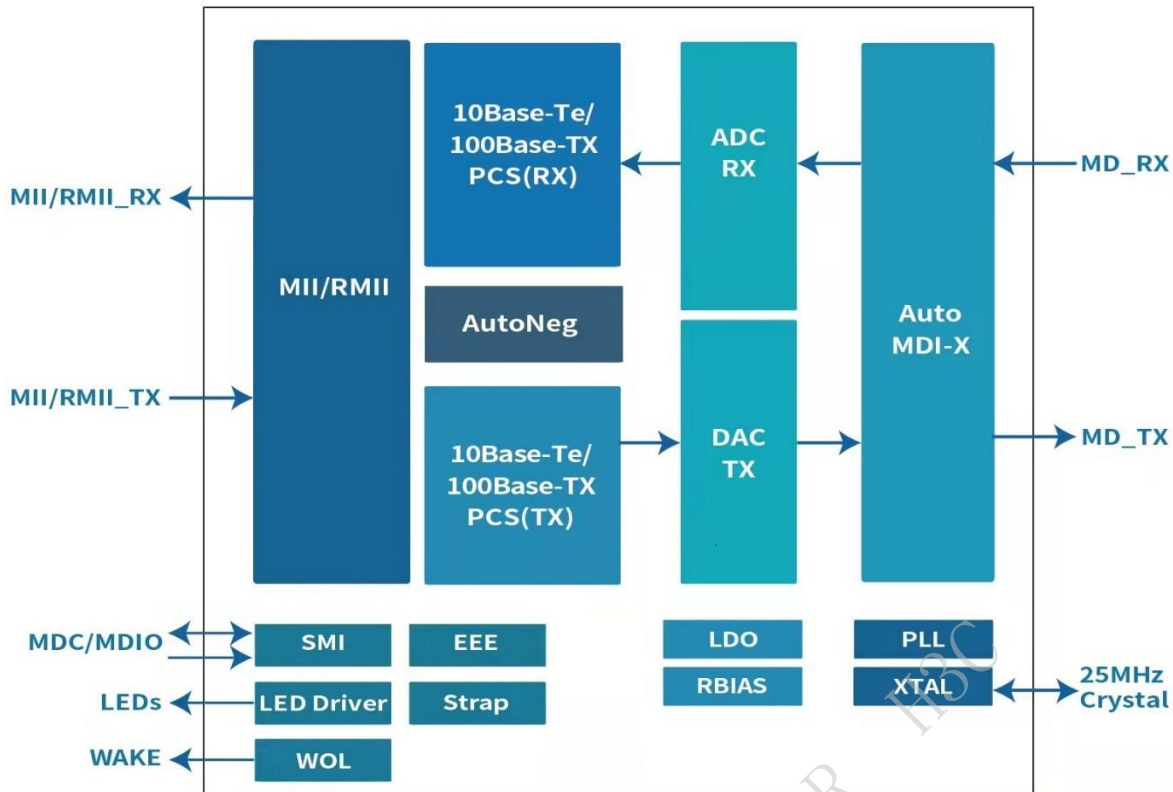

Figure 6. Functional Block Diagram

3.2 Feature Description

3.2.1 WoL (Wake-on-LAN)

Wake-on-LAN provides a mechanism to detect dedicated frames and inform the connected MAC through either a register status change, WoL indication, or an interrupt flag. The connected devices (MAC) placed above the Physical Layer to operate in a low power mode until special frames are detected. Supported WoL types include: Magic Packet.

When configured for Wake-on-LAN mode, the DAP8201M(I) will check all incoming frames to identify the Magic Packet frame.

A Magic Packet frame must also meet the basic requirements for the Ethernet Frame.



The specific Magic Packet sequence consists of 16 duplications of the IEEE address of this node, with no breaks or interruptions. This sequence can be located anywhere within the packet but must be preceded by a synchronization stream. The synchronization stream is defined as 6 bytes of 0xFF.

Table13. Magic Packet Structure

Destination (6 bytes)
Source (6 bytes)
MISC (X bytes, X >= 0)
FFFFFFFFFFFF (6 bytes)
Destination*16 (6*16 bytes)
MISC (X bytes, X >= 0)
CRC (4 bytes)

EXT 0x4004, 0x4005 and 0x4006 are the 48-bit MAC address registers.

EXT 0x4000 bit2 controls the WoL mechanism.

RX_D[1] just controls pin24 LED0 working as WoL interrupt. When the pad RX_D1 is externally pulled up, pin24 will work as WoL interrupt.

If EXT 0x4003 bit7 is 0, the dedicated WoL interrupt is programmed to a level, otherwise, it's programmed to a pulse; either is active low. When it's programmed to a pulse, the pulse width can be programmed via EXT 0x4003 bit9:8.

WoL interrupt is also wire-and to general PHY interrupt RX_D2_INT when the bit6 INT_WoL in Interrupt enable register (Basic Register 0x12) is set to 1. If the general PHY interrupt is triggered by WoL, it can be cleared by reading MII register 0x13 bit6.

NOTE:

When general PHY interrupt is used to monitor WoL interrupt, EXT 0x4003 bit7 should be 1, otherwise, the general PHY interrupt can't be read cleared.

Because PHY requires to receive packets from the line side, PHY cannot be powered down. If the link partner supports Energy Efficient Ethernet function, both ends can use EEE mode to save more power.

MII register 0x0 bit10 ISOLATE: When this bit is set to 1, the MII/RMII output pins are High Z. The MII/RMII inputs are ignored.

3.2.2 Auto-Negotiation

DAP8201M(I) supports Auto-Negotiation function which is defined in 802.3u. Auto-Negotiation function is to exchange information between two devices that share a link segment and to automatically configure both devices to take maximum advantage of their abilities.

The basic mechanism to achieve Auto-Negotiation is to pass information encapsulated within a burst of closely spaced



link integrity test pulses that individually meet the 10Base-Te Transmitter Waveform for Link Test Pulse. This burst of pulses is referred to as a Fast Link Pulse Burst.

The Auto-Negotiation function allows the devices to switch between the various operational modes in an ordered fashion, permits management to disable or enable the Auto-Negotiation function, and allows management to select a specific operational mode. The Auto-Negotiation function also provides a Parallel Detection function to allow 10Base-Te and 100Base-TX compatible devices to be recognized, even though they may not provide Auto-Negotiation.

3.2.3 Auto-MDIX

The function implements crossover detection automatically for MDI/MDIX cables which eases connection process. Auto-MDIX is enabled by default and can be configured via register (register 28, page 0), bits [2:1].

3.2.4 Automatic Polarity Correction

The DAP8201M(I) also implements polarity auto correction when cable happens to have wrong polarity connected when working at 10Base-Te mode. DAP8201M(I) will detect the polarity of Normal Link Pulse to determine the polarity of cable.

3.2.5 IEEE 802.3az-2010 EEE

The DAP8201M(I) supports IEEE 802.3az-2010(EEE: Energy Efficient Ethernet). EEE defines a negotiation method to enable link partners to decide whether EEE is supported.

Based on link utilization efficiency and EEE protocol, the transitions would work in different mode. When no packets are being transmitted, DAP8201M(I) would work in Low Power Idle mode to save power. As soon as packets to be transmitted, DAP8201M(I) returns to normal mode, and this doesn't impact the link status and dropping frames.

3.2.6 UTP Ethernet

DAP8201M(I) supports the 100Base-TX and 10Base-Te standard as defined by the IEEE 802.3 standard.

In 100M mode, the PHY will use two pairs MDI channels for communication. The communicated data are encoded/decoded in 4B/5B.

In 10M mode, the PHY will also use two pairs MDI channels for communication. The communicated data are encoded/decoded in Manchester.

3.2.7 MII Interface

The Media Independent Interface is a synchronous 4-bit wide nibble data interface that connects the PHY to the MAC in 100Base-TX and 10Base-Te modes. The MII is compliant with IEEE 802.3-2002 clause 22.

Additionally, the MII interface includes the carrier sense signal (CRS), as well as a collision detect signal (COL). The CRS signal asserts to indicate the reception or transmission of data. The COL signal asserts as an indication of a collision which can occur during Half-Duplex mode when both transmit and receive operations occur simultaneously.

Transmission: The MAC asserts the TX_EN signal firstly, then changes byte data into 4-bit and transmits them to the



PHY via TX_D[3:0]. The PHY will sample TX_D[3:0] synchronously with TX_CLK – the transmit clock signal supplied by the PHY.

Reception: The PHY asserts the RXDV signal firstly. It transmits the received data RX_D[3:0] clocked by RX_CLK. CRS and COL signals are used for collision detection and handling.

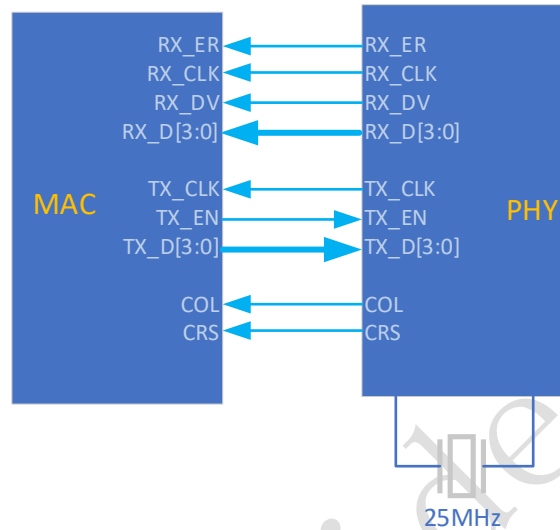

3.2.8 RMII Interface

The DAP8201M(I) incorporates the Reduced Media Independent Interface (RMII) as specified in the RMII specification from the RMII consortium. The purpose of this interface is to provide a reduced pin count alternative to the IEEE 802.3u MII as specified in Clause 22. Architecturally, the RMII specification provides an additional reconciliation layer on either side of the MII, but it can be implemented in the absence of an MII.

1. RMII1 mode: This is fully conforming to RMII standard. DAP8201M(I) can use clock from TX_CLK as reference clock for internal PLL. Configure bit 6 of extended register (address 0x50) to 1 to enable: not need 25MHz crystal at XI/XO.

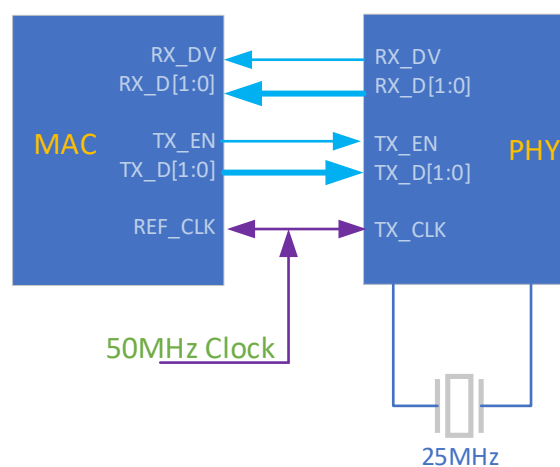



2. RMII2 mode: TX_CLK will output 50MHz to MAC, this can save one 50MHz clock.

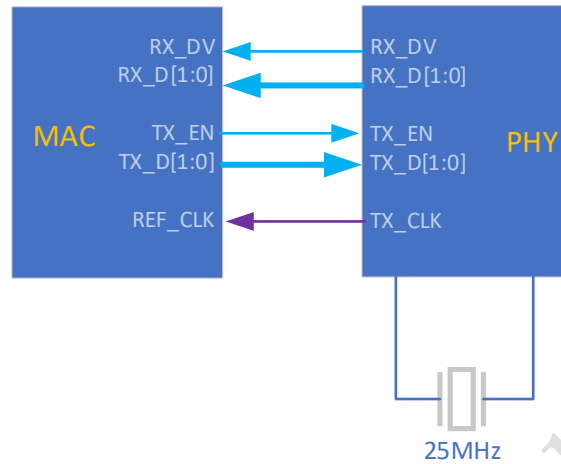

3.2.9 Reverse MII Interface

DAP8201M(I) supports reverse media independent interface. The only difference is the direction of TX_CLK and RX_CLK. For MII, TX_CLK and RX_CLK are output; for Reverse MII, TX_CLK and RX_CLK are input.

In Reverse MII mode, two PHYs are connected back-to-back via the MII interface to realize a repeater function on the physical layer.

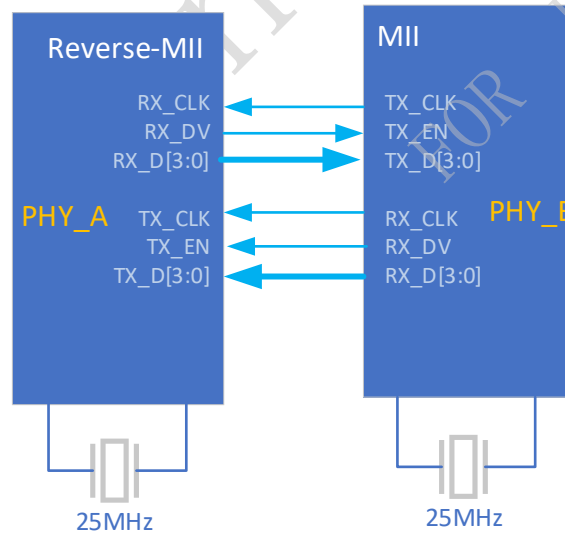

3.2.10 Loopback Mode

There are several options for loopback mode that test and verify various functional blocks within the PHY. Enabling loopback mode allows in-circuit testing of the digital and analog data paths. Generally, the DAP8201M(I) may be configured to 3 loopback modes.



Loopback Mode	Description
Internal Loopback	When BMCR register field Loopback is set to “1”, data sent through DAC to ADC directly.
External Loopback	An external loopback stub allows testing the complete data path without the need of a link partner. In this case it seems the data send through MII/RMII TX interface with be forwarded to MII/RMII RX interface through MDI interface
Remote Loopback	When Remote_loopback bit of extended register(0x4000) is set to “1”, data transmitted from MII/RMII tx interface will route back to MII/RMII rx interface. This checks if MII/RMII works correctly for remote link.

3.2.11 Hardware Bootstrap Configuration

The MII/RMII mode, and PHY address can be set by hardware. These configurations are setup through dedicated IO pin with external pullup/pulldown resistor. When power on reset is de-asserted, the hardware circuit will sample values on these dedicated IO pin.

Table14. Hardware Bootstrap

Function	Pin Number	Pin Name	Description
Hardware Bootstrap for Media Mode Select	8	RX_DV/MII_M	Pin8 Pin12 Media Mode
			0 0 MII
			0 1 Reverse MII
			1 0 RMII2(TX_CLK outputs 50MHz Reference clock by default)
			1 1 RMII3(TX_CLK inputs 50MHz Reference clock)
LED/WOL	10	RX_D1/WoL	0: pin24 works as LED0 1: pin24 works as WoL
PHY Address	24	LED0/PHY_ADR0	Pin25 Pin24 PHY Address
			0 0 00000
			0 1 00001
			1 0 00010
			1 1 00011
	25	LED1/PHY_ADR1	

3.2.12 Reset

There are two types of reset operation: Hardware Reset and Software Reset.

Hardware Reset: A hardware reset is implemented by asserting the nRST pin with low level: at least 10ms. All registers will be reset to default values and the hardware configuration will be re-latched.

Software Reset: A software reset is accomplished by writing BMC-C[15] Reset register to 1. All registers will be reset to default values and the hardware configuration will not be re-latched. Software need wait 100us to start other SMI operation.

3.2.13 Power Supply

DAP8201M(I) integrates the internal linear regulator and needs to supply a single 3.3V power source.



DAPU Confidential
FOR H3C



4 Registers

4.1 Register mapping

The DAP8201M(I) includes 2 register groups.

	Register Group	Description
1	Basic Register	Basic Register based on IEEE802.3
2	Extend Register	Extend Register based on Extended Register Mapping

Note: Basic Register is same to MII Register.

4.2 Register Access Types

Type	Description
RW	Read and write
RO	Read only.
SC	Self-clear. If default value is '0' ('1'), writing a '1' ('0') to this register field causes the function to be activated immediately, and then the field will be automatically cleared to '0' ('1').
RC	Read clear.
SWC	Software reset to 0.
SWS	Software reset to 1.
PS	Default value depends on power on strapping.
LH	Latch high.
LL	Latch Low.

4.3 Basic Register

Item	Address	Function	
	Offset	Register Name	Description
1	0x0	BMCR	Basic Mode Control
2	0x1	BMSR	Basic Mode Status
3	0x2	PHYID1	PHY Identifier Register #1
4	0x3	PHYID2	PHY Identifier Register #2
5	0x4	ANAR	Auto-Negotiation Advertisement
6	0x5	ANLPA	Auto-Negotiation Link Partner Ability
7	0x6	ANE	Auto-Negotiate Expansion
8	0x7	ANNPT	Auto-Negotiate Next Page Transmit
9	0x8	ANNPR	Auto-Negotiate Next Page Receive
10	0xA	MSSR	Master-Slave Status Register
11	0xD	MMD_AC	MMD Access Control
12	0xE	MMD_AADA	MMD Access Address and Data



13	0x10	PHYCR	PHY Control Register
14	0x11	PHYSR	PHY Status Register
15	0x12	INTCR	Interrupt Control Register
16	0x13	INTSR	Interrupt Status Register
17	0x14	SPCR	Speed Configuration Register
18	0x15	RECR	Receiver Error Counter Register
19	0x1E	EXT_ADD	Extended Register Address Register
20	0x1F	EXT_DATA	Extended Register Data Register

4.3.1 BMCR(Basic Mode Control Register, Address: Register 0x0)

Table15. BMCR

Bit	Name	Default	Description	Access
15	Reset	0	Reset. 1: PHY reset 0: Normal operation Software Reset. Writing a '1' to this bit to reset the PHY states machine. Register 0 (BMCR) and register 1 (BMSR) will return to default values once the reset operation is done.	RW, SC
14	Loopback	0	Internal Loopback Mode. 1: Enable internal loopback mode 0: Disable internal loopback mode	RW
13	Speed[0]	1	Speed Select Bit Speed [1:0]: 11: Reserved 10: Reserved 01:100Mbps 0: 10Mbps After completing auto negotiation, this bit will reflect the speed status. 1:100Base-T 0:10Base-Te	RW
12	AN_E	1	Auto-Negotiation Enable. 1: Enable Auto-Negotiation 0: Disable Auto-Negotiation	RW
11	PWD	0	Power Down. 1: Power down (only Management Interface and logic are active; link is down) 0: Normal Operation	RW
10	Isolate	0	Isolate. 1: Isolate 0: Normal Operation MII interface is isolated; the serial management interface (MDC, MDIO) is still active. When this bit is asserted, the PHY ignores TX_D[3:0], and TXCTL inputs, and presents a high impedance on RXC, RXCTL, RX_D[3:0]	RW
9	RS_AN	0	Restart Auto-Negotiation. 1: Restart Auto-Negotiation 0: Normal operation	RW/SC
8	Duplex	1	duplex mode set if auto-negotiation is disabled (register0 bit 12=0). 1: Full duplex 0: Half duplex	RW



			After completing auto-negotiation, this bit will reflect the duplex status. 1: Full duplex 0: Half duplex	
7	Collision Test	0	Collision Test. 1: Enable Collision Test 0: Normal Operation	RW
6	Speed [1]	0	Speed Select Bit 1 Refer to bit 0[13].	RW
5:0	Reserved	-	Reserved	-

4.3.2 BMSR (Basic Mode Status Register, Address: Register 0x1)

Table16. BMSR

Bit	Name	Default	Description	Access
15	100Base-T4	0	100Base-T4 Capability. 1: Enable 100Base-T4 support 0: Suppress 100Base-T4 support	RO
14	100Base-TX_F	1	100Base-TX Full Duplex Capability. 1= full-duplex 100Base-TX can be performed by PHY. 0=full-duplex 100Base-TX cannot be performed by PHY.	RO
13	100Base-TX_H	1	100Base-TX Half Duplex Capability. 1= half-duplex 100Base-TX can be performed by PHY. 0= half-duplex 100Base-TX cannot be performed by PHY.	RO
12	10Mbps_F	1	10Mbps Full Duplex Capability. 1= full-duplex 10Base-Te can be performed by PHY. 0=full-duplex 10Base-Te cannot be performed by PHY.	RO
11	10Mbps_H	1	10Mbps half -duplex Capability. 1= half-duplex 10Base-Te can be performed by PHY. 0= half-duplex 10Base-Te cannot be performed by PHY.	RO
10:9	Reserved	00	Reserved	RO
8	Ext_Status	1	Extended status register in 0x0F 1: Supported extended status register 0: Not supported extended status register	RO
7	Transmit_MII	0	1: PHY able to transmit from MII regardless of whether the PHY has detected that a valid link has been established. 0: PHY able to transmit from MII only when the PHY has detected that a valid link has been established.	RO
6	MF_PS	1	1: The PHY will accept management frames with preamble suppressed. 0: The PHY will not accept management frames with preamble suppressed. A minimum of 32 preamble bits are required: the first management interface read/write transaction after reset. One idle bit is required between any two management transactions as per IEEE 802.3u specifications.	RO
5	AN_C	0	Auto-Negotiation Complete. 1=Auto-Negotiation process is complete. 0=Auto-Negotiation process is not complete.	RO
4	Remote Fault	0	Remote Fault. 1=Remote fault condition is detected (cleared on read or by reset). 0=Remote fault condition is not detected.	RC
3	AN_A	1	Auto-Negotiation Ability.	RO



			1=Auto-Negotiation can be performed by PHY 0=Auto-Negotiation cannot be performed by PHY	
2	Link Status	0	Link Status 1: Linked 0: Not Linked This bit indicates whether the link was lost since the last read.: the current link status, read this register twice.	RO
1	Jabber Detect	0	Jabber Detect 1: Jabber condition detected 0: No Jabber detected	RO
0	Ext_Capability	1	1: Extended register capable (permanently=1) 0: Not extended register capable To indicate whether support EXTs, to access from address register 0x1E and data register 0x1F.	RO

4.3.3 PHYID1 (PHY Identifier Register #1, Address: Register 0x2)

Table17. PHYID1

Bit	Name	Default	Description	Access
15:0	PHYID_LSB		PHY Identifier Bit [18:3]	RO

4.3.4 PHYID2 (PHY Identifier Register #2, Address: Register 0x3)

Table18. PHYID2

Bit	Name	Default	Description	Access
15:10	PHYID_MSB		PHY Identifier Bit [24:19]	RO
9:4	Model Number	01 0010	Manufacture's Model Number	RO
3:0	Revision Number	1000	Revision Number	RO

4.3.5 ANAR (Auto-Negotiation Advertising, Address: Register 0x4)

This register contains the advertised abilities of this device as they will be transmitted to its link partner during auto-negotiation.

Table19. ANAR

Bit	Name	Default	Description	Access
15	Next Page*	0	Next Page Bit. 1: Advertise 0: Not advertised	RW
14	Reserved	0	Reserved	RO
13	Remote Fault	0	Remote Fault 1: Set Remote Fault bit 0: No Remote Fault bit	RW
12	Ext_Next_Page	1	Extended next page enable control bit 1: Local device supports transmission of extended next pages 0: Local device does not support transmission of extended next	RW



			pages.	
11	Asymmetric PAUSE*	1	Asymmetric PAUSE 1: Advertise asymmetric pause support 0: No support of asymmetric pause	RW
10	Pause*	1	1: MAC PAUSE implemented 0: MAC PAUSE not implemented	RW
9	100Base-T4	0	1: 100Base-T4 is supported by local node 0: 100Base-T4 not supported by local node	RO
8	100Base-TX_F*	1	1: 100Base-TX full duplex is supported by local node 0: 100Base-TX full duplex not supported by local node	RW
7	100Base-TX_H*	1	1: 100Base-TX half duplex is supported by local node 0: 100Base-TX half duplex not supported by local node	RW
6	10Base-Te-F*	1	1: 10Base-Te full duplex supported by local node 0: 10Base-Te full duplex not supported by local node	RW
5	10Base-Te_H*	1	1: 10Base-Te half duplex is supported by local node 0: 10Base-Te half duplex not supported by local node	RW
4:0	Selector Field	00001	Selector Field mode. 00001: IEEE 802.3	RO

*: This bit is updated immediately after the writing operation; However, the configuration does not take effect until any of the following occurs:

- Software reset is asserted by writing register 0x0 bit[15]
- Restart Auto-Negotiation is triggered by writing register 0x0 bit[9]
- The port is switched from power down to normal operation by writing register 0x0 bit[11]
- Link goes down

4.3.6 ANLPA (Auto-Negotiation Link Partner Ability, Address: Register 0x5)

This register contains the advertised abilities of the Link Partner as received during auto-negotiation. The content changes after a successful auto-negotiation if Next-pages are supported.

Table20. ANLPA

Bit	Name	Default	Description	Access
15	Next Page	0	Next Page Indication. 0: Transmitting the primary capability data page 1: Transmitting the protocol specific data page	RO
14	ACK	0	Acknowledge 1: Link partner acknowledges reception of local node's capability data word 0: No acknowledgement	RO
13	Remote Fault	0	Remote Fault 1: Link partner is indicating a remote fault 0: Link partner is not indicating a remote fault	RO
12	Reserved	-	Reserved.	-
11	Asymmetric Pause	0	Asymmetric Pause 1: Asymmetric pause control supported by Link Partner 0: No Asymmetric pause control supported by Link Partner When auto-negotiation is enabled, this bit reflects Link Partner ability.	RO
10	Pause	0	1: Link partner supports pause operation 0: Link partner does not support pause operation	RO
9	100Base-T4	0	100Base-T4 supporting	RO



			1: 100Base-T4 is supported by link partner 0: 100Base-T4 not supported by link partner	
8	100Base-TX-F	0	100Base-TX full duplex supporting 1: 100Base-TX full duplex is supported by link partner 0: 100Base-TX full duplex not supported by link partner	RO
7	100Base-TX	0	100Base-TX supporting 1: 100Base-TX is supported by link partner 0: 100Base-TX not supported by link partner This bit will also be set if the link in 100Base-TX is established by parallel detection.	RO
6	10Base-Te-F	0	10Base-Te full duplex supporting 1: 10Base-Te full duplex is supported by link partner 0: 10Base-Te full duplex not supported by link partner	RO
5	10Base-Te_H	0	10Base-Te half duplex supporting 1: 10Base-Te half duplex is supported by link partner 0: 10Base-Te half duplex not supported by link partner This bit will also be set if the link in 10Base-Te is established by parallel detection.	RO
4:0	Selector Field	00000	Link Partner's Binary Encoded Node Selector.	RO

4.3.7 ANE (Auto-Negotiation Expansion Register Address: Register 0x6)

This register contains additional status: NWay auto-negotiation.

Table21. ANE

Bit	Name	Default	Description	Access
15:5	Reserved	-	Reserved.	-
4	Parallel Detection Fault	0	Parallel Detection Fault 1: A fault has been detected via the Parallel Detection function 0: No fault has been detected via the Parallel Detection function	RC
3	Link Partner Next Page Ability	0	Link Partner Next Page Ability 1: Link Partner is Next Page able 0: Link Partner is not Next Page able	RO
2	Local Next Page Ability	1	Local Next Page Ability 1: Next Page is able 0: Not Next Page able	RO
1	Page Received	0	1: A New Page has been received 0: A New Page has not been received	RC
0	LP_AN_A	0	Link Partner Auto-Negotiation Ability If Auto-Negotiation is Enabled, This Bit Means: 1: Link Partner is Auto-Negotiation able 0: Link Partner is not Auto-Negotiation able	RO

4.3.8 ANNPT (Auto-Negotiation Next Page Transmit Register Address: Register 7)

Transmit the local auto-negotiation next page.

Table22. ANNPT

Bit	Name	Default	Description	Access
15	Next Page	0	Next Page Bit.	RW



			1: The page is not the last page 0: The page is the last page	
14	Reserved	0	Reserved	RO
13	MS_Page_M	0	Message Page Mode 1: Message Page 0: Unformatted Page	RW
12	ACK2	0	Acknowledge 1: Comply with message 0: No Comply with message	RW
11	Toggle	0	1: This bit in the previously exchanged Code Word is logic 0 0: The Toggle bit in the previously exchanged Code Word is logic 1	RO
10:0	MS_UF_Field	0x1	These bits are encoded as Message Code Field when bit[13] is set to 1, or as Unformatted Code Field when bit[13] is set to 0.	RW

4.3.9 ANNPR (Auto-Negotiation Next Page Received Register Address: Register 0x8)

Received the Auto-Negotiation next page from Link Partner.

Table23. ANNPR

Bit	Name	Default	Description	Access
15	Next Page	0	Next Page Bit. 1: The page is not the last page 0: The page is the last page	RO
14	Reserved	0	Reserved	RO
13	MS_Page_M	0	Message Page Mode 1: Message Page 0: Unformatted Page	RO
12	ACK2	0	Acknowledge 1: Comply with message 0: No Comply with message	RO
11	Toggle	0	1: This bit in the previously exchanged Code Word is logic 0 0: The Toggle bit in the previously exchanged Code Word is logic 1	RO
10:0	MS_UF_Field	0x0	These bits are encoded as Message Code Field when bit[13] is set to 1, or as Unformatted Code Field when bit[13] is set to 0.	RO

4.3.10 MSSR (Master-Slave Status Register Address: Register 0xA)

Table24. MSSR

Bit	Name	Default	Description	Access
15	MASTER/ SLAVE CONFIGURATI ON FAULT	0	Master / Slave Manual Configuration Fault Detected: 1: Manual Master/Slave Configuration fault detected. 0: No Manual Master/Slave Configuration fault detected This register bit will clear on read,	RO
14	MASTER/ SLAVE CONFIGURATI ON RESOLUTION	0	Master / Slave Configuration Results: 1: Configuration resolved to MASTER. 0: Configuration resolved to SLAVE.	RO
13	LOCAL RECEIVER STATUS	0	Local Receiver Status: 1: Local receiver is OK. 0: Local receiver is not OK.	RO



12	Remote Receiver	0	1: Remote Receiver OK 0: Remote Receiver not OK	RO
11	1000BASE-T Full Duplex	0	Advertise 1000BASE-T Full-Duplex Capability. 1: Advertise 0: Do not advertise	RO
10	1000BASE-T HALF DUPLEX	0	Link Partner 1000BASE-T Half Duplex Capable: 1: Link Partner capable of 1000Base-T Half Duplex. 0: Link partner not capable of 1000Base-T Half Duplex	RO
9:8	Reserved	0	Reserved.	RO
7:0	Idle Error Count	0x0	Idle Error Counter. The register indicates the idle error count since the last read operation performed to this register.	RO

4.3.11 MMD_AC (MMD Access Control; Address: Register 0xD)

Table25. MMD_AC

Bit	Name	Default	Description	Access
15:14	MMD Function	0	MMD Function about Data and Address 00: Address 01: Data; no post increment 10: Data; post increment on reads and writes 11: Data; post increment on writes only	WO
13:5	RSVD	0 0000 0000	Reserved.	RO
4:0	DEVAD	0	MMD Device Address. 00001: MMD1 00011: MMD3 00111: MMD7	WO

Note 1: Used in conjunction with the MAADR (Register 14) to provide access to the MMD address space.

Note 2: If the access of MAADR is: address (Function=00) then it is directed to the address register within the MMD associated with the value in the DEVAD field.

Note 3: If the access of MAADR is: data (Function=01) then both the DEVAD field and the MMD address register direct the MAADR data accesses to the appropriate registers within the MMD.

4.3.12 MMD_AADA (MMD Access Address Data, Address: Register 0xE)

Table26. MMD_AADR

Bit	Name	Default	Description	Access
15:0	Address Data	0x0000	[15:14]:00 It means MMD DEVAD's address register [15:14]:01, 10, or 11 It means MMD DEVAD's data register as indicated by the contents of its address register	RW

4.3.13 PHYCR (PHY Control Register, Address: Register 0x10)

Table27. PHYCR

Bit	Name	Default	Description	Access
15:7	RSVD	0x0	Reserved.	RO
6:5	MDI_CROSSOVER	0x3	MDI Crossover Mode: 11: Enable automatic crossover	RW



			10: Reserved 01: Manual MDI-X configuration 00: Manual MDI configuration	
4	RSVD	0	Reserved.	RW
3	CRS-TX	0	This bit is effective in 10BASE-Te half-duplex mode and 100BASE-TX mode: 1: Assert CRS on transmitting or receiving 0: Never assert CRS on transmitting, only assert it on receiving.	RW
2	EN_SEQ_Test	0	1: SQE test enabled, 0: SQE test disabled Note: SQE Test is automatically disabled in full-duplex mode regardless the setting in this	RW
1	POL_REV	1	If polarity reversal is disabled, the polarity is forced to be normal in 10BASE-Te. 1: Polarity Reversal Enabled 0: Polarity Reversal Disabled	RW
0	DIS_JAB	0	1: Disable 10BASE-Te jabber detection function 0: Enable 10BASE-Te jabber detection function	RW

4.3.14 PHYSR (PHY Status Register, Address: Register 0x11)

Table28. PHYSR

Bit	Name	Default	Description	Access
15:14	SPEED SELECTION	0x0	Speed Select Status: 11: Reserved 10: 1000 Mbps 01: 100 Mbps 00: 10 Mbps	RO
13	DUPLEX MODE	0	Duplex Mode Status: 1: Full Duplex 0: Half Duplex.	RO
12	PAGE RECEIVED	0	Page Received: This bit is latched high and will be cleared upon a read. 1: Page received. 0: No page received.	RO
11	SPEED DUPLEX RESOLVED	0	Speed Duplex Resolution Status: 1: Auto-Negotiation has completed or is disabled. 0: Auto-Negotiation is enabled and has not completed	RO
10	LINK STATUS	0	1: Link up 0: Link down	RO
9:7	RSVD	0x0	Reserved.	RO
6	MDI Crossover Status	0	1: MDIX 0: MDI This status bit is valid only when bit11 is 1. Bit11 is set when Auto-Negotiation is completed, or Auto-Negotiation is disabled. The bit value depends on register 0x10 “PHY specific function control register” bits6~bit5 configurations. Register 0x10 configurations take effect after software reset.	RO
5	Wirespeed downgrade	0	1: Downgrade 0: No Downgrade	RO
4	RSVD	0	Reserved.	RO
3	Transmit Pause	0	This status bit is valid only when bit11 is 1.	RO



			Bit11 is set when Auto-Negotiation is completed. This bit indicates MAC pause resolution. This bit is for information purposes only and is not used by the device. When in force mode, this bit is set to be 0. 1: Transmit pause enabled 0: Transmit pause disabled	
2	Receive Pause	0	This status bit is valid only when bit[11] is 1. Bit[11] is set when Auto-Negotiation is completed. This bit indicates MAC pause resolution. This bit is for information purposes only and is not used by the device. When in force mode, this bit is set to be 0. 1: Receive pause enabled 0: Receive pause disabled	RO
1	Polarity	0	1: Reverted polarity 0: Normal polarity	RO
0	Jabber	0	1: Jabber 0: No jabber	RO

4.3.15 INTCR (Interrupt Control Register, Address: Register 0x12)

Table29. INTCR

Bit	Name	Default	Description	Access
15:14	AN_ERR_INT_EN	0x0	Enable Auto-Negotiation Error Interrupt: 1: Enable Auto-Negotiation Error interrupt. 0: Disable Auto-Negotiation Error interrupt.	RW
14	SPEED_CHNG_INT_EN	0	Enable Speed Change Interrupt: 1: Enable Speed Change interrupt. 0: Disable Speed Change interrupt.	RW
13	DUPLEX_MODE_CHNG_INT_EN	0	Enable Duplex Mode Change Interrupt: 1: Enable Duplex Mode Change interrupt. 0: Disable Duplex Mode Change interrupt.	RW
12	PAGE_RECEIVED_INT_EN	0	Enable Page Received Interrupt: 1: Enable Page Received Interrupt. 0: Disable Page Received Interrupt.	RW
11	LINK_FAIL_INT_EN	0	Enable Link Fail Interrupt: 1: Enable Link Fail Interrupt. 0: Disable Link Fail Interrupt.	RW
10	LINK_COMPLETE_INT_EN	0	Enable Link Complete Interrupt: 1: Enable Link Complete Interrupt. 0: Disable LINK Complete Interrupt.	RW
9:7	RSVD	0x0	Reserved.	RW
6	WoL_INT_EN	0	Enable Wake-on-LAN Interrupt: 1: Enable Wake-on-LAN Interrupt. 0: Disable Wake-on-LAN Interrupt	RW
5	WS_DG_INT_EN	0	Wirespeed downgraded Interrupt 1: Enable Interrupt. 0: Disable Interrupt	RW
4:2	RSVD	0x0	Reserved.	RW
1	PL_CH_INT_EN	0	Enable Polarity Change Interrupt: 1: Enable Polarity Change interrupt. 0: Disable Polarity Change interrupt.	RW
0	JB_INT_EN	0	Enable Jabber Interrupt: 1: Enable Jabber interrupt. 0: Disable Jabber interrupt	RW



4.3.16 INTSR (Interrupt Status Register, Address: Register 0x13)

Table30. INTSR

Bit	Name	Default	Description	Access
15	AN_ERR_INT	0x0	Auto-Negotiation Error Interrupt: 1: Occur Auto-Negotiation Error interrupt 0: No Auto-Negotiation Error interrupt.	RO RC
14	SPEED_CHNG_INT_EN	0	Speed Change Interrupt: 1: Occur Speed Change interrupt. 0: No Speed Change interrupt.	RO RC
13	DUPLEX_MODE_CHNG_INT_EN	0	Duplex Mode Change Interrupt: 1: Occur Duplex Mode Change interrupt. 0: No Duplex Mode Change interrupt.	RO RC
12	PAGE_RECEIVED_INT_EN	0	Page Received Interrupt: 1: Occur Page Received Interrupt. 0: No Page Received Interrupt.	RO RC
11	LINK_FAIL_INT_EN	0	Link Fail Interrupt: 1: Occur Link Fail Interrupt. 0: No Link Fail Interrupt.	RO RC
10	LINK_COMPLETE_INT_EN	0	Link Complete Interrupt: 1: Occur Link Complete Interrupt. 0: No LINK Complete Interrupt.	RO RC
9:7	RSVD	0x0	Reserved.	RO RC
6	WoL_INT_EN	0	Wake-on-LAN Interrupt: 1: Occur Wake-on-LAN Interrupt. 0: No Wake-on-LAN Interrupt	RO RC
5	WS_DG_INT_EN	0	Wirespeed downgraded Interrupt 1: Occur Interrupt. 0: No Interrupt	RO RC
4:2	RSVD	0x0	Reserved.	RO RC
1	PL_CH_INT_EN	0	Polarity Change Interrupt: 1: Occur Polarity Change interrupt. 0: No Polarity Change interrupt.	RO RC
0	JB_INT_EN	0	Jabber Interrupt: 1: Occur Jabber interrupt. 0: No Jabber interrupt	RO RC

4.3.17 SPCR (Speed Configuration Register, Address: Register 0x14)

Table31. SPCR

Bit	Name	Default	Description	Access
15:12	RSVD	0x0	Reserved.	RO
11	EN_MDIO_L	1	1: To latch MII/MMD register's read out value during MDIO read 0: Do not latch MII/MMD register's read out value during MDIO read	RW
10:6	RSVD	0x0	Reserved.	RW
5	SP_DG_EN	1	1: Enables auto speed downgrade function. Writing this bit requires a software reset to up 0: Disable auto speed downgrade function	RW POS



4:2	AN_AT_SPDG	0x3	Attempts times (set value + additional 2) before downgrading. Such as 11: Attempts five times (set value 3 + additional 2) before downgrading. The number of attempts can be changed by these bits. Only take effect after software rese	RW
1	BP_Timer_Auto_SP	0	1:The wirespeed downgrade FSM will bypass the timer used for link stability check; 0: not bypass the timer, then links that established but hold for less than 2.5s would still be taken as failure, autoneg. retry counter will increase by 1.	RW
0	RSVD	0	Reserved.	RO

4.3.18 RECR (Receiver Error Counter Register, Address: Register 0x15)

Table32. RECR

Bit	Name	Default	Description	Access
15:0	RXERCNT[15:0]	0x0	RX_ER Counter: Receive error counter. This register saturates at the maximum value of 0xFFFF and hold it, not roll over.	RO SWC

4.3.19 EXT_ADD (Extended Register Address Register, Address: Register 0x1E)

Table33. EXT_ADD

Bit	Name	Default	Description	Access
15:0	EXT_ADD	0x0	Extended Register Address	RW

4.3.20 EXT_DATA (Extended Register Data Register, Register 0x1F)

Table34. EXT_DATA

Bit	Name	Default	Description	Access
15:0	EXT_DATA	0x0	Extended Register data	RW

4.4 Extended Register

4.4.1 EXT_10M_PWRCON (10Mbps Power Control Register, Address: Register 0x200A)

Table35. EXT_10M_PWRCON

Bit	Name	Default	Description	Access
15:11	RESV	11001	Reserved	RW
10	EN_10M_IDL		1: In 10BT mode , if there's no data or NLP to transmit, shut off DAC; otherwise turn on the DAC; 0: In 10BT, DAC will not be turn off.	RW
9:0	RESV	0x202	Reserved	RW

4.4.2 EXT_COMBO_CON (COMBO Control Register, Address: Register 0x4000)

Table36. EXT_COMBO_CON



Bit	Name	Default	Description	Access
15:12	RESV	0x0	Reserved	RW
11	REMOTE_LOOPBACK	0	set remote loopback 1: enable 0: disable	RW
10:6	RESV	0x0	Reserved	RW
5	JUMBO_EN	0	1: enable jumbo frame reception 0: disable jumbo frame reception Enable Jumbo frame reception up to 18KB frame, when disabled only up to 4.5KB frame supported	RW
4	RMII_RX_DV_SEL	0	Drive PAD CRS_DV of RMII by CRS_DV or RX_DV. 1: by RX_DV 0: by CRS_DV	RW
3	RESV	0	Reserved	RW
2	WoL_EN	0	1: enable WoL. 0: disable WoL	RW
1	RMII_EN	0	1: enable RMII mode 0: disable RMII mode	RW
0	CLK_SEL	0	Its default value is determined by power on strapping. 1: input TXC/RXC; 0: output TXC/RXC. [RMII_EN, CLK_SEL]: 2'b00: MII mode; 2'b01: RMII mode; 2'b10: RMII2 mode; 2'b11: RMII3 mode.	RW

4.4.3 EXT_PIN_CON (PAD Control Register, Address: Register 0x4001)

Table37. EXT_PIN_CON

Bit	Name	Default	Description	Access
15	INT_WoL	1	Control to output general interrupt or WoL interrupt to Pin24(LED0), when power on strapping value of RX_D1 is 1. 1: output general interrupt; 0: output WoL interrupt.	RW
14:6	RESV	0x3	Reserved	RW
5:4	XMII_DR	0x2	Xmii interface driver strength control in non-scan mode	RW
3:2	MDIO_DR	0x3	Mdio pin driver strength control in non-scan mode.	RW
1:0	RESV	0x3	Reserved	RW

4.4.4 EXT_COMBO2_CON (COMBO2 Control Register, Address: Register 0x4003)

Table38. EXT_COMBO2_CON

Bit	Name	Default	Description	Access
15	RESV	0	Reserved	RW
14	Slave_Jitter_T	0	Mux clk_dac to rxc in slave jitter test mode 1: enable 0: disable	RW
13:10	RESV	0x0	Reserved	RW
9:7	WoL_LTH_SEL	0x4	WoL_lth_sel[0] control WoL interrupt to be a level or a pulse. 1: a pulse;	RW



			0: a level. WoL_lth_sel[2:1] control WoL interrupt pulse width when WoL_lth_sel[0] is 1. 2'b00: 10us; 2'b01: 100us; 2'b10: 1ms; 2'b11: 10ms	
6	EN_Isolate_TX_CLK	1	When isolate bit (BMCR register) is 1, control to make TX_CLK input or not. 1'b1: input; 1'b0: keep TX_CLK previous direction.	RW
5	EN_Isolate_RX_CLK	1	When isolate bit (BMCR register) is 1, control to make RX_CLK input or not. 1'b1: input; 1'b0: keep RX_CLK previous direction.	RW
4:0	RESV	0x0	Reserved	RW

4.4.5 WoL_MAC_ADDH(WoL MAC Highest Address Register, Address: Register 0x4004)

Table39. WoL_MAC_ADDH

Bit	Name	Default	Description	Access
15:0	WoL_MAC_ADDR_H	0x0	highest 16 bits of MAC address used for WoL 47:32	RW

4.4.6 WoL_MAC_ADDM(WoL MAC Middle Address Register, Address: Register 0x4005)

Table40. WoL_MAC_ADDM

Bit	Name	Default	Description	Access
15:0	WoL_MAC_ADDR_M	0x0	Middle 16 bits of MAC address used for WoL 31:16	RW

4.4.7 WoL_MAC_ADDL(WoL MAC Lowest Address Register, Address: Register 0x4006)

Table41. WoL_MAC_ADDL

Bit	Name	Default	Description	Access
15:0	WoL_MAC_ADDR_L	0x0	Lowest 16 bits of MAC address used for WoL 31:16	RW

4.4.8 PKG_ST_CON (Package Generation Selftest Control, Address: Register 0x40A0)

Table42. PKG_ST_CON

Bit	Name	Default	Description	Access
15	PKG_CHK_EN	0	RX checker checks the UTP MII RX data; TX checker checks the UTP MII TX data. 1: Enable UTP RX/TX package checker. 0: Disable UTP RX/TX package checker	RW
14	PKG_GATE_EN	1	1: Enable gate all the clocks to package self test module when bit15 PKG_CHK_EN is 0, bit13 PKG_GEN_MODE is 1 and	RW



			bit12 PKG_GEN_EN is 0; 0: Not gate the clocks.	
13	PKG_GEN_TEST	1	1: normal mode, to send xMII TX data from PAD; 0: test mode, to send out the MII data generated by pkg_gen module.	RW
12	PKG_GEN_MODE	0	1: to enable pkg_gen generating MII packages. But, the data will only be sent to transceiver when Bit13 bp_pkg_gen is 1'b0. If pkg_burst_size is 0, continuous packages will be generated and will be stopped only when pkg_gen_en is set to 0; Otherwise, after the expected packages are generated, pkg_gen will stop, pkg_gen_en will be self-cleared.	RW
11:8	PKG_PREAM_LEN	0x8	The preamble length of the generated packages, in Byte unit. Pkg_gen function only support >=2 Byte preamble length. Values smaller than 2 will be ignored by the pkg_gen module.	RW
7:4	PKG_IPG_LEN	0xC	The IPG of the generated packages, in Byte unit. Pkg_gen function only support >=2 Byte preamble length. Values smaller than 2 will be ignored by the pkg_gen module.	RW
3	PKG_GEN_FORCE_gen	0	1: enable pkg_gen to send out the generated data even when the link is not established. 0: disable pkg_gen to send out the generated data even when the link is not established	RW
2	PKG_COR_CRC	0	1: to make pkg_gen to send out CRC error packages. 0: pkg_gen sends out CRC good packages.	RW
1:0	PKG_PL	0x0	Control the payload of the generated packages. 11: reserved 10: fix pattern 0x5AA55AA5... 01: random payload; 00: increased Byte payload	RW

4.4.9 PKG_LEN(Package Generation Length, Address: Register 0x40A1)

Table43. PKG_LEN

Bit	Name	Default	Description	Access
15:0	PKG_LENGTH	0x40	the length of the generated packages	RW

4.4.10 PKG_BS(Package Generation Burst Size, Address: Register 0x40A2)

Table44. PKG_BS

Bit	Name	Default	Description	Access
15:0	PKG_BUR_SIZE	0x0	the number of packages in a burst of package generation.	RW

4.4.11 PKG_RV_H(Package Receiver Valid High, Address: Register 0x40A3)

Table45. PKG_RVH

Bit	Name	Default	Description	Access
15:0	PKG_RV_H	0x0	PKG_RV[31:16], PKG_RV is the number of RX packages from wire whose CRC are good and length are >=64Byte and <=1518Byte.	RO RC



4.4.12 PKG_RV_L(Package Receiver Valid Low, Address: Register 0x40A4)

Table46. PKG_RVL

Bit	Name	Default	Description	Access
15:0	PKG_RV_L	0x0	PKG_RV [15:0], PKG_RV is the number of RX packages from wire whose CRC are good and length are >=64Byte and <=1518Byte.	RO RC

4.4.13 PKG_RX_OSH(Package Receiver OS High, Address: Register 0x40A5)

Table47. PKG_RX_OSH

Bit	Name	Default	Description	Access
15:0	PKG_RX_OSH	0x0	PKG_RX_OS[31:16], PKG_RX_OS is the number of RX packages from wire whose CRC are good and length are >1518Byte.	RO RC

4.4.14 PKG_RX_OSL(Package Receiver OS Low, Address: Register 0x40A6)

Table48. PKG_RX_OSL

Bit	Name	Default	Description	Access
15:0	PKG_RX_OSL	0x0	PKG_RX_OS [15:0], PKG_RX_OS is the number of RX packages from wire whose CRC are good and length are >1518Byte.	RO RC

4.4.15 PKG_RX_USH(Package Receiver US High, Address: Register 0x40A7)

Table49. PKG_RX_USH

Bit	Name	Default	Description	Access
15:0	PKG_RX_USH	0x0	PKG_RX_USH [31:16], PKG_RX_USH is the number of RX packages from wire whose CRC are good and length are <64Byte.	RO RC

4.4.16 PKG_RX_USL(Package Receiver US Low, Address: Register 0x40A8)

Table50. PKG_RX_USL

Bit	Name	Default	Description	Access
15:0	PKG_RX_USL	0x0	PKG_RX_USH [15:0], PKG_RX_USH is the number of RX packages from wire whose CRC are good and length are <64Byte.	RO RC

4.4.17 PKG_RX_ERR(Package Receiver Error, Address: Register 0x40A9)

Table51. PKG_RX_ERR

Bit	Name	Default	Description	Access
15:0	PKG_IB_ERR	0x0	PKG_IB_ERR is the number of RX packages from wire whose CRC are wrong and length are >=64Byte, <=1518By	RO RC



4.4.18 PKG_RX_OS_ERR(Package Receiver OS Error, Address: Register 0x40AA)

Table52. PKG_RX_OS_BAD

Bit	Name	Default	Description	Access
15:0	PKG_RX_OS_ERR	0x0	PKG_RX_OS_ERR is the number of RX packages from wire whose CRC are wrong and length are >1518Byte.	RO RC

4.4.19 PKG_RX_FRM (Package Receiver Fragment, Address: Register 0x40AB)

Table53. PKG_RX_FRM

Bit	Name	Default	Description	Access
15:0	PKG_RX_FRM	0x0	PKG_RX_FRM is the number of RX packages from wire whose length are <64Byte.	RO RC

4.4.20 PKG_RX_NOSFD (Package Receiver NOSFD, Address: Register 0x40AC)

Table54. PKG_RX_FRM

Bit	Name	Default	Description	Access
15:0	PKG_RX_NOSFD	0x0	PKG_RX_NOSFD is the number of RX packages from wire whose SFD is missed.	RO RC

4.4.21 PKG_TV_H(Package Transmit Valid High, Address: Register 0x40AD)

Table55. PKG_RVH

Bit	Name	Default	Description	Access
15:0	PKG_TV_H	0x0	PKG_TV[31:16], PKG_TV is the number of TX packages from wire whose CRC are good and length are >=64Byte and <=1518Byte.	RO RC

4.4.22 PKG_TV_L(Package Transmit Valid Low, Address: Register 0x40AE)

Table56. PKG_TV_L

Bit	Name	Default	Description	Access
15:0	PKG_TV_L	0x0	PKG_TV[15:0], PKG_TV is the number of TX packages from wire whose CRC are good and length are >=64Byte and <=1518Byte.	RO RC

4.4.23 PKG_TX_OSH(Package Transmit OS High, Address: Register 0x40AF)

Table57. PKG_TX_OSH

Bit	Name	Default	Description	Access
15:0	PKG_TX_OSH	0x0	PKG_TX_OS [31:16], PKG_TX_OS is the number of TX	RO



			packages from wire whose CRC are good and length are >1518Byte.	RC
--	--	--	---	----

4.4.24 PKG_TX_OSL(Package Transmit OS Low, Address: Register 0x40B0)

Table58. PKG_TX_OSL

Bit	Name	Default	Description	Access
15:0	PKG_TX_OSL	0x0	PKG_TX_OS [15:0], PKG_TX_OS is the number of TX packages from wire whose CRC are good and length are >1518Byte.	RO RC

4.4.25 PKG_TX_USH(Package Transmit US High, Address: Register 0x40B1)

Table59. PKG_TX_USH

Bit	Name	Default	Description	Access
15:0	PKG_TX_USH	0x0	PKG_TX_USH [31:16], PKG_TX_USH is the number of TX packages from wire whose CRC are good and length are <64Byte.	RO RC

4.4.26 PKG_TX_USL(Package Transmit US Low, Address: Register 0x40B2)

Table60. PKG_TX_USL

Bit	Name	Default	Description	Access
15:0	PKG_TX_USL	0x0	PKG_TX_USH [15:0], PKG_TX_USH is the number of TX packages from wire whose CRC are good and length are <64Byte.	RO RC

4.4.27 PKG_TX_ERR(Package Transmit Error, Address: Register 0x40B3)

Table61. PKG_TX_ERR

Bit	Name	Default	Description	Access
15:0	PKG_OB_ERR	0x0	pkg_ob_err is the number of TX packages from wire whose CRC are wrong and length are >=64Byte, <=1518By	RO RC

4.4.28 PKG_TX_OS_ERR(Package Transmit OS Error, Address: Register 0x40B4)

Table62. PKG_TX_OSBAD

Bit	Name	Default	Description	Access
15:0	PKG_TX_OS_ERR	0x0	It is the number of TX packages from wire whose CRC are wrong and length are >1518Byte.	RO RC

4.4.29 PKG_TX_FRM (Package Transmit Fragment, Address: Register 0x40B5)

Table63. PKG_TX_FRM

Bit	Name	Default	Description	Access
15:0	PKG_TX_FRM	0x0	PKG_TX_FRM is the number of TX packages from MII whose length are <64Byte.	RO RC



4.4.30 PKG_TX_NOSFD (Package Transmit NOSFD, Address: Register 0x40B6)

Table64. PKG_TX_FRM

Bit	Name	Default	Description	Access
15:0	PKG_TX_NOSFD	0x0	PKG_TX_NOSFD is the number of TX packages from MII whose SFD is missed.	RO RC

4.4.31 PKG_CON2 (Package Generation Configure2, Address: Register 0x40B7)

Table65. PKG_CON2

Bit	Name	Default	Description	Access
15:2	RSVD	-	Reserved.	RO
1	PKG_TXSCR	0	1: The package checker on TX side will check the transmit data generated by pkg_gen; 0: The package checker on TX side will check the transmit data of UTP GMII/MII.	RW
0	PKG_AZ_EN	0	1: Enable send LPI pattern during the IPG of the packages sent by pkg_gen. 0: Disable send LPI pattern during the IPG of the packages sent by pkg_gen	RW
8:0	PKG_IN_AZ_TIME	0x1FF	The time of LPI pattern is sent. Unit is us.	RW

4.4.32 PKG_CON3 (Package Generation Configure3, Address: Register 0x40B8)

Table66. PKG_CON3

Bit	Name	Default	Description	Access
15:11	RSVD	-	Reserved.	RW
10:0	PKG_PRE_AZ_TIME	0x0	The time from the end of last package to the beginning of LPI pattern. Unit is us.	RW

4.4.33 PKG_CON4 (Package Generation Configure4, Address: Register 0x40B9)

Table67. PKG_CON3

Bit	Name	Default	Description	Access
15:11	RSVD	-	Reserved.	RW
10:0	PKG_IN_AZ_TIME	0x0	The time of LPI pattern is sent. Unit is us.	RW

4.4.34 PKG_CON5 (Package Generation Configure5, Address: Register 0x40BA)

Table68. PKG_CON3

Bit	Name	Default	Description	Access
15:11	RSVD	-	Reserved.	RW
10:0	PKG_AFT_AZ_TIME	0x0	The idle time from the end of LPI pattern to the beginning of next package.	RW



			Unit is us.	
--	--	--	-------------	--

4.4.35 LED0_CON (LED0 Control Register, Address: Register 0x40C0)

Table69. LED0_CON

Bit	Name	Default	Description	Access
15	LED0_FORCE_EN	0	1 : enable LED0 force mode.	RW
14:13	LED0_FORCE_MODE	0x0	Valid when bit8 is set. 11: force LED Blink at Blink Mode2 10: force LED Blink at Blink Mode1 01: force LED ON 00: force LED OFF LED could blink at different frequency in Blink Mode1 and Blink Mode2.	RW
12	LED0_ACT_BLK_IND	0	When traffic is present, make LED BLINK no matter the previous LED0 status is ON or OFF, or make LED0 blink only when the previous LED0 is ON.	RW
11	LED0_FDX_ON_EN	0	1: If BLINK status is not activated, when PHY link up and duplex mode is full duplex, LED0 will be ON.	RW
10	LED0_HDX_ON_EN	0	1: If BLINK status is not activated, when PHY link up and duplex mode is half duplex, LED0 will be ON.	RW
9	LED0_TXACT_BLK_EN	1	1: If bit[13] is 1, or bit[13] is 0 and ON at certain speed or duplex more is/are activated, when PHY link up and TX is active, make LED0 blink at mode2.	RW
8	LED0_RXACT_BLK_EN	1	1: If bit[13] is 1, or bit[13] is 0 and ON at certain speed or duplex more is/are activated, when PHY link up and RX is active, make LED0 blink at mode2.	RW
7	LED0_TXACT_ON_EN	0	1: if BLINK status is not activated, when PHY link up and TX is active, make LED0 ON at least 10ms.	RW
6	LED0_RXACT_ON_EN	0	1: if BLINK status is not activated, when PHY link up and RX is active, make LED0 ON at least 10ms.	RW
5	LED0_HT_ON_EN	0	1: if BLINK status is not activated, when PHY link up and speed mode is 100Mbps, make LED0 ON;	RW
4	LED0_BT_ON_EN	1	1: if BLINK status is not activated, when PHY link up and speed mode is 10Mbps, make LED0 ON;	RW
3	LED0_COL_BLK_EN	0	1: if PHY link up and collision happen, make LED0 BLINK;	RW
2	LED0_HT_BLK_EN	0	1: if PHY link up and speed mode is 100Mbps, make LED0 BLINK;	RW
1	LED0_BT_BLK_EN	0	1: if PHY link up and speed mode is 10Mbps, make LED0 BLINK;	RW
0	DIS_LED0_TRY	1	when PHY is active and auto-negotiation is at LINK_GOOD_CHECK status, 1: LED will be on; 0: LED will be off.	RW

4.4.36 LED_COMCON (LED Common Control Register, Address: Register 0x40C1)

Table70. LED_COMCON

Bit	Name	Default	Description	Access
15	COL_BLK_SE	1	1 = when collision happens, and related LEDn cfg (n is 0/1/2)	RW



	L		register's bit3 led_col_blk_en is 1, LED blink at Blink Mode2; 0 = when collision happens, and related LEDn cfg (n is 0/1/2) register's bit3 led_col_blk_en is 0, LED blink at Blink Mode1. LED could blinks at different frequency in Blink Mode1 and Blink Mode2. Refer to EXT A00F[3:0] for the Blink Mode2 and Blink Mode1.	
15:10	RSVD	-	Reserved.	RO
9	REVERSE_LED_DUTY	0	1: to invert the duty cycle of ON and OFF, namely make LED ON time short and OFF time long.	RW
8	LPBK_LED_DIS	0	1 = In internal loopback mode, LED will not blink; 0 = In internal loopback mode, LED will blink;	RW
7	JABBER_LED_DIS	1	1 = when 10Mb/s Jabber happens, LED will not blink; 0 = when 10Mb/s Jabber happens, LED will still blink;	RW
6	COL_BLK_SEL	1	1: when collision happens, LED blink at Blink Mode2 with higher frequency; 0: when collision happens, LED blink at Blink Mode1 with lower frequency	RW
5	EN_LED_ACT_LEVEL	0	1: to make LED blink at different frequency (Blink mode 0) when traffic weight is high. 0: to make LED blink always at Blink mode 1 no matter what the traffic weight is	RW
4:0	LED_ACT_LEVEL_TH	0xC	Traffic is heavy or not's threshold. RX/TX traffic is monitored separately. In 1s interval, if RX or TX traffic active time > Led_act_level_th*42ms, then the traffic is heavy; otherwise, traffic is not heavy.	RW

4.4.37 LED_BLCON (LED Blink Control Register, Address: Register 0x40C2)

Table71. LED_BLCON

Bit	Name	Default	Description	Access
15:12	FREQ_SEL_0	0xE	Control the LED blink frequency in Blink mode 0. ON/OFF duty cycle could be reverted by 40C1h bit9 reverse_led_duty. Below description is the default ON/OFF cycle, that is reverse_led_duty=0. 4'd0=LED blink once every 10s, 6% OFF; 4'd1=LED blink once every 9.4s, 7% OFF; 4'd2=LED blink once every 8s, 8% OFF; 4'd3=LED blink once every 7.4s, 9% OFF; 4'd4=LED blink once every 6s, 11% OFF; 4'd5=LED blink once every 5s, 6% OFF; 4'd6=LED blink once every 4s, 8% OFF; 4'd7=LED blink once every 3s, 11% OFF; 4'd8=LED blink once every 2s, 16% OFF; 4'd9=LED blink once every 1s, 16% OFF; 4'd10=LED blink at 2Hz, 50% OFF; 4'd11=LED blink at 3Hz, 50% OFF; 4'd12=LED blink at 4Hz, 50% OFF; 4'd13=LED blink at 6Hz, 50% OFF; 4'd14=LED blink at 8Hz, 50% OFF; 4'd15=LED blink at 10Hz, 50% OFF;	RW
11:8	FREQ_SEL_1	0xC	Control the LED blink frequency in Blink mode 1. See description in bit15~12 Freq_sel_c0 for detail	RW
7:4	FREQ_SEL_2	0x7	Control the LED blink frequency in Blink mode 2. See description in bit15~12 Freq_sel_c0 for detail	RW



3:0	FREQ_SEL_3	0x5	Control the LED blink frequency in Blink mode 3. See description in bit15~12 Freq_sel_c0 for detail	RW
-----	------------	-----	--	----

4.4.38 LED1_CON (LED1 Control Register, Address: Register 0x40C3)

Table72. LED1_CON

Bit	Name	Default	Description	Access
15	LED1_FORCE_EN	0	1 : enable LED1 force mode.	RW
14:13	LED1_FORCE_MODE	0x0	Valid when bit8 is set. 11: force LED Blink at Blink Mode2 10: force LED Blink at Blink Mode1 01: force LED ON 00: force LED OFF LED could blink at different frequency in Blink Mode1 and Blink Mode2.	RW
12	LED1_ACT_BLK_IND	0	When traffic is present, make LED BLINK no matter the previous LED1 status is ON or OFF, or make LED1 blink only when the previous LED1 is ON.	RW
11	LED1_FDX_ON_EN	0	1: If BLINK status is not activated, when PHY link up and duplex mode is full duplex, LED0 will be ON.	RW
10	LED1_HDX_ON_EN	0	1: If BLINK status is not activated, when PHY link up and duplex mode is half duplex, LED0 will be ON.	RW
9	LED1_TXACT_BLK_EN	1	1: If bit[13] is 1, or bit[13] is 0 and ON at certain speed or duplex more is/are activated, when PHY link up and TX is active, make LED0 blink at mode2.	RW
8	LED1_RXACT_BLK_EN	1	1: If bit[13] is 1, or bit[13] is 0 and ON at certain speed or duplex more is/are activated, when PHY link up and RX is active, make LED0 blink at mode2.	RW
7	LED1_TXACT_ON_EN	0	1: if BLINK status is not activated, when PHY link up and TX is active, make LED0 ON at least 10ms.	RW
6	LED1_RXACT_ON_EN	0	1: if BLINK status is not activated, when PHY link up and RX is active, make LED0 ON at least 10ms.	RW
5	LED1_HT_ON_EN	0	1: if BLINK status is not activated, when PHY link up and speed mode is 100Mbps, make LED0 ON;	RW
4	LED1_BT_ON_EN	1	1: if BLINK status is not activated, when PHY link up and speed mode is 10Mbps, make LED0 ON;	RW
3	LED1_COL_BLK_EN	0	1: if PHY link up and collision happen, make LED0 BLINK;	RW
2	LED1_HT_BLK_EN	0	1: if PHY link up and speed mode is 100Mbps, make LED0 BLINK;	RW
1	LED1_BT_BLK_EN	0	1: if PHY link up and speed mode is 10Mbps, make LED0 BLINK;	RW
0	RSVD	0	Reserved.	RO



5 Environment

Table73. Environment

Attribute	Value
Moisture Sensitivity	Level 3
RoHS	RoHS2.0

DAPU Confidential
FOR H3C



6 Dimensions

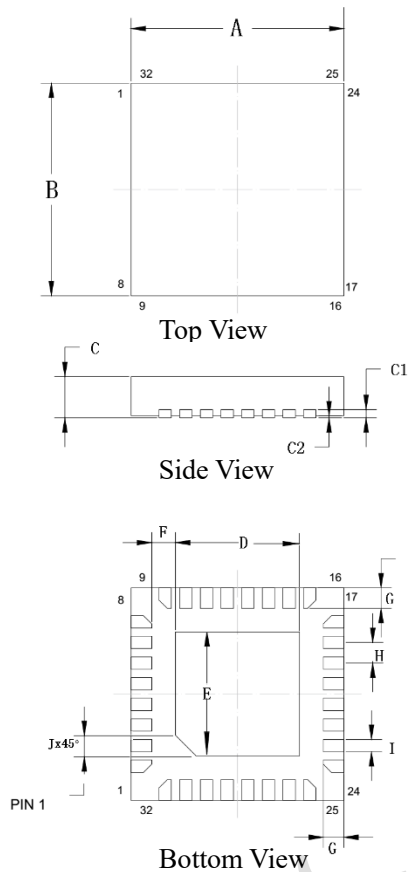

Dimension	Min.	Typ.	Max.
A	5BSC		
B	5BSC		
C	0.700	0.750	0.800
C1	0.203Ref		
C2	0	/	0.050
D	3.300	3.400	3.500
E	3.300	3.400	3.500
F	0.4Ref		
G	0.300	0.400	0.500
H	0.5BSC		
I	0.200	0.250	0.300
J	0.250	0.300	0.350

(Unit: mm)

Figure 7. QFN-32 Dimension

Disclaimer

This document only provides periodic information, and its contents may be updated from time to time according to actual situation of products without further notice. DAPU will not take any responsibility for any direct or indirect losses caused due to improper understand of this document.