

INS6310A —1:10 Ultra-Low Additive Jitter Differential Clock Buffer

FEATURES

- Two banks with 5 differential outputs each
 - LVPECL、LVDS、HCSL or Hi-Z (selectable per bank)
 - LVPECL additive jitter with clock source at 122.88MHz
 - 40 fs RMS (10KHz to 1MHz)
 - 80 fs RMS (12KHz to 20MHz)
- 3:1 Input Multiplexer
 - Two universal inputs operate up to 2.5GHz and accept LVPECL, LVDS, CML, SSTL, HSTL, HCSL or single-ended clocks
 - One crystal input accepts 10 to 40MHz crystal or single-ended clock
- High PSRR: -65/-76dBc (LVPECL/LVDS) at 156.25MHz
- LVCMOS output with synchronous enable input
- Pin-Controlled configuration
- V_{DD} core supply: 3.3V ± 5%
- 3 independent V_{DDO} output supplies: 3.3V/2.5V ± 5%
- Industrial temperature range: -40°C to +85°C
- Package: QFN48(7.0mm*7.0mm*0.75mm)

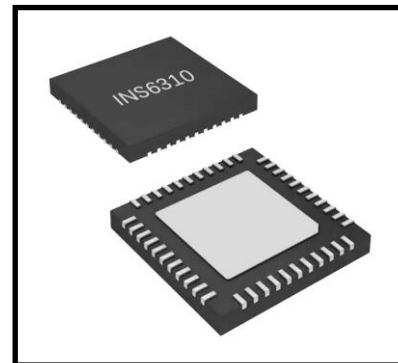

APPLICATIONS

- High speed Clock distribution and level translation
- Wireless BBU, RRU and Wired Communication
- Servers, Computing, PCI Express (PCIe)
- Switches, Routers, Line Cards, Timing Cards

GENERAL DESCRIPTIONS

The INS6310A is a high performance, versatility 10-output differential fanout buffer intended for high-frequency, low-jitter clock/data distribution and level translation. The input clock can be selected from two universal inputs or one crystal input. The selected input clock is distributed to two banks of 5 differential outputs and one LVCMOS output. Both differential output banks can be independently configured as LVPECL, LVDS, or HCSL drivers, or disabled. The LVCMOS output has a synchronous enable input for runt-pulse-free operation when enabled or disabled. The INS6310A operates from a 3.3V core supply and 3 independent 3.3V/2.5V output supplies.

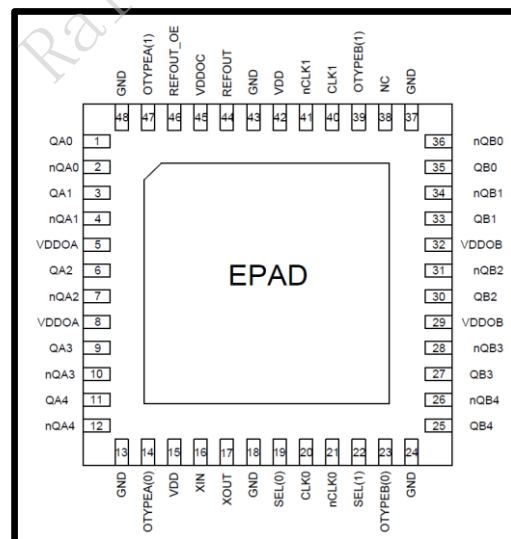

Table of Contents

1	GENERAL DESCRIPTION	4
2	FUNCTIONAL BLOCK DIAGRAM	4
3	PINOUTS	5
4	ELECTRICAL CHARACTERISTICS	6
5	FUNCTION DESCRIPTION	14
6	ENVIRONMENT	21
7	PACKAGE OUTLINE	21

Confidential
FOR Ra1tron

DAPU

1 GENERAL DESCRIPTION

The INS6310A is a 2.5-GHz, 10-output differential fanout buffer intended for high-frequency, low-jitter clock/data distribution and level translation. The input clock can be selected from two universal inputs or one crystal input. The selected input clock is distributed to two banks of 5 differential outputs and one LVCMOS output. Both differential output banks can be independently configured as LVPECL, LVDS, or HCSL drivers, or disabled. The LVCMOS output has a synchronous enable input for runt-pulse-free operation when enabled or disabled. The INS6310A operates from a 3.3V core supply and 3 independent 3.3V/2.5V output supplies.

The INS6310A provides high performance, versatility, and power efficiency, making it ideal for replacing fixed-output buffer devices while increasing timing margin in the system.

The INS6310A does not have power supply sequencing requirements between the core and output supply domains.

2 FUNCTIONAL BLOCK DIAGRAM

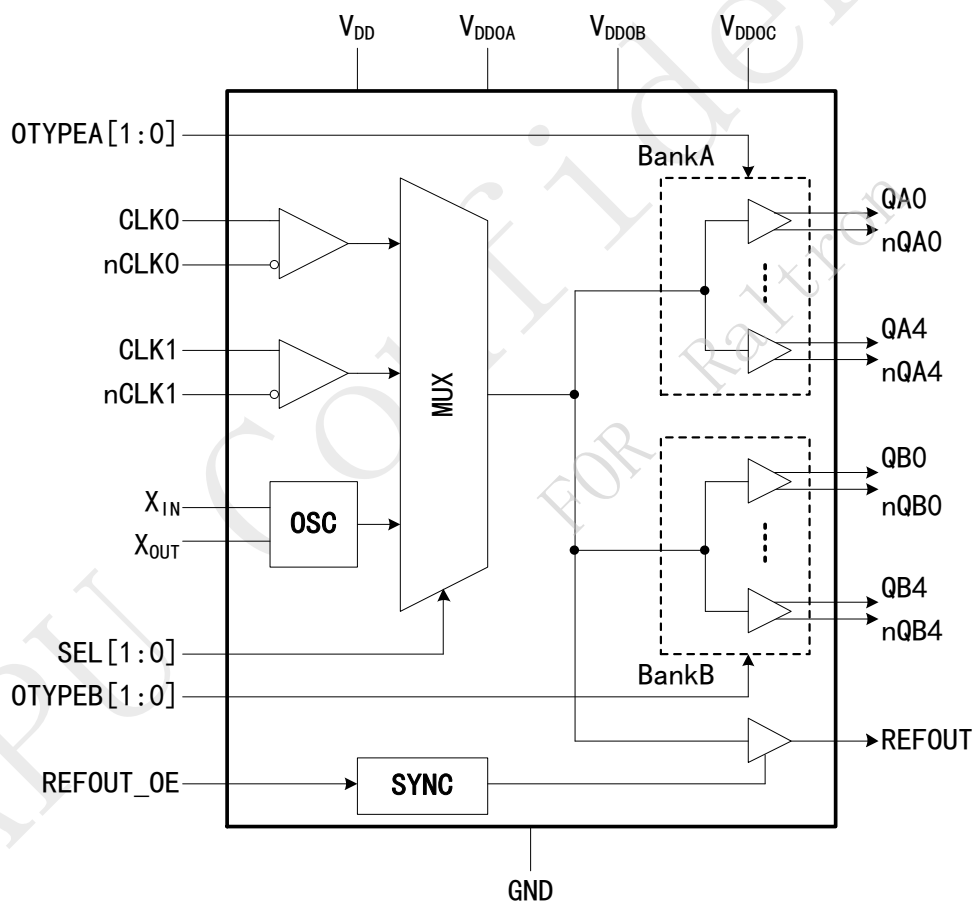

Figure 1. Block Diagram

3 PINOUTS

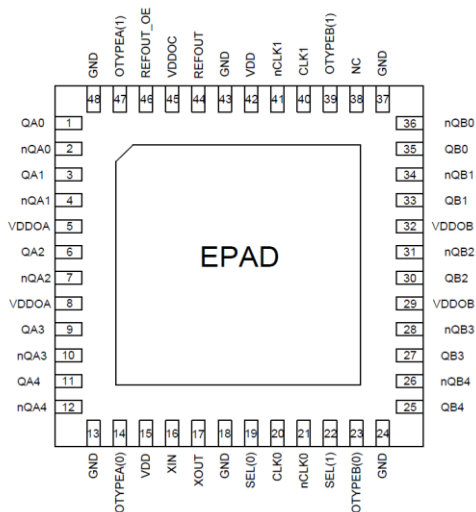

Figure 2. Pinouts Diagram

Table 1. Pin Definition

PIN No.	PIN Name	TYPE	DESCRIPTIONS
1,2	QA0,nQA0	OUT	Bank A Differential clock output 0
3,4	QA1,nQA1	OUT	Bank A Differential clock output 1
5,8	VDDOA	PWR	Power supply for Bank A output buffers. VDDOA can operate from 3.3V or 2.5V. The VDDOA pins are internally tied together. Bypass with a 0.1uF low-ESR capacitor placed very close to each VDDO pin.
6,7	QA2,nQA2	OUT	Bank A Differential clock output 2
9,10	QA3,nQA3	OUT	Bank A Differential clock output 3
11,12	QA4,nQA4	OUT	Bank A Differential clock output 4
13, 18, 24, 37, 43, 48	GND	GND	Ground
14,47	OTYPEA[0] OTYPEA[1]	IN	Bank A Outputs selection pins. Pull down internally.
15,42	VDD	PWR	Power supply for core and input buffer blocks. The VDD supply operates from 3.3V. Bypass with a 0.1uF low-ESR capacitor placed very close to each VDD pin.
16	XIN	IN	Input for crystal. Can also be driven by a XO, TCXO, or other external single-ended clock.
17	XOUT	OUT	Output for crystal. Leave XOUT floating if XIN is driven by a single-ended clock.
19,22	SEL[0] SEL[1]	IN	Clock input selection pins. Pull down internally.

PIN No.	PIN Name	TYPE	DESCRIPTIONS
20,21	CLK0,nCLK0	IN	Universal clock input 0 (differential/single-ended).
23,39	OTYPEB[0] OTYPEB[1]	IN	Bank A Outputs selection pins. Pull down internally.
25,26	nQB4,QB4	OUT	Bank B Differential clock output 4
27,28	nQB3,QB3	OUT	Bank B Differential clock output 3
29,32	V _{DDOB}	PWR	Power supply for Bank A output buffers. V _{DDOA} can operate from 3.3V or 2.5V. The V _{DDOA} pins are internally tied together. Bypass with a 0.1uF low-ESR capacitor placed very close to each V _{DDO} pin.
30,31	nQB2,QB2	OUT	Bank B Differential clock output 2
33,34	nQB1,QB1	OUT	Bank B Differential clock output 1
35,36	nQB0,QB0	OUT	Bank B Differential clock output 0
38	NC	-	Not connected internally. Pin may be floated or grounded.
40,41	nCLK1,CLK1	IN	Universal clock input 1 (differential/single-ended).
44	REFOUT	OUT	LVC MOS reference output. Enable output by pulling REFOUT_OE pin high.
45	V _{DDOC}	PWR	Power supply for Bank A output buffers. V _{DDOA} can operate from 3.3V or 2.5V. The V _{DDOA} pins are internally tied together. Bypass with a 0.1uF low-ESR capacitor placed very close to each V _{DDO} pin.
46	REFOUT_OE	IN	REFOUT enable input. Enable signal is internally synchronized to select clock input. Pull down internally.
	EPAD		Connect to the PCB ground plane for heat dissipation.

4 ELECTRICAL CHARACTERISTICS

Table 2. Absolute Maximum Ratings

Permanent device damage may occur if the absolute maximum ratings are exceeded. Functional operation should be restricted to the conditions as specified in the operational sections of this data sheet. Exposure to absolute maximum rating conditions for extended periods may affect device reliability.

Parameters	Symbol	Value	Unit
Power Supply Voltage	V _{DD} V _{DDOA} V _{DDOB} V _{DDOC}	-0.3~3.6	V
Input Voltage	V _{IN}	-0.3~V _{DD} +0.3	V
Storage Temperature Range	T _{STG}	-65~150	°C

Junction Temperature	T_J	150	°C
Thermal resistance from Junction to Ambient	θ_{JA}	28.5	°C/W

Table 3. Recommended Parameters

Parameters	Symbol	Value			Unit	Notes
		Min.	Typ.	Max.		
Core Supply Voltage	V_{DD}	3.15	3.3	3.45	V	
Output Supply Voltage	$V_{DDOX}^{(1)}$	3.135	3.3	3.45	V	
		2.375	2.5	2.625		
Core Supply Current	I_{VDD_CORE}		24	31	mA	All Outputs Disabled. Clock input 0 or 1 Selected.
			23	30	mA	All Outputs Disabled. Xin Selected.
	I_{VDD_LVDS}		50	75	mA	Additive Core Supply Current, Per LVDS Bank Enabled
	I_{VDD_LVPECL}		20	26	mA	Additive Core Supply Current, Per LVPECL Bank Enabled
	I_{VDD_HCSL}		32	42	mA	Additive Core Supply Current, Per HCSL Bank Enabled
	I_{VDD_LVCMOS}		4	5.2	mA	Additive Core Supply Current, Per LVCMOS Bank Enabled
Output Supply Current	I_{VDDO_LVDS}		24	31	mA	Additive Out Supply Current, Per LVDS Bank Enabled
	I_{VDDO_LVPECL}		230	299	mA	Additive Out Supply Current, Per LVPECL Bank Enabled
	I_{VDDO_HCSL}		72	94	mA	Additive Out Supply Current, Per HCSL Bank Enabled
	I_{VDDO_LVCMOS}		9	12	mA	Additive Out Supply Current, Per LVCMOS Bank Enabled
Ambient Temperature	T_A	-40		85	°C	

* (1) DDOX will represent DDOA/DDOB/DDOC in general when no distinction is needed

Table 4. Control Signals input Characteristics

Test Condition: $-40^{\circ}C \leq T_A \leq 85^{\circ}C, 3.15V \leq V_{DD} \leq 3.45V, 2.375V \leq V_{DDOX} \leq 2.625$ or $3.135V \leq V_{DDOX} \leq 3.45$

Parameters	Symbol	Value			Unit	Notes
		Min.	Typ.	Max.		
Control Signals (OTYPEA[0:1], OTYPEB[0:1], SEL[0:1], REFOUT_OE)						
High Level Input Current	I_{IH}			50	uA	
Low Level Input Current	I_{IL}	-5	0.1	5	uA	
Input High Voltage	V_{IH}	1.6		V_{DD}	V	
Input Low Voltage	V_{IL}	0		0.4	V	

Table 5. CLKx/nCLKx⁽²⁾

Test Condition: $-40^{\circ}\text{C} \leq \text{TA} \leq 85^{\circ}\text{C}$, $3.15\text{V} \leq \text{V}_{\text{DD}} \leq 3.45\text{V}$, $2.375\text{V} \leq \text{V}_{\text{DDOX}} \leq 2.625$ or $3.135\text{V} \leq \text{V}_{\text{DDOX}} \leq 3.45$, CLK driven differentially, input slew rate $\geq 3\text{V/ns}$

Parameters	Symbol	Value			Unit	Notes
		Min.	Typ.	Max.		
CLKx Single-Ended Input Clock Specifications						
Single-Ended Input High Voltage	V_{IH}			V_{DD}	V	CLKx driven single-ended (AC or DC coupled), nCLKx AC coupled to GND or externally biased within V_{CM} range
Single-Ended Input Low Voltage	V_{IL}	0			V	
Single-Ended Input Voltage Swing(P2P)	$V_{\text{LSE}}^{(3)}$	0.3		2	V	
Single-Ended Input Common-Mode Voltage	$V_{\text{CM}}^{(4)}$	0.25		$V_{\text{DD}}-1.2$	V	
Differential Input Clock Specifications (CLKx/nCLKx)						
Differential Input Voltage Swing	V_{ID}	0.15		1.3	V	
Differential Input Common-Mode Voltage	$V_{\text{CMD}}^{(5)}$	0.25		$V_{\text{DD}}-0.9$	V	$V_{\text{ID}}=800\text{mV}$
		0.25		$V_{\text{DD}}-1.1$	V	$V_{\text{ID}}=350\text{mV}$
		0.25		$V_{\text{DD}}-1.2$	V	$V_{\text{ID}}=150\text{mV}$
Differential Input High Voltage	V_{IHD}			V_{DD}	V	
Differential Input Low Voltage	V_{ILD}	0			V	
Mux Isolation, CLKin0 to CLKin	ISO_{IN}		-65		dBc	$F_{\text{IN}}=1000\text{MHz}$
			-71		dBc	$F_{\text{IN}}=500\text{MHz}$
			-82		dBc	$F_{\text{IN}}=200\text{MHz}$
			-84		dBc	$F_{\text{IN}}=100\text{MHz}$
Input Frequency (CLK/nCLK)						
Input Frequency Range	F_{IN}	0		2500	MHz	Functional up to 2.5GHz, Output frequency range and timing specified per output type (refer to LVPECL, LVDS, HCSL, LVCMOS output specifications)

* (2) CLKx/nCLKx represent CLK0/nCLK0 和 CLK1/nCLK1

(3) For clock input frequency $\geq 100\text{MHz}$, CLKx can be driven with single-ended (LVCMOS) input swing up to 3.3VPP.

For clock input frequency $< 100\text{MHz}$, the single-ended input swing should be limited to $2V_{\text{PP}}$ max to prevent input saturation (refer to Driving the Clock Inputs for interfacing 2.5V/3.3V LVCMOS clock input $< 100\text{MHz}$ to CLKx).

(4) CLKx driven single-ended (AC or DC coupled), nCLKx AC coupled to GND or externally biased within V_{CM} range

(5) AC coupled must be applied when V_{CM} of input signals exceed $V_{CMD Max.}$.

Table 6. X_{IN}/X_{OUT} Characteristics

Test Condition: $-40^{\circ}C \leq T_A \leq 85^{\circ}C, 3.15V \leq V_{DD} \leq 3.45V, 2.375V \leq V_{DDOX} \leq 2.625$ or $3.135V \leq V_{DDOX} \leq 3.45$

Parameters	Symbol	Value			Unit	Notes
		Min.	Typ.	Max.		
Crystal Input						
Crystal Mode			Fundamental			
Crystal Frequency Input Range	$f_{XIN/XOUT}$	10		40	MHz	
Effective Series Resistance	ESR			200	Ω	$10MHz < f_{XIN} \leq 30MHz$
		125			Ω	$30MHz < f_{XIN} < 40MHz$
Input Capacitance	C_{XO}		4		pF	
Single-ended input						
External Clock Input Frequency	f_{XIN}	DC		250	MHz	Single-Ended Input, Xout floating

Table 7. LVDS Outputs Characteristics

Test Condition: $-40^{\circ}C \leq T_A \leq 85^{\circ}C, 3.15V \leq V_{DD} \leq 3.45V, 2.375V \leq V_{DDOX} \leq 2.625$ or $3.135V \leq V_{DDOX} \leq 3.45$, CLK driven differentially, input slew rate $\geq 3V/ns$

Parameters	Symbol	Value			Unit	Notes
		Min.	Typ.	Max.		
QAn/nQAn, QBn/nQBn						
Maximum Output Frequency	$F_{OUT-MAX}$	1000	1600		MHz	Full V_{OD} Swing, $V_{OD} > 250mV, R_L = 100\Omega$ differential
		1500	2100		MHz	Reduced V_{OD} Swing, $V_{OD} > 200mV, R_L = 100\Omega$ differential
Output Voltage Swing	V_{OD}	250	400	450	mV	$T_A = 25^{\circ}C, DC$ Measurement, $R_L = 100\Omega$ differential
Change in Magnitude of V_{OD} for Complementary Output States	ΔV_{OD}	-50		50	mV	
Output Offset Voltage	V_{OFFSET}	1.125	1.25	1.375	V	
Change in Magnitude of V_{OFFSET} for Complementary Output States	ΔV_{OFFSET}	-35		35	mV	
Output Duty Cycle	Duty Cycle	45	50	55	%	
Output Rise/Fall Time, 20% to 80%	t_{Rise}		175	300	ps	uniform transmission line up to 10 inches with 50Ω

Parameters	Symbol	Value			Unit	Notes
	t_{Fall}					characteristic impedance, $R_L = 100\Omega$ differential, $C_L \leq 5p$
Propagation Delay	t_{Delay}	200	400	600	ps	$R_L = 100\Omega$ differential, $C_L \leq 5pF$
Output Skew	t_{Skew}		30	50	ps	Skew specified between any two CLKouts with the same buffer type. Load conditions per output type are the same as propagation delay specifications.
Part-to-part Output Skew	t_{PDP}		80	120	ps	
Additive RMS Jitter	t_j		132		fs	$F_{IN}=100MHz$ Slew Rate $\geq 3V/ns$ 1MHz to 20MHz
			103		fs	$F_{IN}=156.25MHz$ Slew Rate $\geq 3V/ns$ 1MHz to 20MHz
			33		fs	$F_{IN}=625MHz$ Slew Rate $\geq 3V/ns$ 1MHz to 20MHz
			138		fs	$F_{IN}=100MHz$ Slew Rate $\geq 3V/ns$ 10kHz to 20MHz
			99		fs	$F_{IN}=156.25MHz$ Slew Rate $\geq 3V/ns$ 10kHz to 20MHz
Noise Floor $f_{OFFSET} \geq 10MHz$	NF		-159.5		dBc/Hz	$F_{IN}=100MHz$ Slew Rate $\geq 3V/ns$
			-157		dBc/Hz	$F_{IN}=156.25MHz$ Slew Rate $\geq 3V/ns$
			-152.5		dBc/Hz	$F_{IN}=625MHz$ Slew Rate $\geq 3V/ns$

Table 8. LVPECL Outputs Characteristics

Test Condition: $-40^{\circ}C \leq T_A \leq 85^{\circ}C, 3.15V \leq V_{DD} \leq 3.45V, 2.375V \leq V_{DDOX} \leq 2.625$ or $3.135V \leq V_{DDOX} \leq 3.45$, CLK driven differentially, input slew rate $\geq 3V/ns$.

Parameters	Symbol	Value			Unit	Notes
		Min.	Typ.	Max.		
QAn/nQAn, QBn/nQBn						
Maximum Output Frequency	$F_{OUT-MAX}$	1000	1200		MHz	Full V_{OD} Swing, $V_{OD} \geq 600mV, R_L = 100\Omega$ differential, $V_{DDOX}=3.3V, R_T= 160\Omega$ to GND
		750	1000		MHz	Full V_{OD} Swing, $V_{OD} \geq 600mV, R_L = 100\Omega$ differential, $V_{DDOX}=2.5V, R_T= 91\Omega$ to GND
		1500	2200		MHz	Reduced V_{OD} Swing, $V_{OD} \geq 400mV, R_L = 100\Omega$ differential, $V_{DDOX}=3.3V, R_T= 160\Omega$ to GND

Parameters	Symbol	Value			Unit	Notes
		1500	2200			
Output Voltage Swing	V _{OD}	600	830	1000	mV	Reduced V _{OD} Swing, V _{OD} ≥ 400mV, R _L = 100Ω differential, V _{DDOX} =2.5V, R _T = 91Ω to GND
Output High Voltage	V _{OH}	V _{DDOX} -1.2	V _{DDOX} -0.9	V _{DDOX} -0.7	V	T _A = 25°C, DC Measurement, R _T = 50Ω to V _{DDO} - 2V
Output Low Voltage	V _{OL}	V _{DDOX} -2.0	V _{DDOX} -1.75	V _{DDOX} -1.5	V	
Output Duty Cycle	Duty Cycle	45	50	55	%	
Output Rise Time, 20% to 80%	t _{Rise}		250	350	ps	R _T = 160Ω to GND, uniform transmission line up to 10 inches with 50Ω characteristic impedance, R _L = 100Ω differential, C _L ≤ 5pF
Output Fall Time, 80% to 20%	t _{Fall}		180	300	ps	
Propagation Delay	t _{Delay}	180	360	540	ps	R _T = 160 Ω to GND, R _L = 50Ω differential, C _L ≤ 5pF
Output Skew	t _{Skew}		30	50	ps	Skew specified between any two CLKouts with the same buffer type. Load conditions per output type are the same as propagation delay specifications.
Part-to-part Output Skew	t _{PDP}		80	120	ps	
Additive RMS Jitter	t _j		55		fs	F _{IN} =100MHz Slew Rate≥3V/ns 1MHz to 20MHz
			35		fs	F _{IN} =156.25MHz Slew Rate≥3V/ns 1MHz to 20MHz
			25		fs	F _{IN} =625MHz Slew Rate≥3V/ns 1MHz to 20MHz
			60	98	fs	F _{IN} =100MHz Slew Rate≥3V/ns 10kHz to 20MHz
			30	78	fs	F _{IN} =156.25MHz Slew Rate≥3V/ns 10kHz to 20MHz
Noise Floor f _{OFFSET} ≥10MHz	NF		-161		dBc/Hz	F _{IN} =100MHz Slew Rate≥3V/ns
			-159		dBc/Hz	F _{IN} =156.25MHz Slew Rate≥3V/ns
			-154		dBc/Hz	F _{IN} =625MHz Slew Rate≥3V/ns

Table 9. HCSL Outputs Characteristics

Test Condition: -40°C ≤ T_A ≤ 85°C, 3.15V ≤ V_{DD} ≤ 3.45V, 2.375V ≤ V_{DDOX} ≤ 2.625 or 3.135V ≤ V_{DDOX} ≤ 3.45, CLK driven differentially, input slew rate ≥ 3V/ns.

Parameters	Symbol	Value	Unit	Notes
------------	--------	-------	------	-------

Parameters	Symbol	Value			Unit	Notes
		Min.	Typ.	Max.		
QAn/nQAn,QBn/nQBn						
Output Frequency Range	F _{OUT}	0		400	MHz	R _L = 50Ω to GND, C _L ≤ 5pF
Absolute Crossing Voltage	V _{CROSS}	160	350	460	mV	
Total Variation of V _{CROSS}	ΔV _{CROSS}			140	mV	
Output High Voltage	V _{OH}	520	750	920	mV	T _A = 25°C, DC Measurement, R _T = 50Ω to GND
Output Low Voltage	V _{OL}	-150	0.5	150	mV	
Output Duty Cycle	Duty Cycle	45	50	55	%	
Output Rise/Fall Time, 20% to 80%	t _{Rise} /t _{Fall}		300	500	ps	
Propagation Delay	t _{Delay}	295	590	885	ps	R _T = 50Ω to GND, C _L ≤ 5pF
Output Skew	t _{Skew}		30	50	ps	Skew specified between any two CLKouts with the same buffer type. Load conditions per output type are the same as propagation delay specifications.
Part-to-part Output Skew	t _{PDP}		80	120	ps	
Additive RMS Jitter	t _{J_PClE}		0.03	0.15	ps	PCIe Gen 3, PLL BW = 2-5MHz, CDR = 10MHz, F _{IN} =100MHz Slew Rate ≥ 0.6V/ns
			0.03	0.05	ps	PCIe Gen 4, PLL BW = 2-5MHz, CDR = 10MHz, F _{IN} =100MHz Slew Rate ≥ 1.8V/ns
	t _J		77		fs	V _{DDO} = 3.3V, R _T = 50Ω to GND F _{IN} =100MHz Slew Rate ≥ 3V/ns 1MHz to 20MHz
			86		fs	V _{DDO} = 3.3V, R _T = 50Ω to GND F _{IN} =156.25Hz Slew Rate ≥ 3V/ns 1MHz to 20MHz
Noise Floor f _{OFFSET} ≥10MHz	NF		-161		dBc/Hz	V _{DDO} = 3.3V, R _T = 50Ω to GND F _{IN} =100MHz Slew Rate ≥ 3V/ns
			-156		dBc/Hz	V _{DDO} = 3.3V, R _T = 50Ω to GND F _{IN} =156.25Hz Slew Rate ≥ 3V/ns

Table 10.LVCMOS Outputs Characteristics

Test Condition: -40°C ≤ T_A ≤ 85°C, 3.15V ≤ V_{DD} ≤ 3.45V, 2.375V ≤ V_{DDOX} ≤ 2.625 or 3.135V ≤ V_{DDOX} ≤ 3.45, CLK driven differentially, input slew rate ≥ 3V/ns.

Parameters	Symbol	Value			Unit	Notes
		Min.	Typ.	Max.		
Output High Voltage	V _{OH}	V _{DDOX} -0.1			V	1mA Load

Parameters	Symbol	Value			Unit	Notes
Output Low Voltage	V_{OL}			0.1	V	
Output High Current	I_{OH}		28		mA	$V_{DDOX}=3.3V$
			20		mA	$V_{DDOX}=2.5V$
Output Low Current	I_{OL}		28		mA	$V_{DDOX}=3.3V$
			20		mA	$V_{DDOX}=2.5V$
Output Frequency Range(F_{OUT}	0		300	MHz	$C_L \leq 5pF$
Output Duty Cycle	Duty Cycle	45	50	55	%	50% input clock duty cycle
Output Rise Time, 20% to 80%	t_{Rise}		225	500	ps	250MHz, uniform transmission line up to 10 inches with 50Ω characteristic impedance, $R_L = 50\Omega$ to GND, $C_L \leq 5pF$
Output Fall Time, 20% to 80%	t_{Fall}		225	400	ps	
Propagation Delay	t_{Delay}	900	1475	2300	ps	$V_{DDOX}=3.3V, C_L \leq 5pF$
		1000	1550	2700	ps	$V_{DDOX}=2.5V, C_L \leq 5pF$
Additive RMS Jitter, BW = 1MHz to 20MHz	t_j		132		fs	$V_{DDO} = 3.3V$ $C_L \leq 5pF$ $F_{IN}=100MHz$ Slew Rate $\geq 3V/ns$
Noise Floor, $f_{OFFSET} \geq 10MHz$			-158		dBc/Hz	
Output Enable/Disable Time	t_{EN}/t_{DIS}			3	Cycle	$C_L \leq 5pF$

5 FUNCTION DESCRIPTION

5.1 Control Signals

INS6310A has three groups of control signals:

- Input Selection
- Output Type Selection
- Reference Output Enable

Clock input selection is controlled using the SEL0 and SEL1 pins as shown in Table 11. Refer to Driving the Clock Inputs for clock input requirements. When CLK0 or CLK1 is selected, the crystal circuit is powered down. When Xin is selected, the crystal oscillator will start-up and its clock will be distributed to all outputs. Refer to Crystal Interface for more information. Alternatively, Xin may be driven by a single-ended clock, up to 250MHz, instead of a crystal.

Table 11. Input Selection

SEL[1]	SEL[0]	Selected Input
0	0	CLK0/nCLK0
0	1	CLK1/nCLK1
1	x	X _{IN} /X _{OUT}

The differential output buffer type for Bank A and Bank B outputs can be separately configured using the OTYPEA[1:0] and OTYPEB[1:0] inputs, respectively, as shown in table 12. For applications where all differential outputs are not needed, any unused output pin should be left floating with a minimum copper length to minimize capacitance and potential coupling and reduce power consumption. If an entire output bank will not be used, it is recommended to disable (Hi-Z) the bank to reduce power. Refer to Termination and Use of Clock Drivers for more information on output interface and termination techniques.

Table 12. Output Type Selection

OTYPEx[1]	OTYPEx[0]	Output Type (BankA or B)
0	0	LVPECL
0	1	LVDS
1	0	HCSL
1	1	Hi-Z

Notes: OTYPEx represent OTYPEA and OTYPEB

The reference output (REFOUT) provides a LVCMOS copy of the selected input clock. The LVCMOS output high level is referenced to the V_{DDO} voltage. REFOUT can be enabled or disabled using the enable input pin, REFOUT_OE, as shown in Table 13.

Table 13. Reference Output Enable

REFOUT_OE	Reference Output State
0	Hi-Z
1	Enabled

5.2 Input Clocks

CLK/nCLK differential inputs: The INS6310A has two differential inputs (CLK0/nCLK0 and CLK1/nCLK1) that can accept AC or DC coupled 3.3V/2.5V LVPECL, LVDS, CML, SSTL and other differential and single-ended signals that meet the input requirements specified in ELECTRICAL CHARACTERISTICS. The device can accept a wide range of signals due to its wide input common mode voltage range (V_{CM}) and input voltage swing (V_{ID}). It is recommended that the inputs have a high slew rate of 3 V/ns (differential) or higher in case to degrade the noise floor and jitter. For this reason, a differential input signal is recommended over single-ended because it typically provides higher slew rate and common-mode noise rejection.

CLK/nCLK single-ended inputs: It is possible to drive it with a single-ended clock. For large single-ended input signals, such as 3.3V or 2.5V LVCMOS, a 50Ω load resistor should be placed near the input for signal attenuation to prevent input overdrive as well as for line termination to minimize reflections. The CLK input has an internal bias voltage of about 1.4V, so the input can be AC coupled as shown in Figure3. The output impedance of the LVCMOS driver plus R1 should be close to 50 Ω to match the characteristic impedance of the transmission line and load termination.

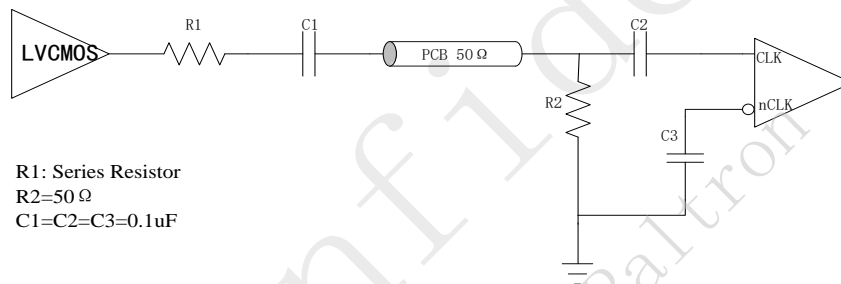

Figure 3. Single-Ended LVCMOS input, AC Coupling

A single-ended clock may also be DC coupled to CLKx as shown in Figure 4. A 50Ω load resistor should be placed near the CLKx input for signal attenuation and line termination. Because half of the single-ended swing of the driver ($V_{O,PP}/2$) drives CLKx, nCLKx should be externally biased to the midpoint voltage of the attenuated input swing ($(V_{O,PP}/2) \times 0.5$). The external bias voltage should be within the specified input common voltage (V_{CM}) range. This can be achieved using external biasing resistors in the kΩ range (R3 and R4) or another low-noise voltage reference. This will ensure the input swing crosses the threshold voltage at a point where the input slew rate is the highest.

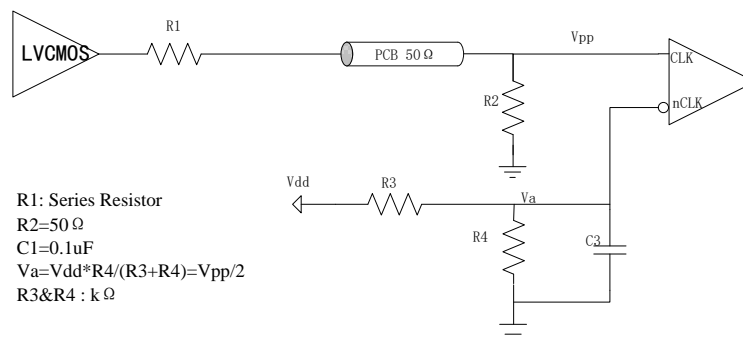

Figure 4. Single-Ended LVCMOS input, DC Coupling

X_{IN}/X_{OUT}: If the crystal oscillator circuit is not used, it is possible to drive the X_{in} input with a single-ended external clock as shown in Figure 5. The input clock should be AC coupled to the X_{in} pin, which has an internally generated input bias voltage, and the X_{out} pin should be left floating. While X_{in} provides an alternative input to multiplex an external clock, it is recommended to use either differential input (CLK_x) since it offers higher operating frequency, better common mode, improved power supply noise rejection and greater performance over supply voltage and temperature variations.

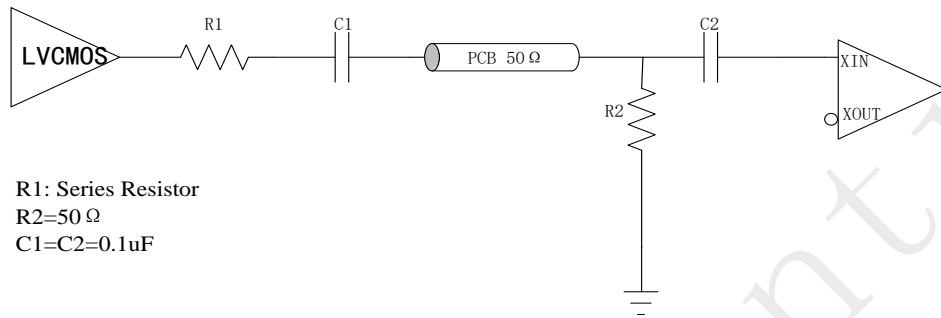

Figure 5. X_{IN} Single-Ended LVCMOS Clock

The INS6310A has an integrated crystal oscillator circuit that supports a fundamental mode, AT-cut crystal. The crystal interface is shown in Figure 6, while C_L is specified for the crystal and C_{Shunt} is the sum of C_{IN} and PCB C_{STRAY}.

As shown in Figure 6, an external resistor, R_{LIMIT}, can be used to limit the crystal drive level if necessary. If the power dissipated in the selected crystal is higher than the drive level specified for the crystal with R_{LIMIT} shorted, then a larger resistor value is mandatory to avoid overdriving the crystal. However, if the power dissipated in the crystal is less than the drive level with R_{LIMIT} shorted, then a zero value for R_{LIMIT} can be used. As a starting point, a suggested value for RLIM is 1.5kΩ.

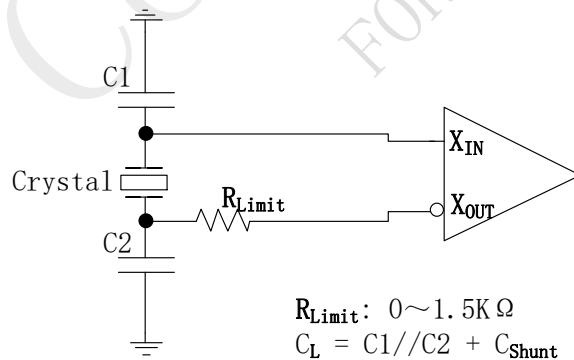

Figure 6. X_{IN}/X_{OUT} Crystal Interface

5.3 CLOCK OUTPUTS

INS6310A has two banks of 5 differential outputs and one LVCMOS output which can be independently supplied with 3.3V or 2.5V.

Table 14. Clock Outputs

Bank	Outputs
Bank A	QA0, QA1, QA2, QA3, QA4
Bank B	QB0, QB1, QB2, QB3, QB4
REFOUT	REFOUT

Table 2 following will be the state of the outputs.

Table 15. Input Vs. Output States

SEL[1]	Input Clock	Output State
Logic Low	CLKx=Open nCLKx=Open	Logic Low
	CLK= Logic High nCLK= Logic Low	Logic High
	CLK= Logic Low nCLK= Logic High	Logic Low
	CLK and nCLK short	Logic Low
Logic High	X _{IN} = Logic High	Logic Low
	X _{IN} = Logic Low	Logic High

Notes

- Unused outputs should be left floating with a minimum copper length to minimize capacitance. In this way, this output will consume minimal output current because it has no load.

5.3.1 Termination and Use of Clock Drivers

When terminating clock drivers keep in mind these guidelines for optimum phase noise and jitter performance:

- Transmission line theory should be followed for good impedance matching to prevent reflections.
- Clock drivers should be presented with the proper loads.
 - LVDS outputs are current drivers and require a closed current loop.
 - HCSL drivers are switched current outputs and require a DC path to ground via 50Ω termination.
 - LVPECL outputs are open emitter and require a DC path to ground.
- Receivers should be presented with a signal biased to their specified DC bias level (common mode voltage) for proper operation. Some receivers have self-biasing inputs that automatically bias to the proper voltage level; in this case, the signal should normally be AC coupled.

It is possible to drive a non-LVPECL or non-LVDS receiver with a LVDS or LVPECL driver as long as the above guidelines are followed. Check the datasheet of the receiver or input being driven to determine the best termination and coupling method to be sure the receiver is biased at the optimum DC voltage (common mode voltage)

Termination for LVDS Driver

For DC coupled operation, terminate with 100Ω as close as possible to the LVDS receiver. For AC coupled operation by adding DC blocking capacitors, the load termination resistor and AC coupling capacitors should be placed as close as possible to the receiver inputs to minimize stub length, as shown in Figure 7

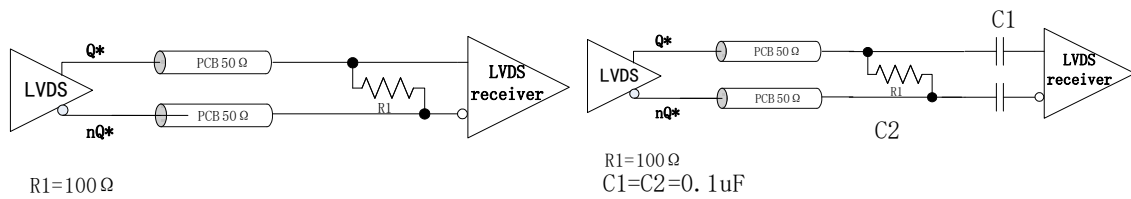

Figure 7. LVDS DC&AC Coupling

Termination for LVPECL Driver

For DC coupled operation of an LVPECL driver, terminate with $50\ \Omega$ to $V_{DDO} - 2V$. Alternatively terminate with a Thevenin equivalent circuit for V_{DDO} (output driver supply voltage) = 3.3V and 2.5V. In the Thevenin equivalent circuit, the resistor dividers set the output termination voltage (V_{TT}) to $V_{DDO} - 2V$. as shown in Figure 8

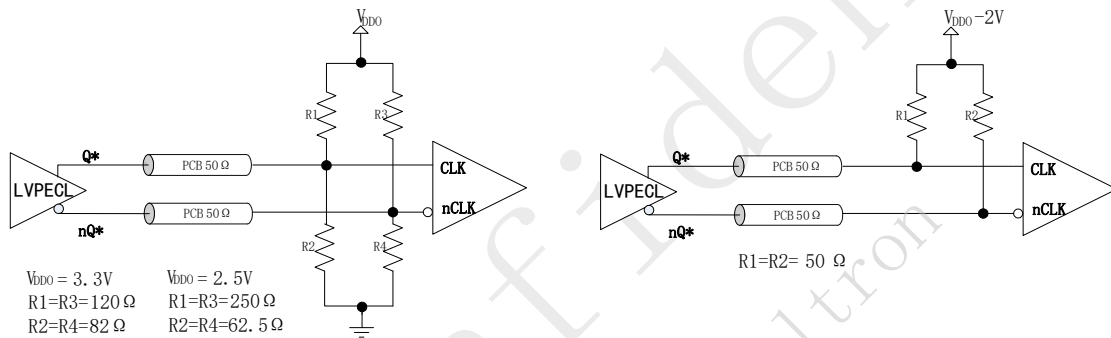

Figure 8. LVPECL DC Coupling

When AC coupling an LVPECL signal use $160\ \Omega$ emitter resistors (or $91\ \Omega$ for $V_{DDO} = 2.5V$) close to the LVPECL driver to provide a DC path to ground as shown in Figure 9. For proper receiver operation, the signal should be biased to the DC bias level (common mode voltage) specified by the receiver. The typical DC bias voltage (common mode voltage) for LVPECL receivers is 2.0V. Alternatively, a Thevenin equivalent circuit forms a valid termination as shown in Figure 9 for $V_{DDO} = 3.3V$ and 2.5V. This Thevenin circuit is different from the DC coupled example in Figure 8, since the voltage divider is setting the receiver input common mode voltage.

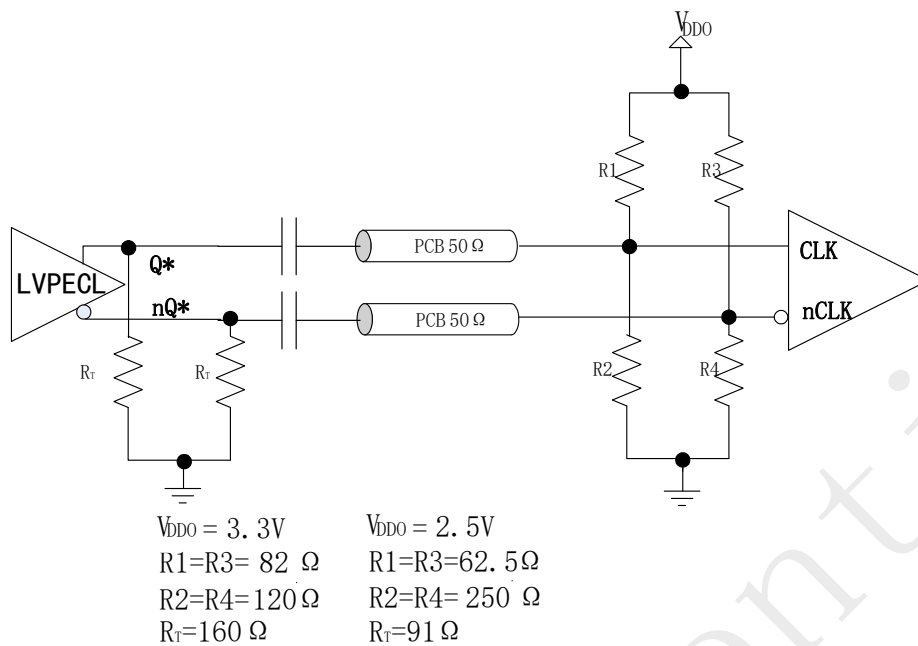

Figure 9. LVPECL AC coupling, Thevenin equivalent

Termination for HSCL Driver

For DC coupled operation of an HCSL driver, terminate with 50Ω to ground near the driver output as shown in Figure 10. Series resistors, R_s , may be used to limit overshoot due to the fast transient current. Because HCSL drivers require a DC path to ground, AC coupling is not allowed between the output drivers and the 50Ω termination resistors.

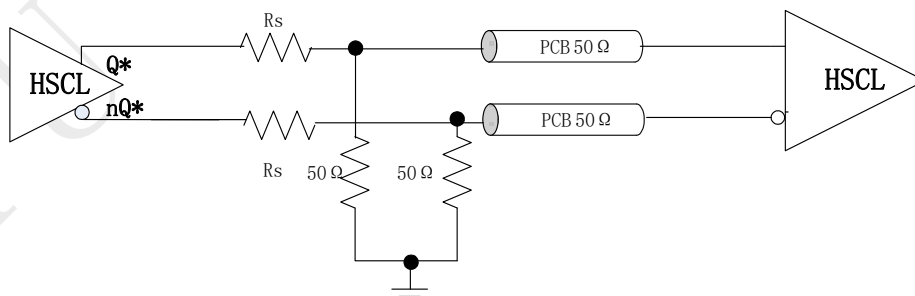

Figure 10. HCSL Operation, DC Coupling

5.4 Power Supply

The INS6310A operates from a 3.3V core supply and 3 independent 3.3V/2.5V output supplies.

VDD is INS6310A core supply voltage support 3.3V.

VDDOA, VDDOB and VDDOC are power supply for Bank A, B, C output buffers respectively. They can operate from 3.3V or 2.5V.

Notes

- V_{DDO} should be less than or equal to V_{DD} ($V_{DDO} \leq V_{DD}$)
 - .1uF or 0.01uF bypass capacitors should be placed very close to each supply pin
 - 1uF to 10uF Decoupling capacitors should be placed nearby
-

6 ENVIRONMENT

Table 16. ENVIRONMENT CONDITIONS

Parameters	Value	Unit	Notes
ESD Level	±2000V	V	HBM, Refer to ANSI/ESDA/JEDEC JS-001-2010
	±800V	V	CDM, Refer to JEDEC specification JESD22-C101

* HBM: Human body model

CDM: Charged-device model

7 PACKAGE OUTLINE

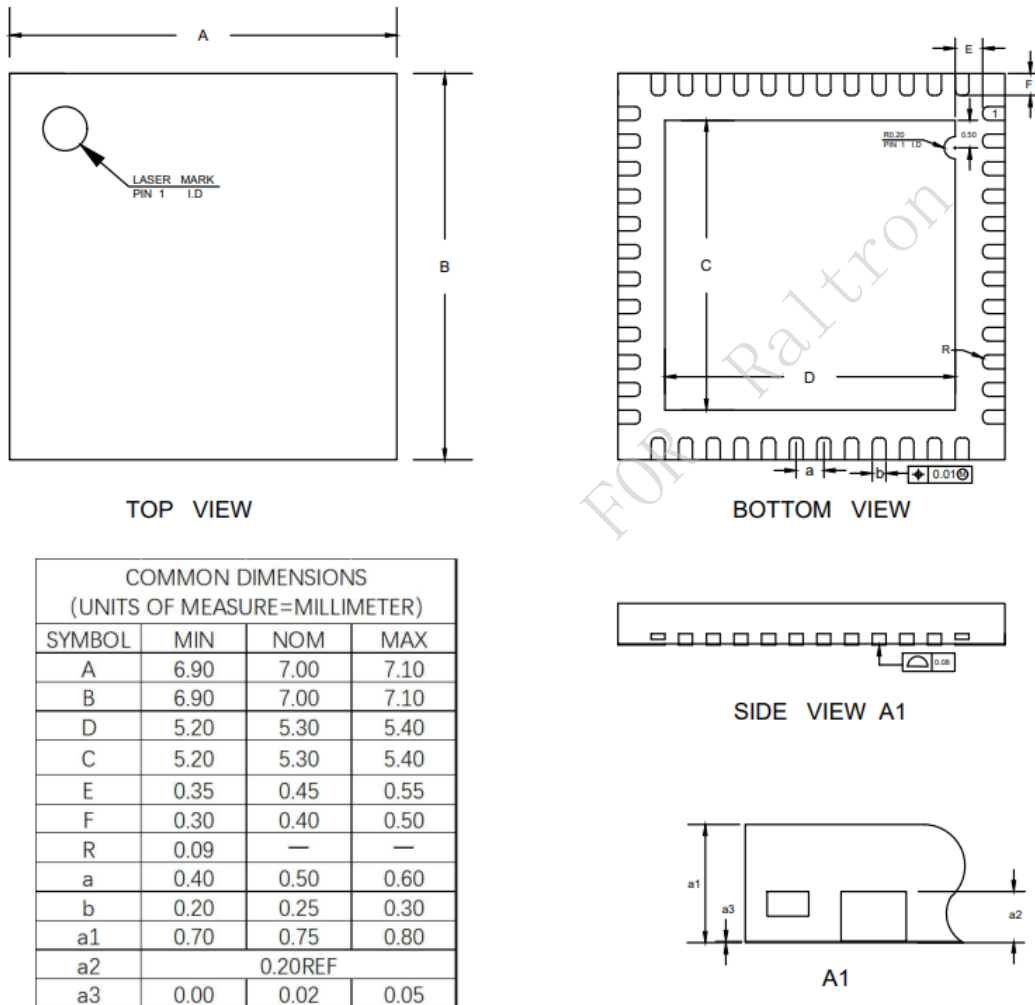

Figure 11. Package Outline Diagram