

INS6104A —1:4 Low Skew Clock Buffer

FEATURES

- Low skew outputs (50ps)
- Low power CMOS technology
- Operating Voltages of 3.3V/2.5V \pm 5%
- Output Enable pin tri-states outputs
- 3.6 V tolerant input clock
- Totally Lead-Free & Fully RoHS Compliant
- Halogen and Antimony Free. “Green” Device
- Industrial temperature range: -40°C to +85°C
- Packaged: 8-pin SOIC

APPLICATIONS

- Wireless BBU, RRU and Wired Communication
- Servers, Computing, PCI Express (PCIe)
- Switches, Routers, Line Cards, Timing Cards

GENERAL DESCRIPTIONS

The INS6104A is a low skew, single input to four output, clock buffer. Perfect for fanning out multiple clock outputs. The input clock is distributed to four LVCMOS outputs which can be enabled or disabled by OE pin. The INS6104A operates from a 3.3V/2.5V power supply.

Table of Amendment

Version	Revised Content	Draft	Revised Date
Preliminary	Preliminary version		2022.02.15

Table of Contents

1	GENERAL DESCRIPTION.....	4
2	FUNCTIONAL BLOCK DIAGRAM.....	4
3	PINOUTS.....	5
4	ELECTRICAL CHARACTERISTICS.....	5
5	FUNCTION DESCRIPTION.....	8
6	ENVIRONMENT.....	10
7	PACKAGE OUTLINE.....	10

DAPU Confidential

1 GENERAL DESCRIPTION

The INS6104A is a low skew, single input to four output, clock buffer. Perfect for fanning out multiple clock outputs. The input clock is distributed to four LVCMOS outputs which can be enabled or disabled by OE pin. The INS6104A operates from a 3.3V/2.5V power supply.

2 FUNCTIONAL BLOCK DIAGRAM

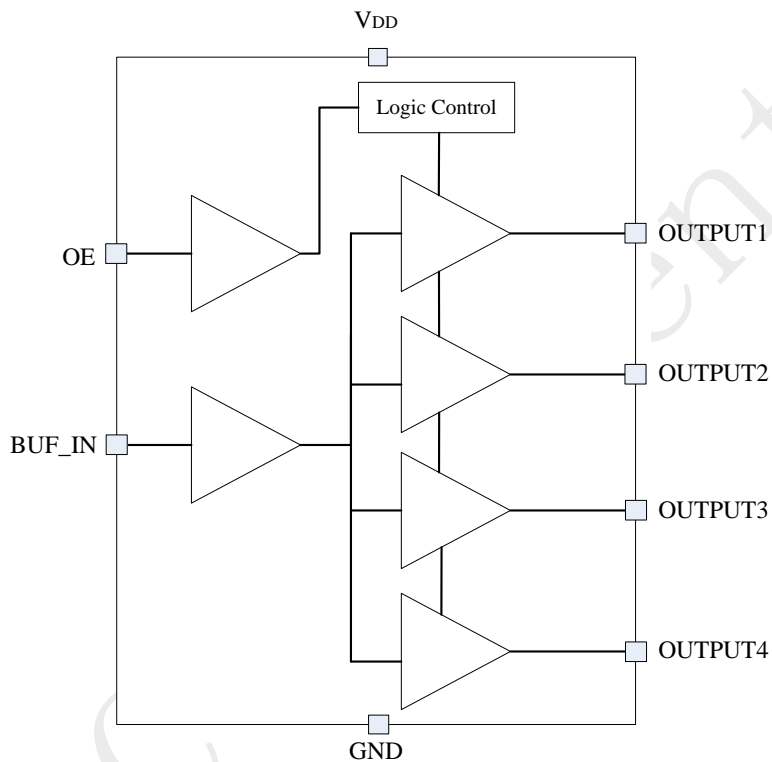

Figure 1. Block Diagram

3 PINOUTS

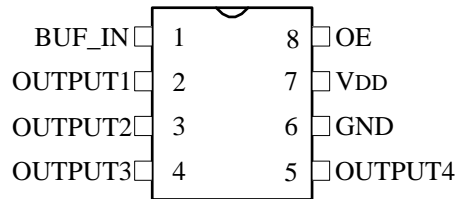

Figure 2. Pinouts Diagram

Table 1. Pin Definition

PIN No.	PIN Name	TYPE	DESCRIPTIONS
1	BUF_IN	IN	Clock Input. 3.3 V tolerant input.
2	OUTPUT1	OUT	Clock output 1
3	OUTPUT2	OUT	Clock output 2
4	OUTPUT3	OUT	Clock output 3
5	OUTPUT4	OUT	Clock output 4
6	GND	GND	Ground
7	V _{DD}	PWR	2.5V or 3.3V
8	OE	IN	Output Enable. Tri-states outputs when low. Connect to V _{DD} for normal operation.

4 ELECTRICAL CHARACTERISTICS

Table 2. Absolute Maximum Ratings

Stresses beyond those listed under absolute maximum ratings may cause permanent damage to the device. Exposure to absolute maximum rating conditions for extended periods may affect product reliability.

Parameter	Symbol	Rating	Unit
Power Supply	V _{DD}	-0.5~4.6	V
Input Voltage	V _{IN}	-0.5~V _{DD} +0.5	V
Output Voltage	V _{OUT}	-0.5~V _{DD} +0.5	V
Storage Temperature Range	T _{STG}	-65~150	°C
Maximum Junction Temperature	T _J	125	°C
Thermal Impedance	θ _{JA}	123	°C/W

Table 3. Recommended Operating Conditions

Test Condition: $-40^{\circ}\text{C} \leq T_A \leq 85^{\circ}\text{C}$; It is recommended that the chip operates with the rated electrical range indicated in the table below.

Parameter	Symbol	Value	Unit	Comments
-----------	--------	-------	------	----------

		Min.	Typ.	Max.		
Power Supply	V_{DD}	3.135	3.3	3.465	V	
		2.375	2.5	2.625		
Static Device Current	I_{VDD}		20		mA	$V_{DD}=3.3V$
Power dissipation capacitance per output	C_{PD}		9		pF	$V_{DD}=3.3V, F_{OUT}=100MHz$
Operating Temperature Range	T_A	-40		85	$^{\circ}C$	

Table 4. Control Signal Characteristics

Test Condition: $-40^{\circ}C \leq T_A \leq 85^{\circ}C$, $2.375V \leq V_{DD} \leq 3.465V$, $F_{IN/OUT}=100MHz$; Unless otherwise noted.

Parameter	Symbol	Value			Unit
		Min.	Typ.	Max.	
Control Signal (OE)					
Input High Current	I_{IH}			40	μA
Input Low Current	I_{IL}	-40			μA
Input High Voltage	V_{IH}	$0.7 \cdot V_{DD}$			V
Input Low Voltage	V_{IL}			$0.3 \cdot V_{DD}$	V

Table 5. BUF_IN Characteristics

Test Condition: $-40^{\circ}C \leq T_A \leq 85^{\circ}C$, $2.375V \leq V_{DD} \leq 3.465V$, Unless otherwise noted.

Parameter	Symbol	Value			Unit
		Min.	Typ.	Max.	
Frequency	F_{BUF_IN}			100	MHz
Input High Voltage	V_{BUF_INH}	$0.7 \cdot V_{DD}$		$V_{DD}+0.3$	V
Input Low Voltage	V_{BUF_INL}	-0.3		$0.3 \cdot V_{DD}$	V

Table 6. Output Characteristics

Test Condition: $-40^{\circ}C \leq T_A \leq 85^{\circ}C$, $2.375V \leq V_{DD} \leq 3.465V$, $F_{IN/OUT}=100MHz$, $C_L=5pF//50\Omega$; Unless otherwise noted.

Parameter	Symbol	Value			Unit	Comments
		Min.	Typ.	Max.		
Output High Voltage	V_{OH}	$0.8 \cdot V_{DD}$			V	$V_{DD}=2.375 \sim 3.465V$
Output High Voltage	V_{OL}			$0.2 \cdot V_{DD}$	V	$V_{DDOX}=2.375 \sim 3.465V$
Output impedance	R_O		15		Ω	$V_{DD}=3.3V$
			20		Ω	$V_{DD}=2.5V$
Output Frequency	F_{OUT}	0		100	MHz	
Duty Cycle	Duty Cycle	45	50	55	%	
Output Skew	$t_{skew}^{(*)}$		30	50	ps	
Part-to-part skew	$t_{PDP}^{(*)}$			2	ns	

Output Delay	t_{Delay}	1.5	1.95	4.0	ns	$V_{\text{DD}}=3.3\text{V}$
		1.8	2.4	4.4	ns	$V_{\text{DD}}=2.5\text{V}$
Rise/Fall Time	$t_{\text{Rise}}/t_{\text{Fall}}$		3.0		ns	$V_{\text{DD}}=3.3\text{V}$ $C_{\text{L}}=15\text{pF}$
			4.4		ns	$V_{\text{DD}}=3.3\text{V}$ $C_{\text{L}}=50\text{pF}$
			5.0		ns	$V_{\text{DD}}=3.3\text{V}$ $C_{\text{L}}=100\text{pF}$
Additive RMS Phase Jitter (RMS)	t_{J}		50		fs	$F_{\text{OUT}}=25\text{MHz}$ Input skew rate $\geq 2\text{V/ns}$ $C_{\text{L}}=5\text{pF}$ 12kHz to 20MHz
Output enable or disable time	t_{EN}			2	Cycle	

* Parameter is specified by design, not tested in production

5 FUNCTION DESCRIPTION

5.1 Control Signals

The outputs provide 4 LVCMOS copy of the input clock. The LVCMOS output high level is referenced to the V_{DD} voltage. The outputs can be enabled or disabled using the enable input pin, OE, as shown in Table 7.

Table 7. Reference Output Enable

OE	Outputs State
0	Hi-Z
1	Enabled

5.2 Input Clock

The BUF_IN input could be a LVCMOS clock up to 100MHz as shown in Figure 3. It is better to route the clock trace on the component side with a serial resistor close to the output pin ($\leq 200\text{mil}$).

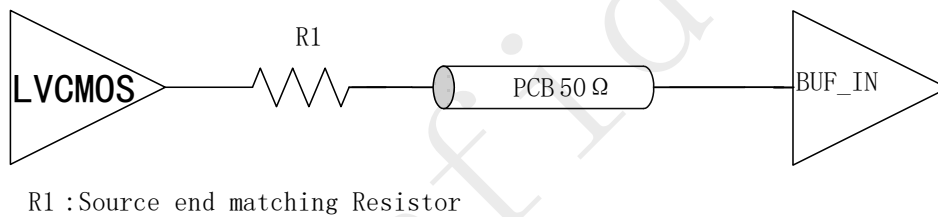

Figure 3. LVCMOS Input Clock

5.3 CLOCK OUTPUTS

INS6104A has 4 LVCMOS outputs OUTPUT1, OUTPUT2, OUTPUT3, OUTPUT4. A serial terminating resistor may be used on each clock output if the trace is longer than 1 inch.

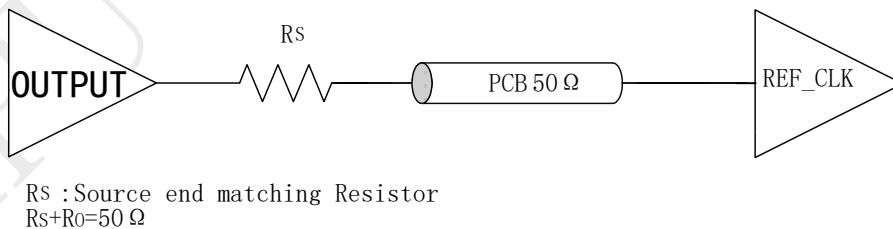

Figure 4. Output Termination

Table 8. Input Vs. Output States

Input Clock	Output State
BUF_IN= Logic High	Logic Low
BUF_IN= Logic Low	Logic High

Notes

- Unused outputs could be left floating to minimize capacitance. In this way, this output will consume minimal output current because it has no load.
-

5.4 Power Supply

V_{DD} is INS6104A power supply voltage support 3.3V and 2.5V.

Notes

- .1uF or 0.01uF bypass capacitors should be placed very close to each supply pin
 - 1uF to 10uF Decoupling capacitors should be placed nearby
-

6 ENVIRONMENT

Table 9. ENVIRONMENT CONDITIONS

Parameters	Value	Unit	Notes
ESD Level	±2000V	V	HBM, Refer to ANSI/ESDA/JEDEC JS-001-2010
	±800V	V	CDM, Refer to JEDEC specification JESD22-C101

* HBM: Human body model

CDM: Charged-device model

7 PACKAGE OUTLINE

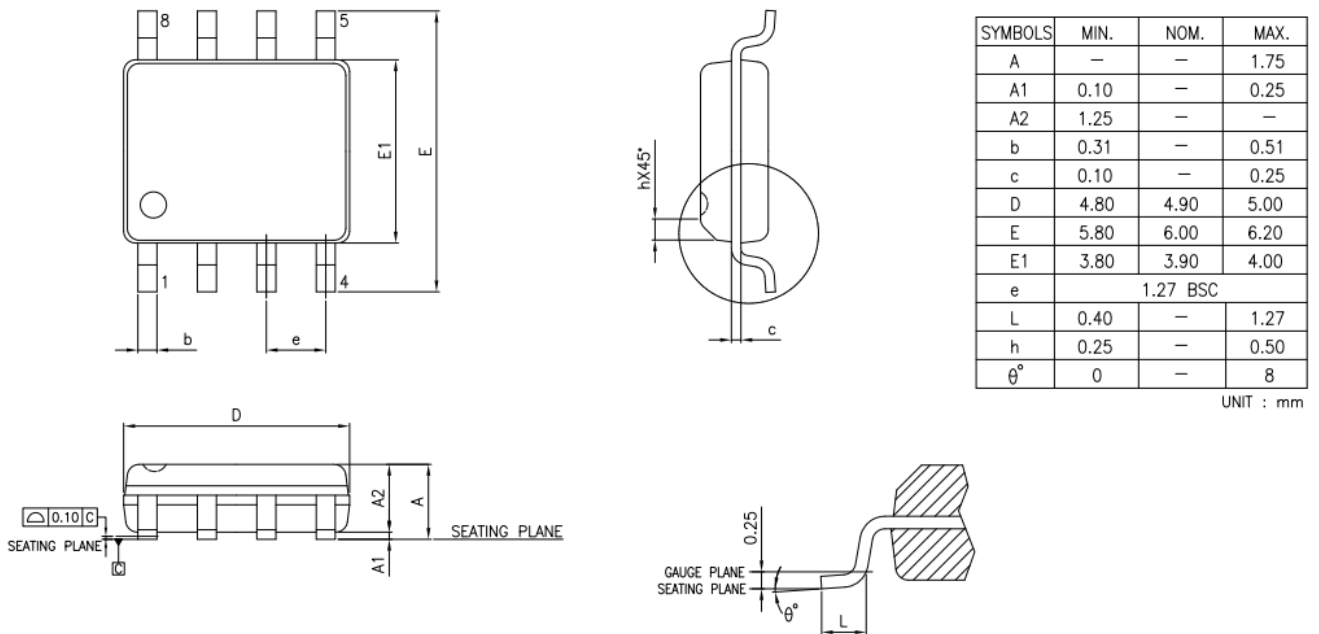

Figure 5. Package Outline Diagram