

Customer Code: _____

DATASHEET

DAPU P/N: **DP8W15625001**

DAPU			Customer Approval
Drew	Audited	Approved	Stamp, please! Thanks!
Date: 2017.12.11			

Guangdong Dapu Telecom Technology Co.,Ltd

Bldg 16,.N.Ind.Zone,SSL Industry Park, Dongguan City, Guangdong Province, China

TEL: 0086-0769-88010888 FAX: 0086-0769-81800098



1、Electrical Parameters

MODEL: DP8W15625001							
No.	Parameters	SYM.	Electrical Spec.				Notes
			Min.	Typ.	Max.	Units	
1	Nominal Frequency	FL	15.625			MHz	
2	Frequency Stability	-	-15	~	+15	$\times 10^{-6}$	-40°C~85°C
3	Operating Temperature	Topr	-40	~	+85	°C	
4	Supply Voltage	VDD	1.6	1.8	2.0	V	
5	Current Consumption	Icc		1.5		mA	
6	Output Load:	CL	15			pF	
7	Fan out type	LT	CMOS				
8	Output Voltage High	VoH	Vcc*0.9	-		V	
9	Output Voltage Low	Vol	-	-	Vcc*0.1	V	
10	Rise Time	Tr	-	-	6	ns	10%-90% VDD Level
11	Fall Time	Tf	-	-	6	ns	90%-10% VDD Level
12	Symmetry (Duty ratio)	TH/T	45	50	55	%	@50% Vcc
13	Output Enable Time				2	ms	
14	Standby Current				10	μA	
15	Phase Jitter				1	ps	RMS (12kHz to 5MHz)
16	RMS Period Jitter				2.4	ps	
17	Peak to peak Period Jitter				23	ps	
18	Enable Control		Yes				PIN1
19	Input Voltage High		Vcc*0.8			V	
20	Input Voltage Low				Vcc*0.2	V	
21	Output Prohibited Time				200	ns	
22	Phase Noise	Phase Noise		-134	-129	dBc/Hz	1KHz
23	ESD Level	Human Body Model,class2: 2000V to 4000V; ANSI/ESDA/JEDEC JS-001-2010.					
		Machine Model, class B: 200V to 400V; ANSI/ESDA/JEDEC JS-001-2010.					
24	Moisture Sensitivity Level	Level 2.					
25	Vibration	Test Condition: 0.75mm ;acceleration:10g;10Hz~2000Hz, one cycle per 30 min, test 2 hour. (3 times for each 3 directions X , Y , Z) .IEC 68-2-06 Test Fc.					
26	Shock	100g; 6ms; half sine wave (3 times for each 3 directions X , Y , Z) ,IEC 68-2-27 Test Ea/Severity 50A.					
27	Full Package Storage	Relative humidity (%)			20% ~ 70%		
		Temperature (°C)			-10~35°C		



2、Mechanical Structure(mm)

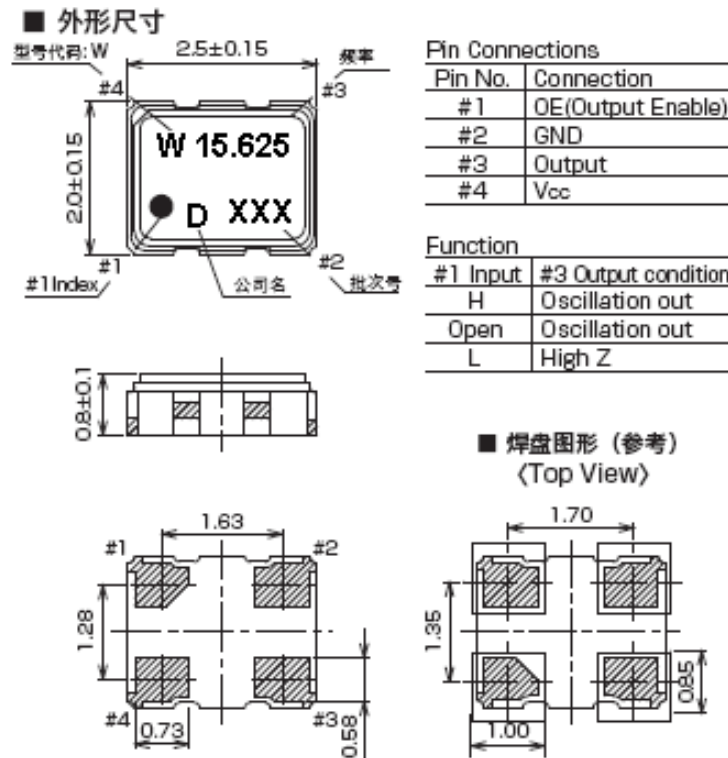

Note1: Tolerance $\pm 0.2\text{mm}$

Note2: The three xxx representative: lot number

3、Reflow Soldering Curve (RoHS)

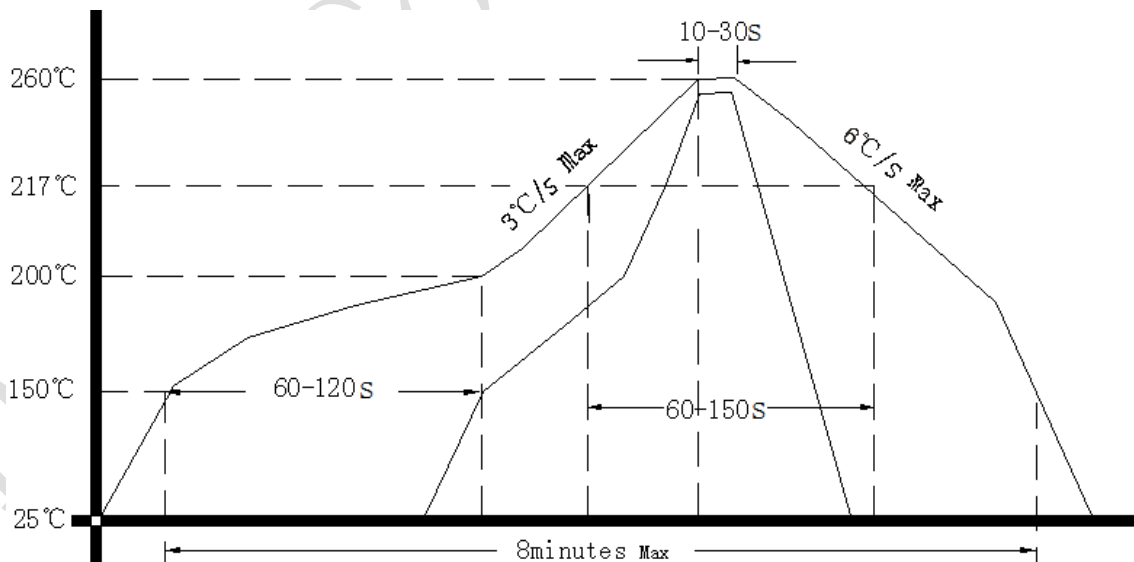



5、 Package: Tape & Reel (mm)

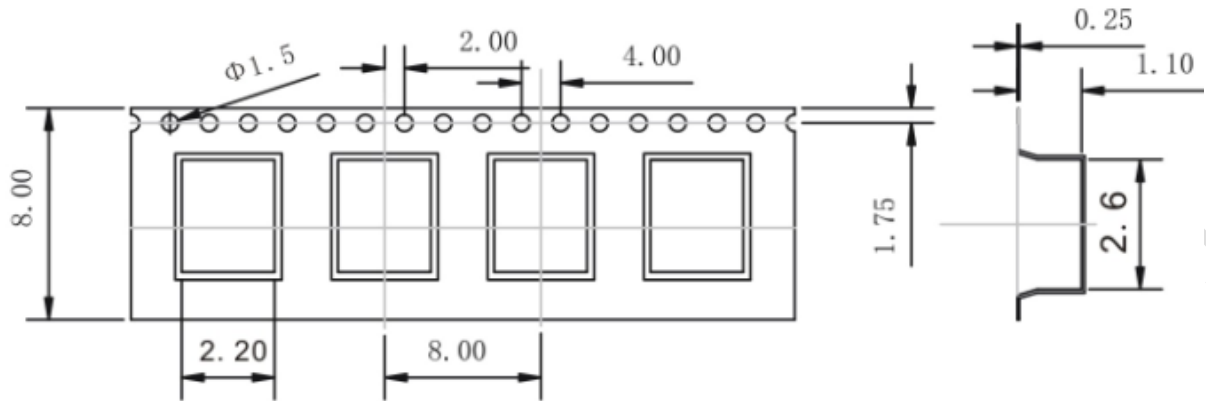

DAPU Confidential