

Customer Code :

DATASHEET

DAPU P/N: DPB32156M250AC0CNB0

Plot			The Label
Drew	Audited	Approved	Stamp, please! Thanks!
Lin Jianhua	David	William	
Date: 2024.03.15			

Guangdong Dapu Telecom Technology Co.,Ltd

Bldg 5, SSL Modern Enterprise Accelerator Zone, Dongguan City,
Guangdong Province, PRC China

TEL:0086-0769-88010888

FAX:0086-0769-81800098



1. Electrical characteristic

MODEL: DPB32156M250AC0CNB0

No.	Parameters	SYM.	Electrical Spec.				Notes
			Min.	Typ.	Max.	Units	
1	Nominal Frequency	FL	156.25			MHz	
2	Oscillation Mode	-	3rd			-	
3	Total Stability	-	-25		25	×10-6	Includes initial frequency tolerance, frequency temperature coefficient, frequency voltage coefficient, Output load, 5 year aging.
4	Operating Temperature	T-opr	-40		85	°C	
5	Storage Temperature	T-stg	-55		125	°C	
6	Supply Voltage	VDD	2.97	3.3	3.63	V	VDD±10%
7	Current Consumption	Idd			70	mA	ST = "H" or Floating, excluding load termination current.
		Idd_ST			10	uA	ST = "L"
8	Output waveform	-	LVPECL				
9	Output load	CL	50			Ω	Terminated to Vdd-2 V
10	Output Voltage High	VOH	Vcc-1.3		Vcc-0.9	V	
11	Output Voltage Low	VOL	Vcc-2.1		Vcc-1.7	V	
12	Rise/Fall Time	Tr/Tf			1	ns	@20%~80%
13	Aging	aging	-10		10	×10-6	At 25 °C, 10 years
14	Output Enable	-	VDD*0.7			V	For ST Pin
15	Output Disable	-			VDD*0.3	V	For ST Pin
16	Symmetry	SYM	45		55	%	
17	Start up time	T_str			10	ms	Measured from the time VDD reaches its rated minimum value.
18	RMS Jitter	Tpj			150	fs	12kHz to 20MHz



2. Machinal characteristic

2.1 Dimensions

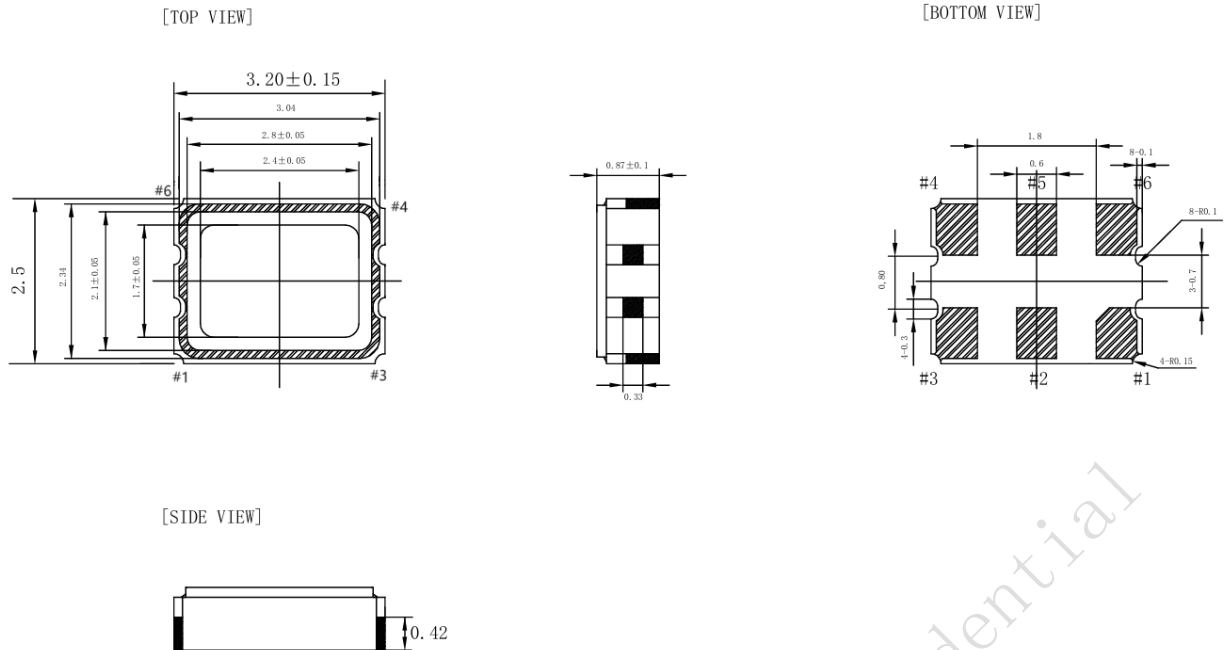

2.2 Pin Description

Pin	No	Function	
1	ST	INPUT	H or Open: Frequency Output
			L: Output is high impedance
2	NC	NA	No Connect: Leave it floating or connect to GND
3	GND	Power	Power Supply Ground
4	Q	Output	Oscillator Output
5	QN	Output	Complementary Oscillator Output
6	VDD	Power	Power Supply VDD

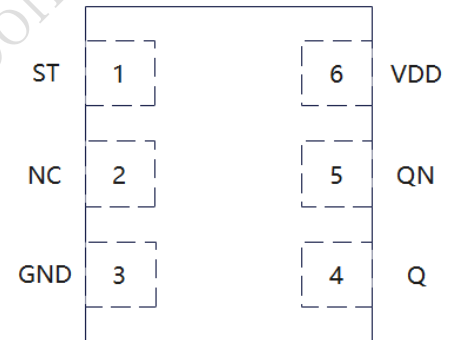

2.3 Marking

NO	Symbol	Function
1		DAPU LOGO
2	156.25	Frequency
3	YYWW	Manufactured day: YY: Year WW: Week
4	●	Pin 1





3. Waveform Diagrams

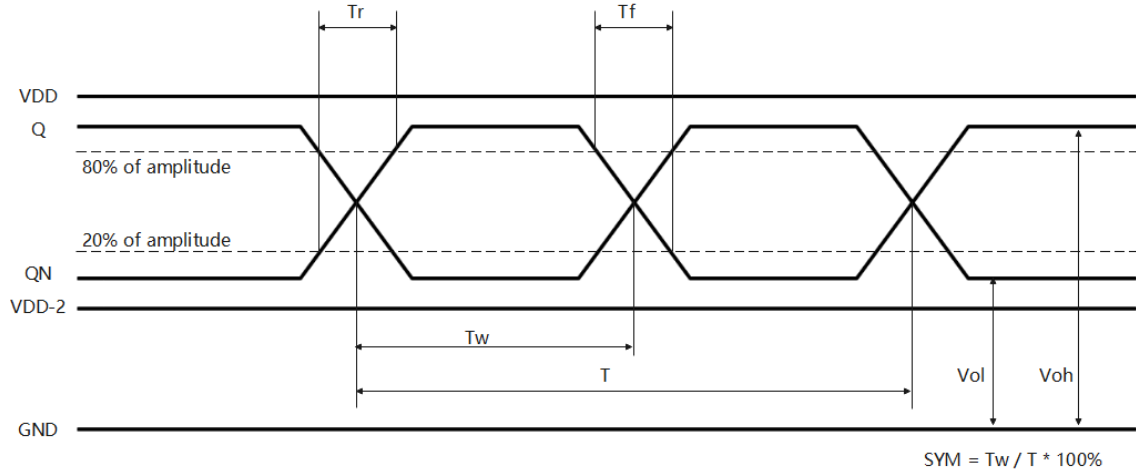

4. Termination Diagrams

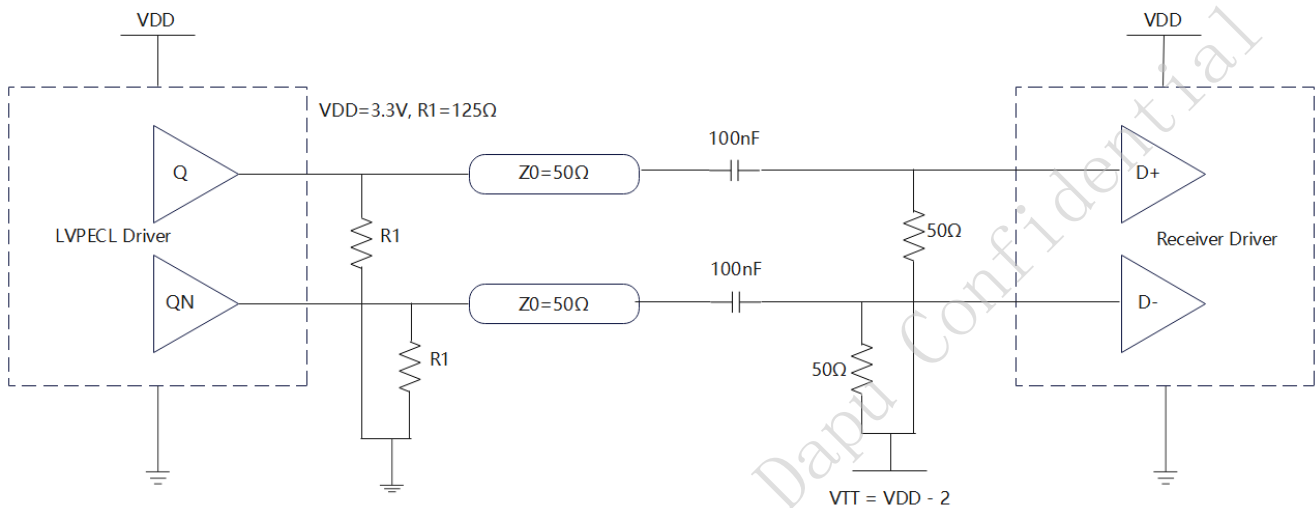

AC-Coupled LVPECL - VTT Bias

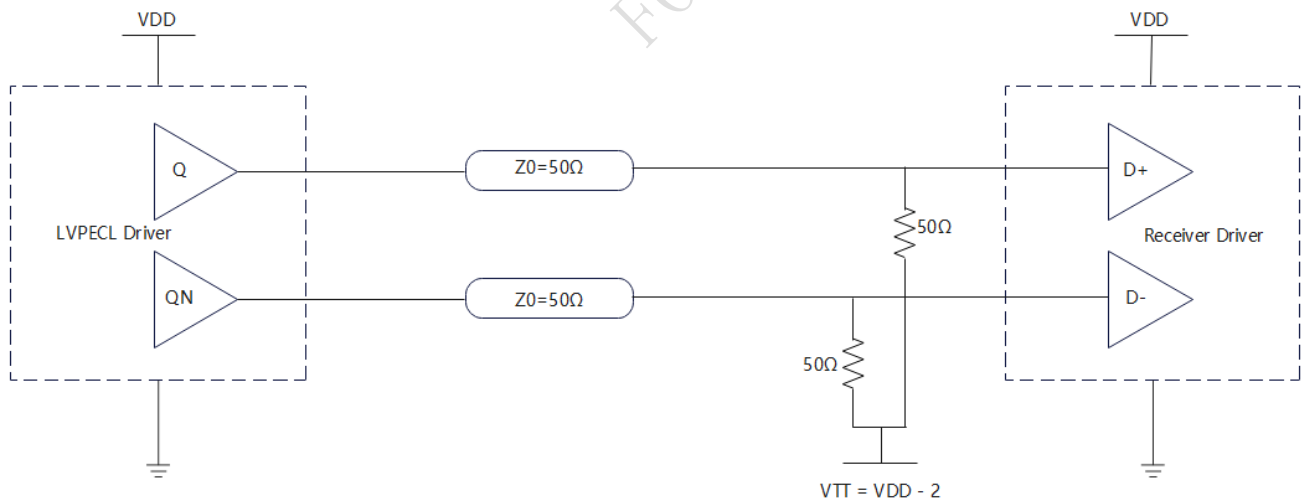

DC-Coupled LVPECL - VTT Bias

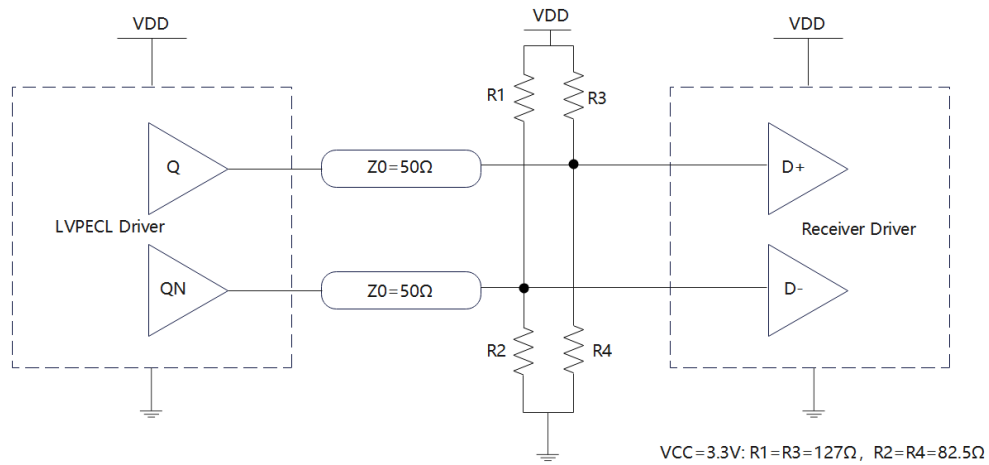

DC-Coupled LVPECL – Thevenin Termination

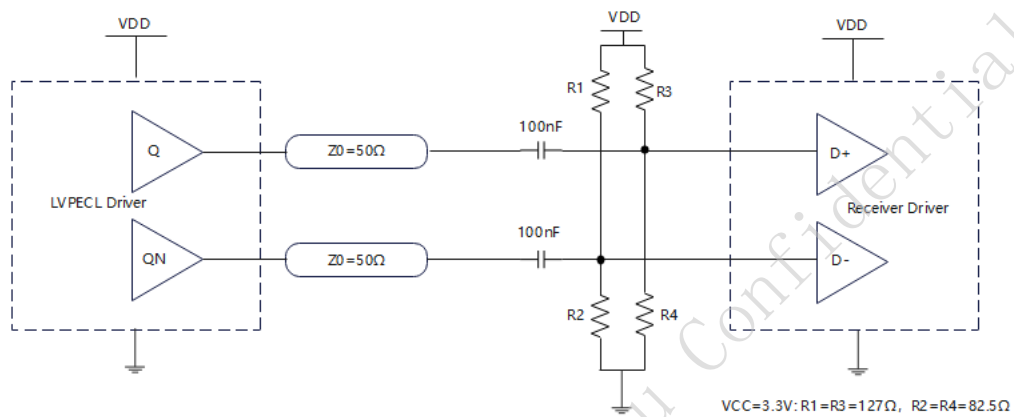

AC-Coupled LVPECL – Thevenin Termination

5. ESD

Table 1 ESD

Human Body Model (HBM)	2000V
Machine Model(MM)	200V

Reference Document: MIL-STD-883H



6. Solder Reflow Profile

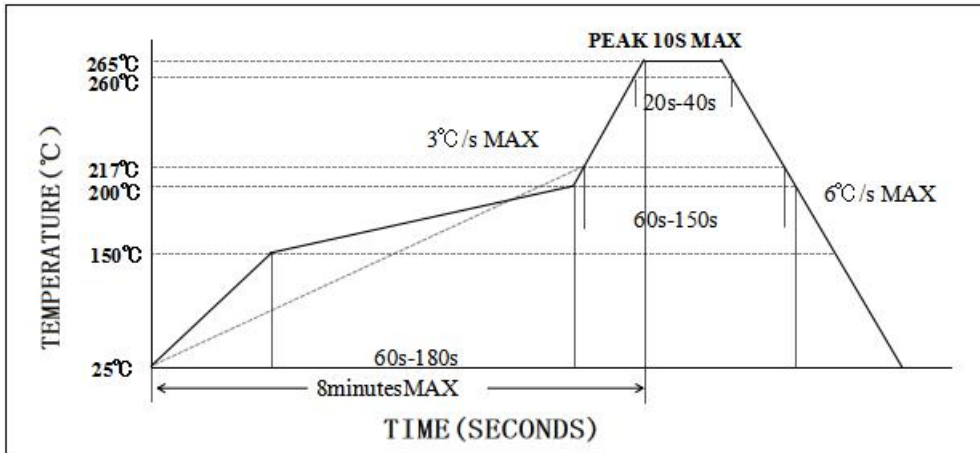

7. Package Outline Drawing

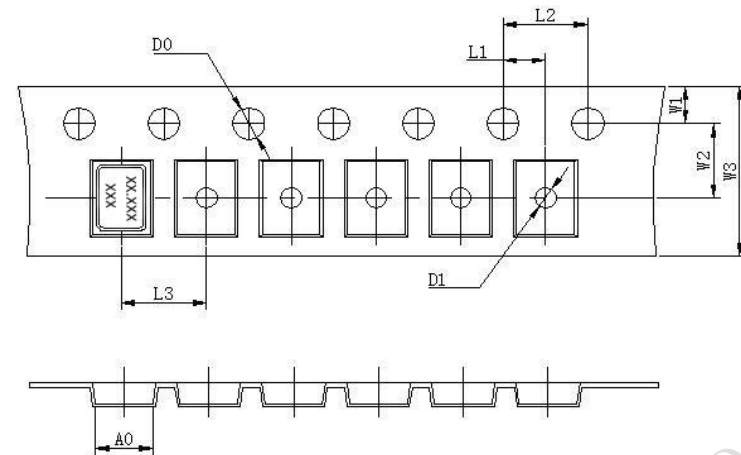

L1	2.00 ± 0.1
L2	4.00 ± 0.1
L3	4.00 ± 0.1
D0	1.55 ± 0.05
D1	1.20 ± 0.5
W1	1.75 ± 0.1
W2	3.50 ± 0.1
W3	8.00 ± 0.2
A0	2.25 ± 0.1
B0	2.7 ± 0.1
K0	1.45 ± 0.1
T	0.25 ± 0.05

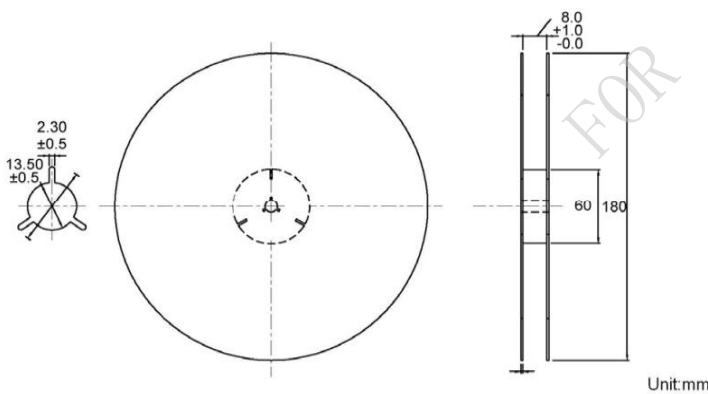



8. Reversion History

Version	Change Contents	Prepared by	Revised Date
V1.0	First issued	Lin Jianhua	2024.03.15

FOR Dapu Confidential