

Travelling Merchant: _____

DATASHEET

Standard: **T75B-P319-19.20MHz**

P/N: _____

Plot			The Label
Drew	Audited	Approved	Stamp, please! Thanks!
Date: 2012.08.22			

Guangdong Dapu Telecom Technology Co.,Ltd

Bldg13-16,.N.Ind.Zone,SSL Industry Park, Dongguan City, Guangdong Province, China

TEL: 0086-0769-88010888 FAX: 0086-0769-81800098



1. Electrical Parameters

MODEL: T75B-P319-19.20MHZ						
Item	Description	Parameters			Unit	Test Condition
		Min.	Typ.	Max.		
Output	Frequency	19.20			MHz	
	Output Waveform	HCMOS				
	Output Low Voltage			0.33	V	$V_{cc}=3.3V, O_{load}=15\text{ pF}$
	Output High Voltage	2.82			V	$V_{cc}=3.3V, O_{load}=15\text{ pF}$
	Duty Cycle	45	50	55	%	@50%
	Rise / Fall Time (10%~90%)			8	ns	@25°C
	Load	15			pF	
Frequency Stabilities	Frequency Tolerance vs. Operating Temperature Range	-0.28		+0.28	$\times 10^{-6}$	T_A varied from -40°C to 85°C, measurement referenced $(F_{MAX}+F_{MIN})/2$, temperature variable speed less than 2°C per minute.
	Initial Frequency Tolerance	-1		+1	$\times 10^{-6}$	Measurement referenced to frequency observed with $T_A=25^\circ\text{C}$, $V_{cc}=3.3V$, within 30 days after ex-works.
	Frequency Tolerance vs. Supply Voltage	-0.3		+0.3	$\times 10^{-6}$	measurement referenced to frequency observed $T_A=25^\circ\text{C}$, V_{cc} varied from 3.13V to 3.47V, and $O_{Load}=15\text{ pF}$.
	Frequency Tolerance vs. Load	-0.1		+0.1	$\times 10^{-6}$	10% load change measurement referenced to frequency observed with $T_A=25^\circ\text{C}$, $V_{cc}=3.3V, O_{Load}=15\text{ pF}$.
	Reflow Soldering (after 2 times reflow)	-1.5		+1.5	$\times 10^{-6}$	
	Aging 1 Year	-1		+1	$\times 10^{-6}$	$T_A=25^\circ\text{C}$, $V_{cc}=3.3V$, and after 1h of operation.
	Aging 10 Years	-3		+3	$\times 10^{-6}$	
	Drift(25±2°C),at constant V_s and V_c	-40		+40	$\times 10^{-9}$	
	Slope $\Delta F/\Delta T$ (25±2°C, at constant V_s and V_c)	-18		+18	$\times 10^{-9}/^\circ\text{C}$	
	All causes stability 20 years	-4.6		+4.6	$\times 10^{-6}$	



Power Supply	Current Consumption			7	mA	@25°C, V _{cc} =3.3V, O _{load} =15pF.
	Supply Voltage	3.13	3.3	3.47	V	
Phase Noise	Phase Noise		-90	-85	dBc/Hz	10Hz
			-115	-110		100Hz
			-130	-125		1KHz
			-140	-135		10KHz
			-145	-140		100KHz
Environmental Conditions	Operable Temperature	-40		+85	°C	
	Storage Temperature	-55		+105	°C	
	ESD Level	Human Body Model, class2: 2000V to 4000V; ANSI/ESDA/JEDEC JS-001-2010.				
		Machine Model, class B: 200V to 400V; ANSI/ESDA/JEDEC JS-001-2010.				
	Moisture Sensitivity Level	Level 2.				
	Vibration	IEC 60068-2-6 Test Fc, 10-60Hz 1.5mm displacement, at 98.0ms ⁻² , 30 minutes in each of three mutually perpendicular axes at 1 octave per minute.				
	Shock	IEC 60068-2-27 Test Ea, 980ms ⁻² , acceleration for 6ms duration 3 shocks in each direction along three mutually perpendicular axes.				
	Soldering	SMD product suitable for Convection Reflow soldering. Peak temperature 260°C. Maximum time above 220°C, 60secs.				
Solderability	MIL-STD-202, Method 208, Category 3.					
RoHS	Parts are fully compliant with the European Union directive 2002/95/EC on the restriction of the use of certain hazardous substances in electrical and electronic equipment. Note these RoHS compliant parts are suitable for assembly using both Lead-free solders and Tin/Lead solders.					



2. Mechanical Structure(mm)

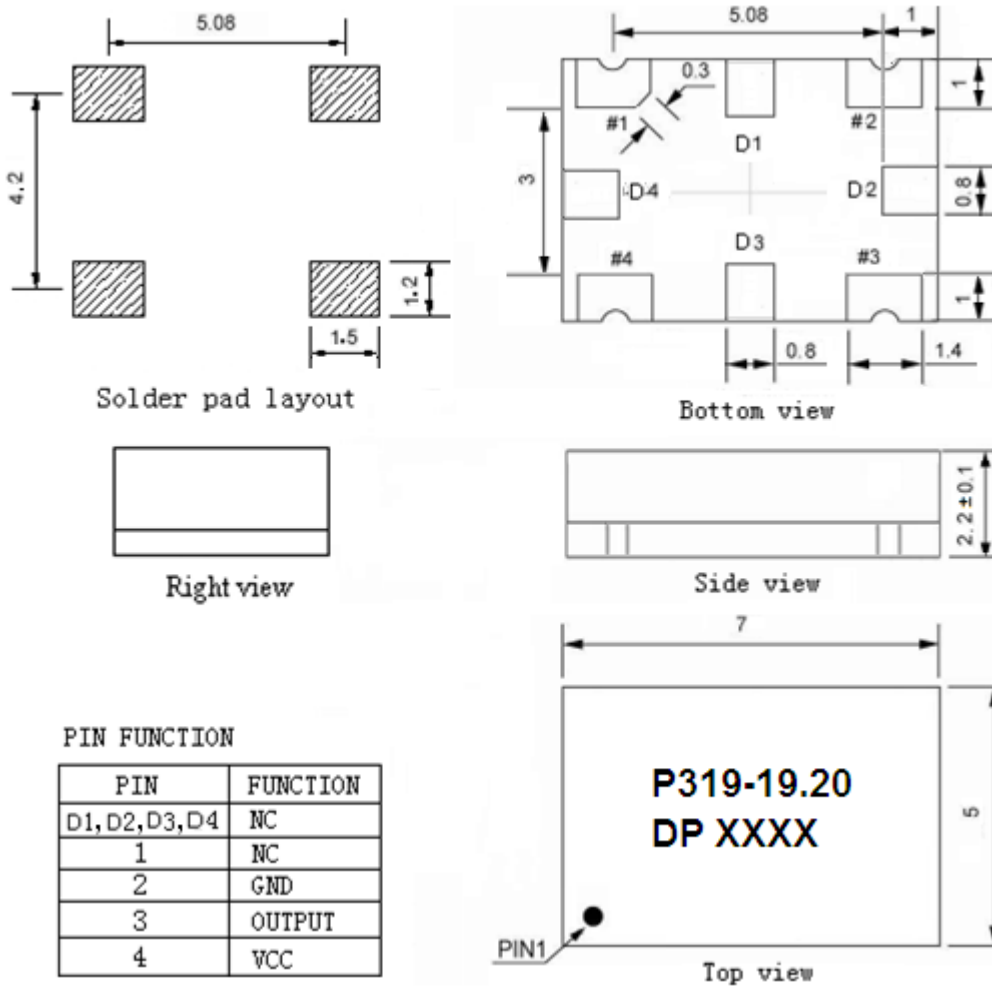

Note1: Tolerance $\pm 0.2\text{mm}$ without mark

Note2: The first two xx representative: week
After two xx representative: year

Note3: Referential Weight 0.2g

Note4: NC is not connect

3. Test circuit

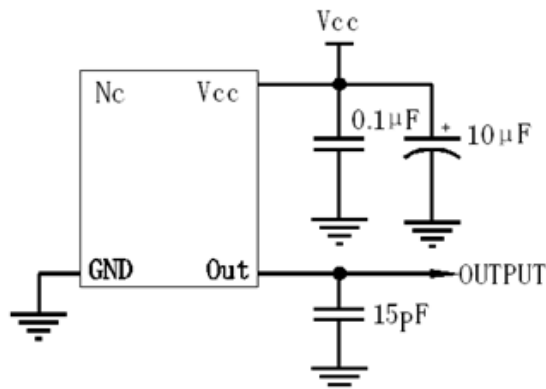



4. Reflow Soldering Curve (RoHS)

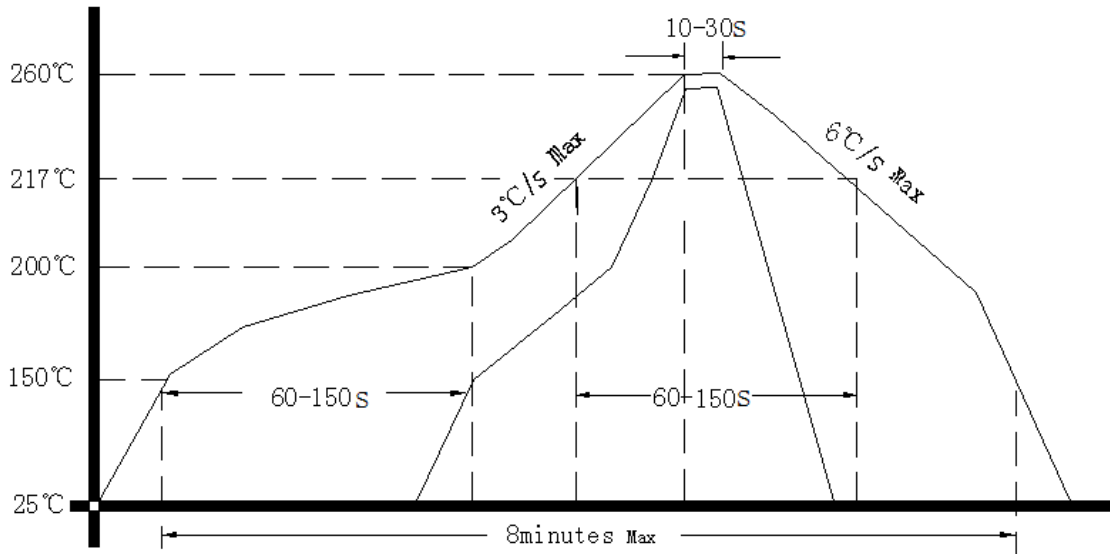

5. Package: Tape & Reel (mm)

