

Customer Code : _____

DATASHEET

DAPU P/N: T75B-H529-10.00MHz

Customer P/N: _____

DAPU			Customer Approval
Drew	Audited	Approved	Stamp, please! Thanks!
Date: 2018.02.06			

Guangdong Dapu Telecom Technology Co.,Ltd

Bldg 16,.N.Ind.Zone,SSL Industry Park, Dongguan City, Guangdong Province, China

TEL: 0086-0769-88010888 FAX: 0086-0769-81800098



Table of amendment

Version	Revision contents	Prepared by	Revised date
1.0	The first issued	<i>Amway</i>	2012.06.08
1.1	“Mechanical Structure” change	<i>Amway</i>	2013.08.16
1.2	“Mechanical Structure” change	<i>Amway</i>	2013.12.12
1.3	“Mechanical Structure” change	<i>Amway</i>	2014.03.27
1.4	“Frequency Tolerance vs. Operating Temperature Range”, “Nominal Frequency” and “Phase Noise” change	<i>Amway</i>	2014.06.10
1.5	“Start-up Time”, “Frequency Slope” and “Aging Tolerance 10 Years” add “Nominal Frequency” and “Phase Noise” change	<i>Amway</i>	2014.07.02
1.6	Modified the 1 st page “Ultra Sonic Cleaning” and “Full Package Storage” added	<i>Amway</i>	2015.07.31
1.7	“Full Package Storage” deleted	<i>Amway</i>	2015.08.05
1.8	Add “ultrasonic power” in “ultrasonic cleaning”	<i>Amway</i>	2018.02.06



1. Electrical Parameters

MODEL: T75B-H529-10.00MHz						
Item	Description	Parameters			Unit	Test Condition
		Min.	Typ.	Max.		
Output	Frequency	10.00			MHz	
	Output Waveform	Clipped Sine Wave				
	V _{p-p}	0.8			V	
	Load	10KΩ//10pF				
	Start-up Time			5	ms	
Frequency Stabilities	Frequency Tolerance vs. Operating Temperature Range	-1		+1	$\times 10^{-6}$	TA varied from -40°C to 85°C, measurement referenced to frequency observed with TA=25°C, V _{cc} =5.0V, O _{load} =10KΩ//10pF, temperature variable speed less than 2°C per minute.
	Initial Frequency Tolerance	-1		+1	$\times 10^{-6}$	Measurement referenced to frequency observed with T _A =25°C, V _{cc} =5.0V within 30 days after ex-works.
	Nominal Frequency Tolerance	-1.5		+1.5	$\times 10^{-6}$	Frequency at 25°C ± 2°C sixty minutes after reflow (compare 10.00MHz)
	Frequency Slope	-0.5		+0.5	$\times 10^{-6}/^{\circ}\text{C}$	Testing every 0.25°C, over -40°C to 85°C.
	Frequency Tolerance vs. Supply Voltage	-0.1		+0.1	$\times 10^{-6}$	Measurement referenced to frequency observed T _A =25°C, V _{cc} varied from 4.75V to 5.25V, and O _{Load} =10KΩ//10pF.
	Frequency Tolerance vs. Load	-0.2		+0.2	$\times 10^{-6}$	10% load change measurement referenced to frequency observed with T _A =25°C, V _{cc} =5.0V, O _{Load} =10KΩ//10pF.
	Short-Term Stability: Allan Variance			1	$\times 10^{-9}$	Temperature stability, no EMI/EMC or other interference, test after power for 1 hour ref. to 25°C; 1s, using PN9000 equipment.
	Aging Tolerance Per Day	-0.02		+0.02	$\times 10^{-6}$	T _A =25°C, V _{cc} =5.0V, and after 1h of operation.
	Aging Tolerance 1 Year	-1		+1	$\times 10^{-6}$	
	Aging Tolerance 10 Years	-5		+5	$\times 10^{-6}$	
Power Supply	Current Consumption			2	mA	@25°C, V _{cc} =5.0V, O _{load} =10KΩ//10pF.
	Supply Voltage	4.75	5.0	5.25	V	



Phase Noise	Phase Noise		-93	-89	dBc/Hz	10Hz
			-121	-118		100Hz
			-141	-137		1KHz
			-150	-145		10KHz
			-152	-149		100KHz
			-152	-151		1MHz
Environmental Conditions	Operable Temperature	-40		+85	°C	
	Storage Temperature	-55		+125	°C	
	ESD Level	Human Body Model, class2: 2000V to 4000V; ANSI/ESDA/JEDEC JS-001-2010.				
		Machine Model, class B: 200V to 400V; ANSI/ESDA/JEDEC JS-001-2010.				
	Moisture Sensitivity Level	Level 2.				
	Vibration	Test Condition: 0.75mm ;acceleration:10g;10Hz~2000Hz, one cycle per 30 min, test 2 hours. (3 times for each 3 directions X , Y , Z) .IEC 68-2-06 Test Fc.				
	Shock	100g; 6ms; half sine wave (3 times for each 3 directions X , Y, Z),IEC 68-2-27 Test Ea/Severity 50A.				
Ultra Sonic Cleaning	Cleaning equipment frequency: 40KHz; Cleaning solvent: bromopropane; Cleaning time: 15 min. per each time, at least 3 times; ultrasonic power:1200w.					



2. Mechanical Structure(mm)

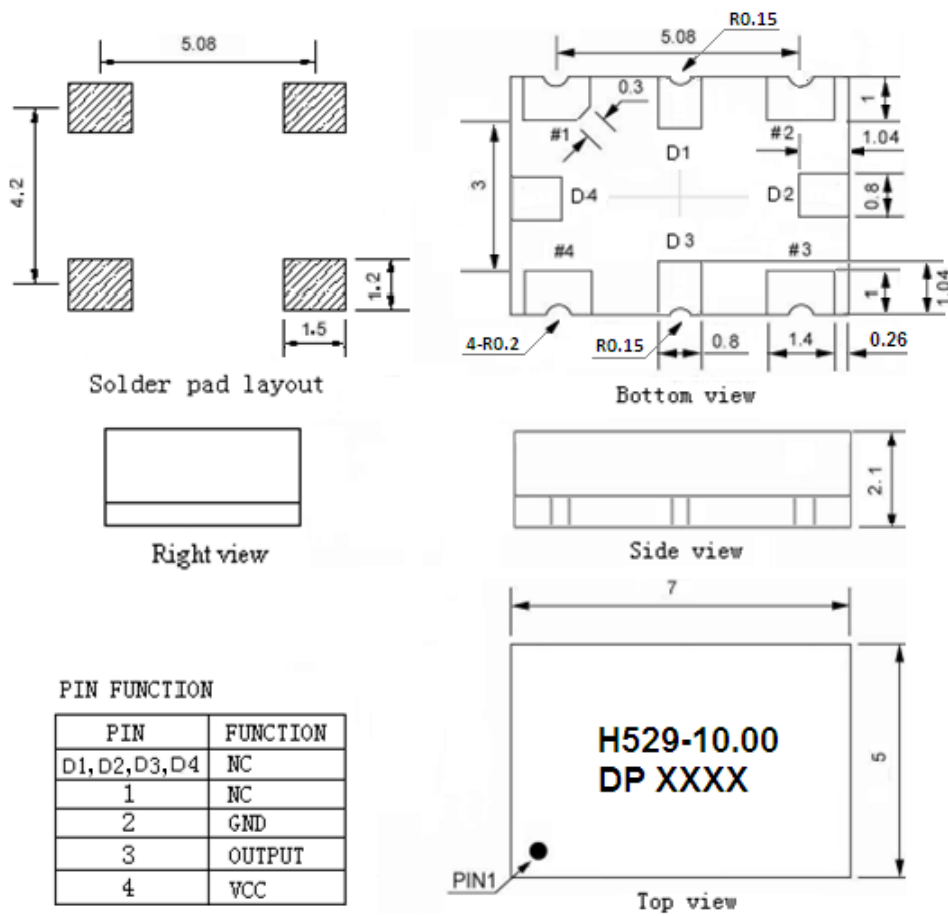

Note1: Tolerance ± 0.2 mm without mark

Note2: The first two xx representative: week
After two xx representative: year

Note3: Referential weight 0.2g

Note4: NC is not connect



3. Test circuit

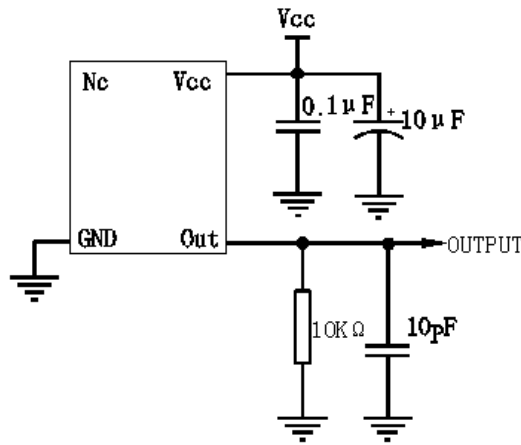

4. Reflow Soldering Curve (RoHS)

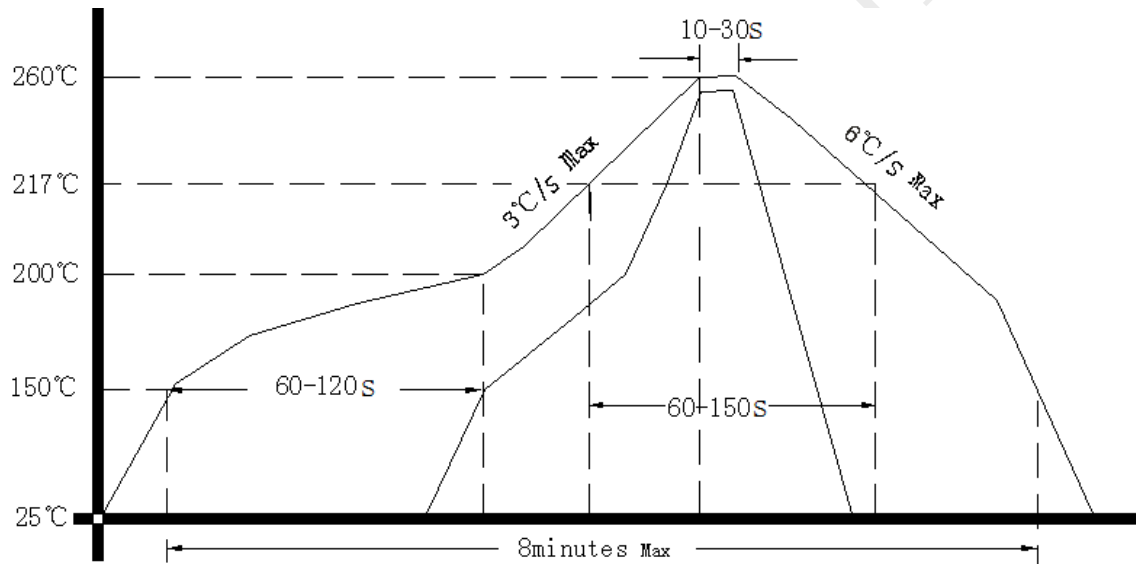

5. Package: Tape & Reel (mm)

