

Customer Code : _____

DATASHEET

DAPU P/N: **T53-F313-19.20MHz**

Customer P/N: _____

DAPU			Customer Approval
Drew	Audited	Approved	Stamp, please! Thanks!
Date: 2021.09.15			

Guangdong Dapu Telecom Technology Co.,Ltd

Building 5, No.24, Industrial East Road, Songshanhu Park, Dongguan, Guangdong, P.R. China

TEL: 0086-0769-88010888 FAX: 0086-0769-81800098



1. Electrical Parameters

MODEL: T53-F313-19.20MHz						
Item	Description	Parameters			Unit	Test Condition
		Min.	Typ.	Max.		
Output	Frequency	19.20			MHz	
	Output Waveform	HCMOS				
	Output Low Voltage			0.1V _{cc}	V	V _{cc} =3.3V, O _{load} =15 pF
	Output High Voltage	0.9V _{cc}			V	V _{cc} =3.3V, O _{load} =15 pF
	Duty Cycle	45	50	55	%	@50%
	Rise / Fall Time (10%~90%)			8	ns	@25°C
	Load	15			pF	
Frequency Stabilities	Frequency Tolerance vs. Operating Temperature Range	-0.5		+0.5	× 10 ⁻⁶	T _A varied from -40°C to 85°C, measurement referenced to frequency observed with T _A =25°C, V _{cc} = 3.3V, V _c =1.65V, O _{load} =15pF, temperature variable speed less than 2°C per minute.
	Initial Frequency Tolerance	-1		+1	× 10 ⁻⁶	Measurement referenced to frequency observed with T _A =25°C, V _{cc} =3.3V, V _c =1.65V within 30 days after ex-works.
	Frequency Tolerance vs. Supply Voltage	-0.2		+0.2	× 10 ⁻⁶	measurement referenced to frequency observed T _A =25°C, V _{cc} varied from 3.13V to 3.47V, V _c =1.65V and O _{Load} = 15pF .
	Frequency Tolerance vs. Load	-0.2		+0.2	× 10 ⁻⁶	10% load change measurement referenced to frequency observed with T _A = 25°C, V _{cc} =3.3V, V _c =1.65V, O _{Load} = 15pF
	Aging Tolerance Per Day	-0.02		+0.02	× 10 ⁻⁶	T _A =25°C, V _{cc} =3.3V, V _c =1.65V and after 1h of operation.
	Aging Tolerance 1 Year	-1		+1	× 10 ⁻⁶	
Power Supply	Current Consumption			6	mA	@25°C, V _{cc} =3.3V, V _c =1.65V, O _{load} =15pF.
	Supply Voltage	3.13	3.3	3.47	V	



Voltage Control Characteristics	Frequency Tuning Range			-10	$\times 10^{-6}$	$V_c=0$ V. measurement referenced to $V_c=1.65$ V.
		-1		+1	$\times 10^{-6}$	$V_c=1.65$ V. measurement referenced to Exactly 19.20MHz.
		+10			$\times 10^{-6}$	$V_c=3.3$ V. measurement referenced to $V_c=1.65$ V.
	Linearity			10	%	
	Slope	Positive				
	Input Impedance	100				K Ω
Phase Noise	Phase Noise		-85	-80	dBc/Hz	10Hz
			-115	-110		100Hz
			-135	-130		1KHz
			-145	-140		10KHz
			-150	-145		100KHz
			-150	-145		1MHz
Environmental Conditions	Operable Temperature	-40		+85	$^{\circ}$ C	
	Storage Temperature	-55		+105	$^{\circ}$ C	
	ESD Level	Human Body Model,class2: 2000V to 4000V; ANSI/ESDA/JEDEC JS-001-2010.				
		Machine Model, class B: 200V to 400V; JEDEC JESD22-A115C .				
	Moisture Sensitivity Level	Level 2.				
	Vibration	Test Condition: 0.75mm ;acceleration:10g;10Hz~2000Hz, one cycle per 30 min, test 2 hour. (3 times for each 3 directions X ,Y , Z) .IEC 68-2-06 Test Fc.				
Shock	100g; 6ms; half sine wave (3 times for each 3 directions X ,Y , Z),IEC 68-2-27 Test Ea/Severity 50A.					
Full Package Storage	Relative humidity (%)	20%~70%				
	Temperature ($^{\circ}$ C)	-10~35 $^{\circ}$ C				



2. Mechanical Structure(mm)

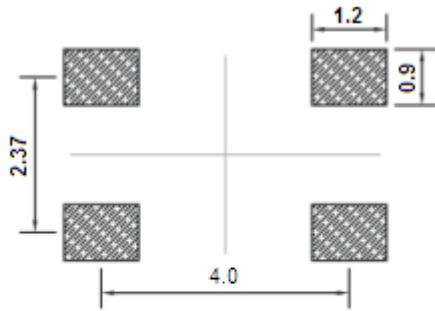

Solder pad layout

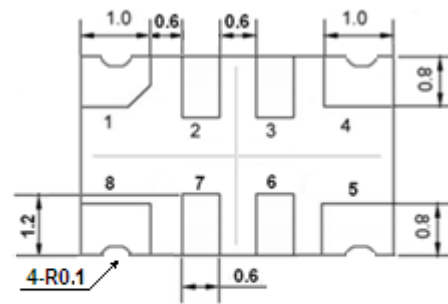

Bottom view

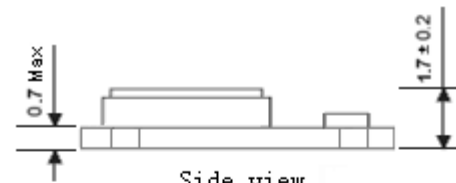

Side view

PIN FUNCTION

PIN	NOTATION	FUNCTION
1	VC	Control Voltage
2,3	NC	Not Connect
4	GND	GND
5	OUTPUT	RF Output
6,7	NC	Not Connect
8	VCC	Supply Voltage

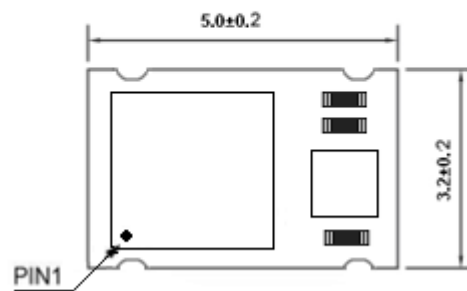

Top view

Note1: Tolerance $\pm 0.20\text{mm}$ without mark

Note2: Referential weight 0.05g

Note3: NC is not connect

3. Test circuit

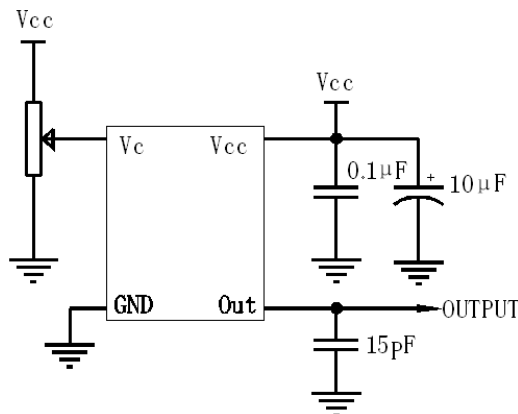



4. Reflow Soldering Curve (RoHS)

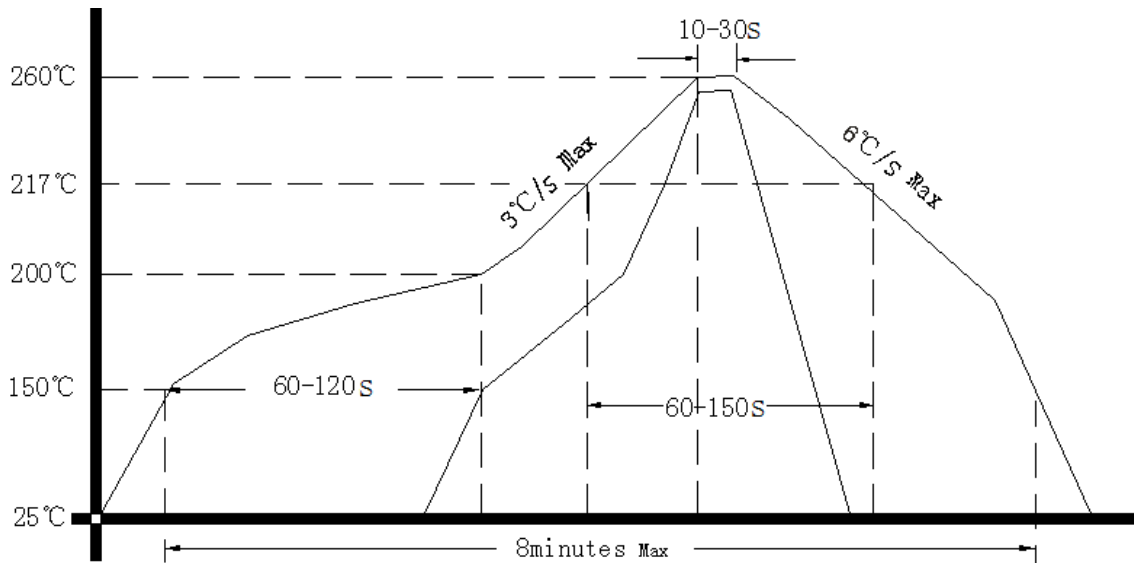

Note: If soldering with a hot air gun, ensure the temperature <320°C , soldering time <15 seconds.

5. Package: Tape & Reel (mm)

