

Travelling Merchant: _____

DATASHEET

Standard: **T21-K573-38.40MHz**

Plot			The Label
Drew	Audited	Approved	Stamp, please! Thanks!
Date: 2023.10.12			

Guangdong Dapu Telecom Technology Co.,Ltd

Building 5, No.24, Industrial East Road, Songshanhu Park, Dongguan, Guangdong, P.R. China

TEL: 0086-0769-88010888 FAX: 0086-0769-81800098



1、 Electrical Parameters

MODEL: T21-K573-38.40MHz								
No.	Parameters		SYM.	Electrical Spec.				Notes
				Min.	Typ.	Max.	Units	
1	Nominal Frequency		F0	38.40			MHz	
2	Supply Voltage		Vcc	1.71	1.8	1.89	V	
3	Current consumption		-	-	-	2	mA	
4	Output Level		-	0.8	-	-	Vp-p	
5	Output Waveform		-	Clipped Sine wave			-	
6	Standard Output Load		-	9	10	11	KΩ//pF	
7	Frequency Stability	vs.Tolerance	-	-2	-	+2	$\times 10^{-6}$	at +25°C+/-2°C,2H,After 2 times reflow soldering, based on Nominal Frequency, at control voltage (Vcont)=0.9VDC
8		vs. Temperature	-	-2	-	+2	$\times 10^{-6}$	-30~+85°C Based on Frequency at +25°C+/-2°C) at control voltage(Vcont)=0.9VDC
9		vs. Long-term	-	-1	-	+1	$\times 10^{-6}$	First year
10		vs. Load	-	-0.2	-	+0.2	$\times 10^{-6}$	Load:10KΩ//10pF , ±5% each
11		vs. Supply Voltage	-	-0.2	-	+0.2	$\times 10^{-6}$	+1.8V ±5%
12	Control voltage(Vcont)			0	0.9	1.8	V	
13	Frequency control range			-10		-7	$\times 10^{-6}$	Vcont=0V,based on frequency at Vcont=0.9VDC
14				+7		+10	$\times 10^{-6}$	Vcont=1.8V,based on frequency at Vcont=0.9VDC
15	Frequency changed polarity			Positive				
16	Operating Temperature Range		-	-30	~	+85	°C	
17	Storage Temperature		-	-40	~	+90	°C	
18	Start Up Time		-	-	-	2.0	ms	@90% of final Vout level
19	Phase Noise(at 25°C)				-130		dBc/Hz	1KHz



2、Mechanical Structure(mm)

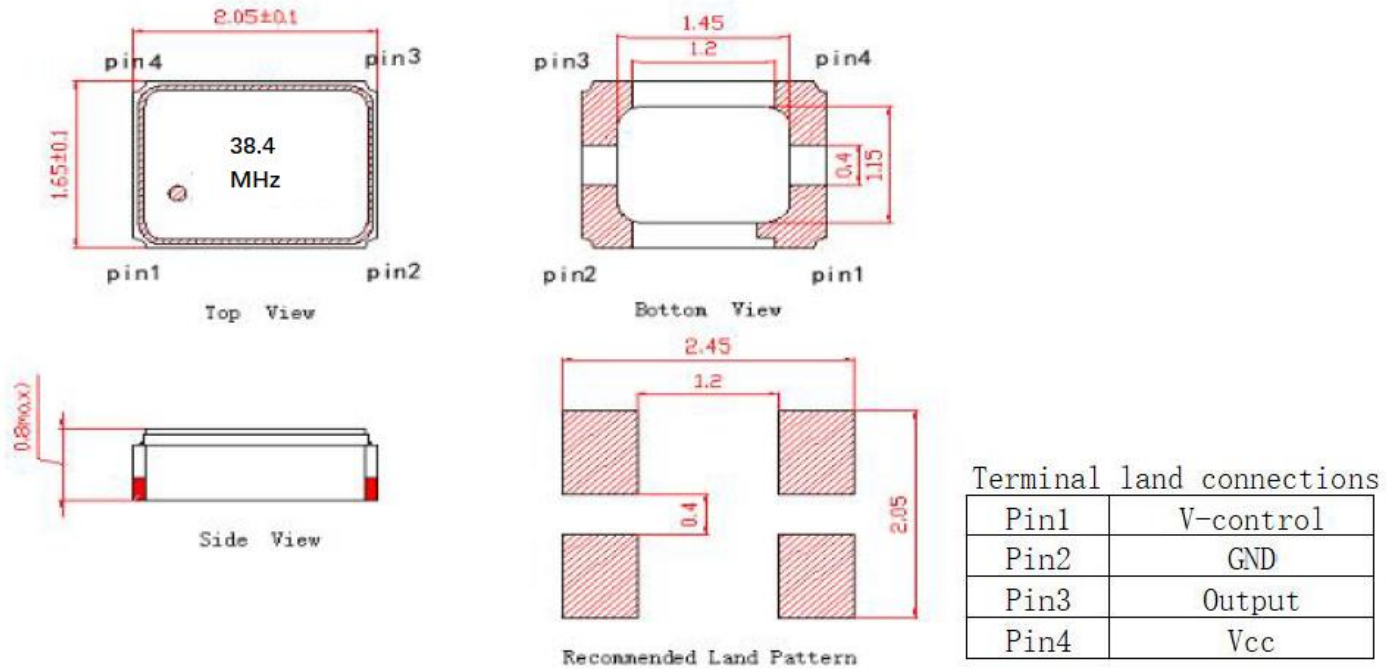

Note1: Tolerance ± 0.2 mm

3、Reflow Soldering Curve (RoHS)

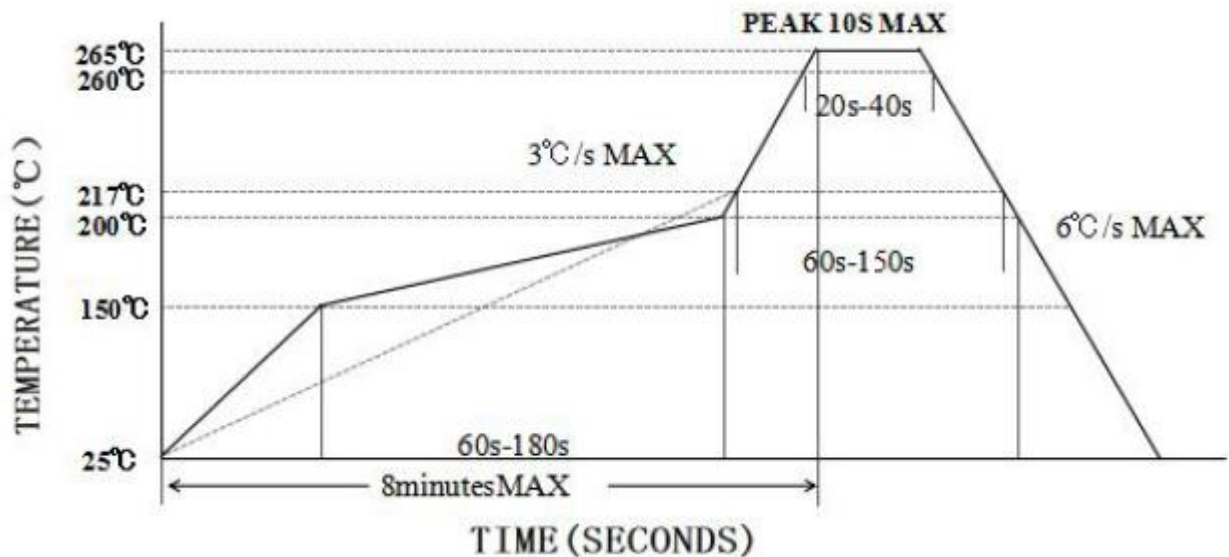



4、 Packing(mm)

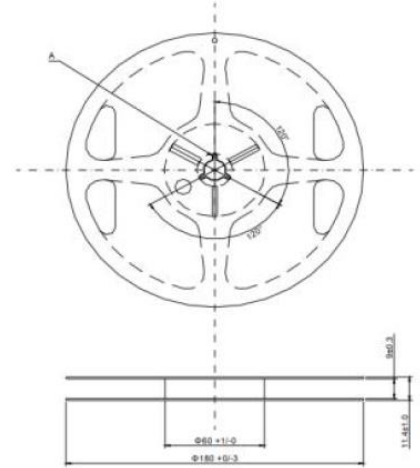
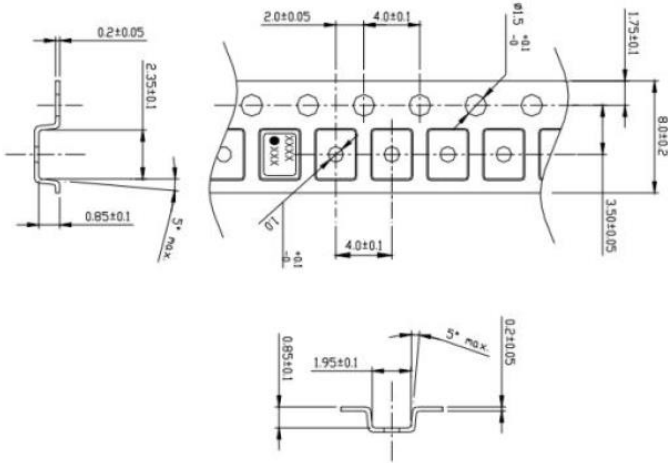

1. Clearance of an embossing tape, and a product unit: mm

Direction	Pocket size	TCXO size	Clearance
L	2.35±0.10	2.00±0.15	0.35±0.25
W	1.95±0.10	1.60±0.15	0.35±0.25
H	0.85±0.05	0.70±0.10	0.15±0.15

2. Quality : Polystyrene (Conductivity)
3. Tensile strength of an embossing tape : more than 14N

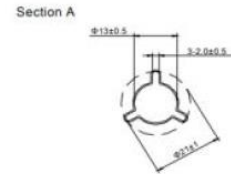

Material: Polystyrene (Conductivity)
unit:mm