

Customer Code : _____

DATASHEET

DAPU P/N: **079A-M319-20.00MHz-G007**

Customer P/N: _____

DAPU			Customer Approval
Drew	Audited	Approved	Stamp, please! Thanks!
Date: 2023.03.09			

Guangdong Dapu Telecom Technology Co.,Ltd

Building 5, No.24, Industrial East Road, Songshanhu Park, Dongguan, Guangdong, P.R. China

TEL: 0086-0769-88010888 FAX: 0086-0769-81800098



1. Electrical Parameters

MODEL: O79A-M319-20.00MHZ-G007						
Item	Description	Parameters			Unit	Test Condition
		Min.	Typ.	Max.		
Output	Frequency	20.00			MHz	
	Output Waveform	HCMOS				
	Output Low Voltage			0.4	V	$V_{cc}=3.3V, O_{load}=15pF$
	Output High Voltage	2.4			V	$V_{cc}=3.3V, O_{load}=15pF$
	Duty Cycle	45	50	55	%	@50%
	Rise / Fall Time (10%~90%)			4	ns	
	Load	15			pF	
Frequency Stabilities	Frequency Tolerance vs. Operating Temperature Range	-0.02		+0.02	$\times 10^{-6}$	T_A varied from $-40^{\circ}C$ to $85^{\circ}C$, measurement referenced to frequency observed with $f_{ref}=(f_{max}+f_{min})/2$, $V_{cc}=3.3V, O_{load}=15pF$, temperature variable speed less than $2^{\circ}C$ per minute.
	Initial Frequency Tolerance	-1		+1	$\times 10^{-6}$	Measurement referenced to frequency observed with $T_A=25^{\circ}C, V_{cc}=3.3V$, and after 15 minutes of operation, within 30 days after ex-works.
	Frequency Tolerance vs. Supply Voltage	-0.01		+0.01	$\times 10^{-6}$	Measurement referenced to frequency observed $T_A=25^{\circ}C, V_{cc}$ varied from 3.13V to 3.47V, and $O_{Load}=15pF$.
	Frequency Tolerance vs. Load	-0.01		+0.01	$\times 10^{-6}$	5% load change measurement referenced to frequency observed with $T_A=25^{\circ}C, V_{cc}=3.3V, O_{Load}=15pF$.
	Short-Term Stability: Allan Variance		0.03		$\times 10^{-9}$	Temperature stability, no EMI\EMC or other interference, test after power for 1hour ref. to $25^{\circ}C; 0.1s$.
	Reflow Shift	-0.5		+0.5	$\times 10^{-6}$	After 1 hour recovery.
	Slope	-1		+1	$\times 10^{-9}/^{\circ}C$	$T_A=25^{\circ}C$, temperature ramp $0.5^{\circ}C/minute$.
	Aging Tolerance Per Day	-3		+3	$\times 10^{-9}$	V_{cc}, T_A constant measurement referenced to frequency observed with $T_A=25^{\circ}C, V_{cc}=3.3V$, and after 30 days of operation.
	Aging Tolerance First Year	-0.5		+0.5	$\times 10^{-6}$	
	Aging Tolerance 20 Years	-3		+3	$\times 10^{-6}$	
	Holdover 24 hours Drift	-3		+3	$\times 10^{-9}$	



	Overall Stability	-4.6		+4.6	$\times 10^{-6}$	Inclusive of the following: - operating temperature -40°C to 85°C - $3.3\text{V}\pm 5\%$, - 15pF load $\pm 5\%$, - 2 times reflow soldering, - 20 years aging reference to nominal frequency.
Power Supply	Supply Voltage	3.13	3.3	3.47	V	
	Steady Consumption			250	mA	@ 25°C
	Warm up current			600	mA	
	Warm-up Time			3	minute	@ 25°C within $\pm 0.1 \times 10^{-6}$ of final frequency with reference after 1 hour on.
Phase Noise	Phase Noise @ 25°C		-105		dBc/Hz	10Hz
			-135			100Hz
			-160			1KHz
			-165			10KHz
			-170			100KHz
			-170			1MHz
Environmental Conditions	Operable Temperature	-40		+85	$^{\circ}\text{C}$	
	Storage Temperature	-55		+105	$^{\circ}\text{C}$	
	ESD Level	Human Body Model, class2: 2000V to 4000V; ANSI/ESDA/JEDEC JS-001-2010.				
		Machine Model, class B: 200V to 400V; JEDEC JESD22-A115C.				
	Moisture Sensitivity Level	Level 3.				
	RHOS	Products comply with ROHS 6.				
	Vibration	Test Condition: 0.75mm ;acceleration:10g;10Hz~500Hz, one cycle per 30 min, test 2 hour. (3 times for each 3 directions X , Y , Z), IEC 68-2-06 Test Fc.				
Shock	50g; 11ms; half sine wave (3 times for each 3 directions X , Y , Z),IEC 68-2-27 Test Ea/Severity 50A.					
Full Package Storage	Relative humidity (%)	20% ~ 70%				
	Temperature ($^{\circ}\text{C}$)	-10~ 35°C				



2. Mechanical Structure(mm)

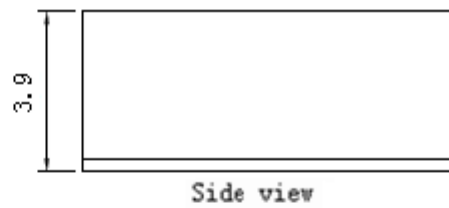
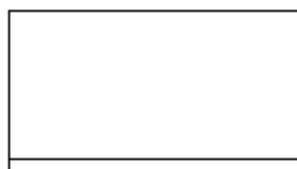
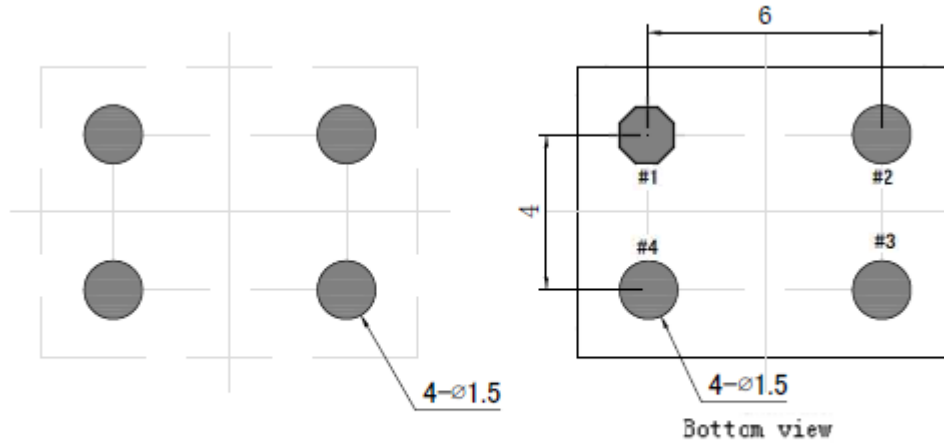

Pin Function	
Pin	Function
1	NC
2	GND
3	OUTPUT
4	VCC

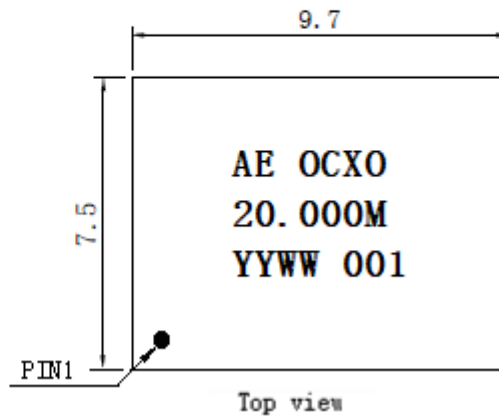

Note1: Tolerance $\pm 0.2\text{mm}$ without mark

Note2: YYWW is the year and week code and 001 indicates serial number and it will be 001, 002, 003,...

Note3: Referential Weight 0.4g

Note4: NC is not connect

Note5: 转换板激光二维码需除标，不允许出现激光二维码。



3. Test Circuit

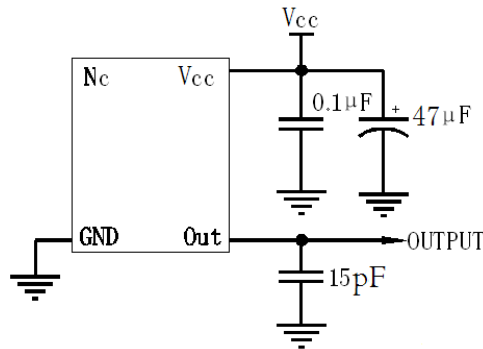

4. Reflow Soldering Curve (RoHS)

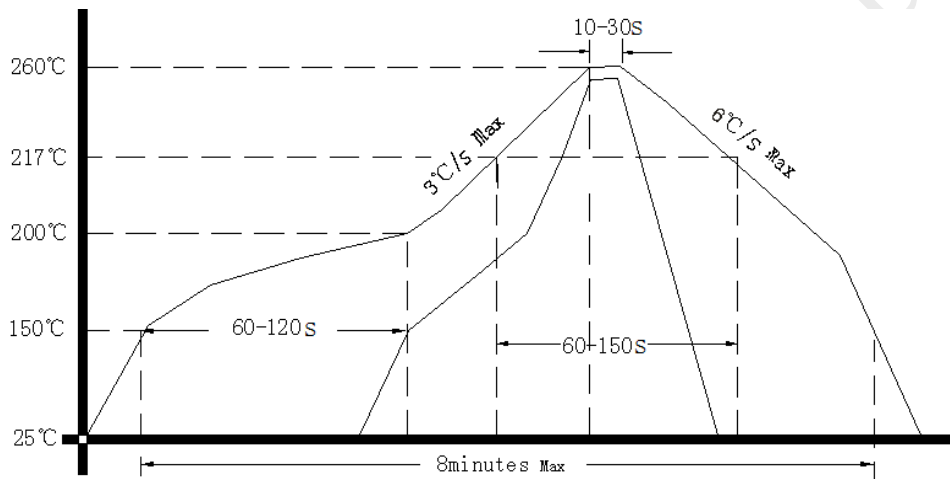

5. Package: Tape & Reel (mm)

