

Travelling Merchant: \_\_\_\_\_

# DATASHEET

Standard: **O75A-S319-12.80MHz-A198**

P/N: \_\_\_\_\_

Plot			The Label
Drew	Audited	Approved	Stamp, please! Thanks!
Date: 2024.05.11			

## Guangdong Dapu Telecom Technology Co.,Ltd

Building 5, No.24, Industrial East Road, Songshanhu Park, Dongguan, Guangdong, P.R. China

TEL: 0086-0769-88010888 FAX: 0086-0769-81800098





## 1、Electrical Parameters

MODEL: O75A-S319-12.80MHz-A198							
Item	Description	Parameters			Unit	Test Condition	
		Min.	Typ.	Max.			
Output	Frequency	12.80			MHz		
	Output Waveform	HCMOS					
	Output Low Voltage			0.4	V	$V_{cc}=3.3V, O_{load}=15pF$	
	Output High Voltage	2.7			V	$V_{cc}=3.3V, O_{load}=15pF$	
	Duty Cycle	45	50	55	%	@50%	
	Rise / Fall Time (10%~90%)			10	ns		
	Load	15			pF		
Frequency Stabilities	Frequency Tolerance vs. Operating Temperature Range	-0.02		+0.02	$\times 10^{-6}$	$T_A$ varied from $-40^{\circ}C$ to $85^{\circ}C$ , measurement referenced to frequency observed with $f_{ref} = (f_{max}+f_{min})/2$ , $V_{cc}=3.3V, O_{load}=15pF$ , temperature variable speed less than $2^{\circ}C$ per minute, in a windless environment.	
	Initial Frequency Tolerance	-1		+1	$\times 10^{-6}$	Measurement referenced to frequency observed with $T_A = 25^{\circ}C, V_{cc}=3.3V$ , and after 15 minutes of operation, Within 24 hours after ex-works.	
	Frequency Tolerance vs. Supply Voltage	-3		+3	$\times 10^{-9}$	measurement referenced to frequency observed $T_A=25^{\circ}C, V_{cc}$ varied from 3.13V to 3.47V, and $O_{Load}= 15pF$ .	
	Frequency Tolerance vs. Load	-3		+3	$\times 10^{-9}$	5% load change measurement referenced to frequency observed with $T_A= 25^{\circ}C, V_{cc}=3.3V, O_{Load}= 15pF$ .	
	Short-Term Stability: Allan Variance				0.08	$\times 10^{-9}$	Temperature stability, no EMI/EMC or other interference, test after power for 1hour ref. to $25^{\circ}C$ ; 10s.
					0.1	$\times 10^{-9}$	Temperature stability, no EMI/EMC or other interference, test after power for 1hour ref. to $25^{\circ}C$ ; 100s.
	Aging Tolerance Per Day	-3		+3	$\times 10^{-9}$	$V_{cc}, T_A$ constant measurement referenced to frequency observed with $T_A=25^{\circ}C, V_{cc}= 3.3V$ , and after 30 days of operation.	
	Aging Tolerance 1 Year	-0.3		+0.3	$\times 10^{-6}$		
	Aging Tolerance 30 Days	-0.09		+0.09	$\times 10^{-6}$		
Aging Tolerance 20 Years	-3		+3	$\times 10^{-6}$			



	Holdover 24hours Drift	-3		+3	$\times 10^{-9}$	$V_{cc}=3.3V$ , temperature change range $\pm 2.8^{\circ}C$ , after 30 days of operation.
	Overall Stability	-4.6		+4.6	$\times 10^{-6}$	Inclusive of the following: - operating temperature $-40^{\circ}C$ to $85^{\circ}C$ - $3.3V \pm 5\%$ - 15pF load $\pm 5\%$ - 2 times reflow soldering - 20 years aging reference to nominal frequency
Stratum 3E compliant per GR-1244-CORE teleconcordia						
Power Supply	Supply Voltage	3.13	3.3	3.47	V	
	Steady Consumption			300	mA	@ $25^{\circ}C$
	Warm-Up Time			5	minutes	@ $25^{\circ}C$ within $\pm 0.1 \times 10^{-6}$ of final frequency with reference after 1 hour on.
	Warm up current			600	mA	
Phase Noise	Phase Noise		-112	-105	dBc/Hz	10Hz
			-142	-138		100Hz
			-158	-154		1KHz
			-160	-155		10KHz
			-160	-155		100KHz
Environmental Conditions	Operable Temperature	-40		+85	$^{\circ}C$	
	Storage Temperature	-55		+105	$^{\circ}C$	
	ESD Level	Human Body Model, class2: 2000V to 4000V; ANSI/ESDA/JEDEC JS-001-2010.				
		Machine Model, class B: 200V to 400V; JEDEC JESD22-A115C.				
	Moisture Sensitivity Level	Level 2.				
	Vibration	Test Condition: 0.75mm ;acceleration:10g;10Hz~500Hz, one cycle per 30 min, test 2 hour. (3 times for each 3 directions X , Y , Z), IEC 68-2-06 Test Fc.				
Shock	50g; 11ms; half sine wave (3 times for each 3 directions X , Y , Z ),IEC 68-2-27 Test Ea/Severity 50A.					
Full Package Storage	Relative humidity (%)	20%~70%				
	Temperature ( $^{\circ}C$ )	-10~35 $^{\circ}C$				



## 2、Mechanical Structure(mm)

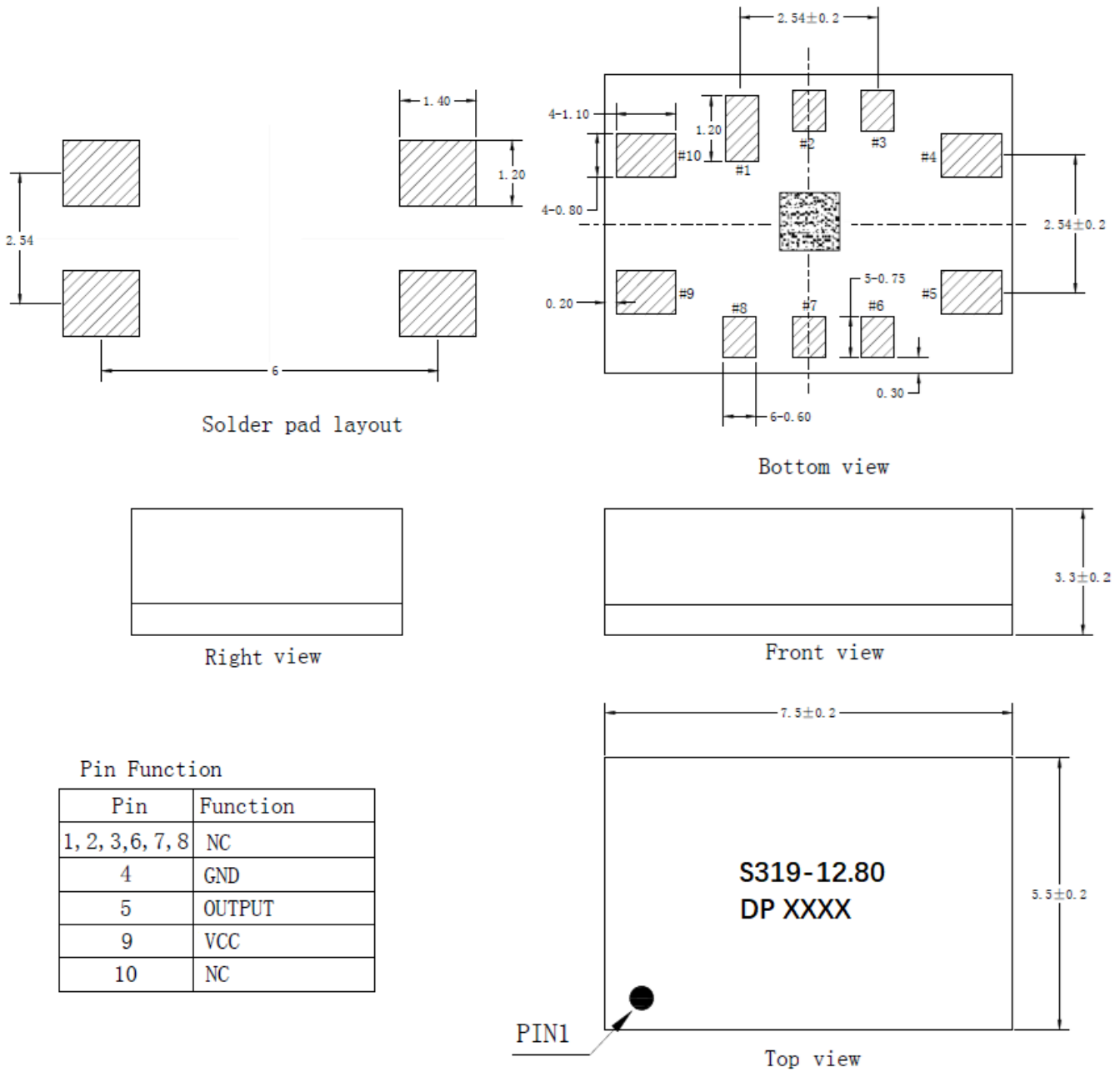

- Note1:** Tolerance  $\pm 0.2\text{mm}$  without mark
- Note2:** Referential weight 0.2g
- Note3:** NC is not connect
- Note4:** The first two xx representative: week  
After two xx representative: year



### 3、 Test Circuit

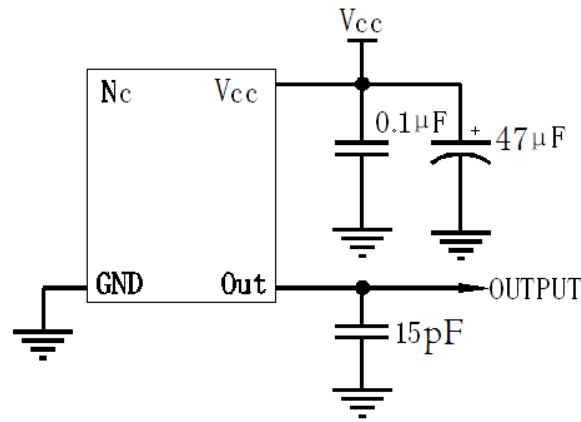

### 4、 Reflow Soldering Curve (RoHS)

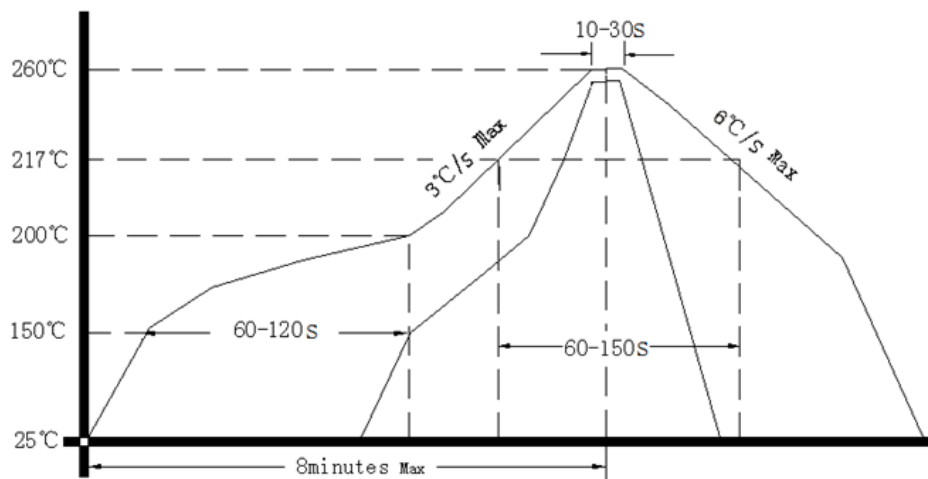

Note: Passing through reflow upside down is not supported

### 5、 Package (mm)

