

Travelling Merchant: _____

DATASHEET

Standard: **O23B-K327-10.00MHz**

Plot			The Label
Drew	Audited	Approved	Stamp, please! Thanks!
Date: 2021.09.13			

Guangdong Dapu Telecom Technology Co.,Ltd

Building 5, No.24, Industrial East Road, Songshanhu Park, Dongguan, Guangdong, P.R. China

TEL: 0086-0769-88010888 FAX: 0086-0769-81800098



1、Electrical Parameters

MODEL: O23B-K327-10.00MHz							
Item	Description	Parameters			Unit	Test Condition	
		Min.	Typ.	Max.			
Output	Frequency	10.00			MHz		
	Output Waveform	LVCMOS					
	Output Low Voltage			+0.3	V	V _{cc} =5.0V, O _{load} =15pF//10KΩ	
	Output High Voltage	+2.9			V	V _{cc} =5.0V, O _{load} =15pF//10KΩ	
	Duty Cycle	45	50	55	%	@50%	
	Rise / Fall Time			3	ns	10%~90%	
	Load	15pF//10KΩ					
Frequency Stabilities	Frequency Tolerance vs. Operating Temperature Range	-3		+3	ppb	T _A varied from -10°C to 75°C, measurement referenced to frequency observed with T _A = 25°C, V _{cc} =5.0V, V _C =2.5V, O _{load} =15pF//10KΩ, temperature rise speed less than 2°C per minute.	
	Initial Frequency Tolerance	-0.1		+0.1	ppm	Measurement referenced to frequency observed with T _A =25°C, V _{cc} =5.0V, V _C =2.5V, and after 15 minutes of operation, within 30 days after ex-works.	
	Frequency Tolerance vs. Supply Voltage	-0.3		+0.3	ppb	measurement referenced to frequency observed T _A =25°C, V _{cc} varied from 4.75V to 5.25V, V _C =2.5V and O _{Load} =15pF//10KΩ.	
	Frequency Tolerance vs. Load	-0.3		+0.3	ppb	10% load change measurement referenced to frequency observed with T _A = 25°C, V _{cc} =5.0V, V _C =2.5V.	
	Short-Term Stability: Allan Variance				0.01	ppb	Temperature stability, no EMI\EMC or other interference, test after power for 1hour ref. to 25°C; 1s.
					0.05	ppb	Temperature stability, no EMI\EMC or other interference, test after power for 1hour ref. to 25°C; 100s.
	Power-on frequency accuracy	-0.02		+0.02	ppm	V _c =2.5V, @25°C, power-on for 8 minutes.	
	Aging Tolerance Per Day	-0.3		+0.3	ppb	V _{cc} , V _C , T _A constant measurement referenced to frequency observed with T _A = 25°C, V _{cc} = 5.0V, V _C =2.5V, and after 30 days of operation.	
	Aging Tolerance 1 Year	-0.05		+0.05	ppm		
	Aging Tolerance 10 Years	-0.3		+0.3	ppm		
	Aging Tolerance 15 Years	-0.4		+0.4	ppm		



Power Supply	Supply Voltage	4.75	5.0	5.25	V	
	Current Consumption			400	mA	@25°C
	Current Consumption during warm up			750	mA	
Voltage Control Characteristics	Frequency Tuning Range	-1		-0.8	ppm	V _C = 0 V. measurement referenced to V _C =2.5V
		-0.1		+0.1	ppm	V _C =2.5V. measurement referenced to exactly 10.00MHz
		+0.8		+1	ppm	V _C =5.0V. measurement referenced to V _C =2.5V
	Linearity			10	%	
	Slope	Positive				
	Input Impedance	100			K Ohm	
	Modulation Band Width	10			KHz	
Phase Noise	Phase Noise		-90		dBc/Hz	1Hz
			-120			10Hz
			-140			100Hz
			-145			1KHz
			-150			10KHz
			-150			100KHz
Environmental Conditions	Operable Temperature	-40		+75	°C	
	Storage Temperature	-55		+85	°C	
	Vibration	Test Condition: 0.75mm ;acceleration:10g;10Hz~500Hz, one cycle per 30 min, test 2 hour. (3 times for each 3 directions X ,Y , Z), IEC 68-2-06 Test Fc.				
	Shock	50g; 11ms; half sine wave (3 times for each 3 directions X ,Y , Z),IEC 68-2-27 Test Ea/Severity 50A.				



2、 Mechanical Structure(mm)

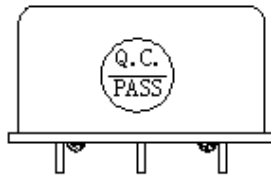
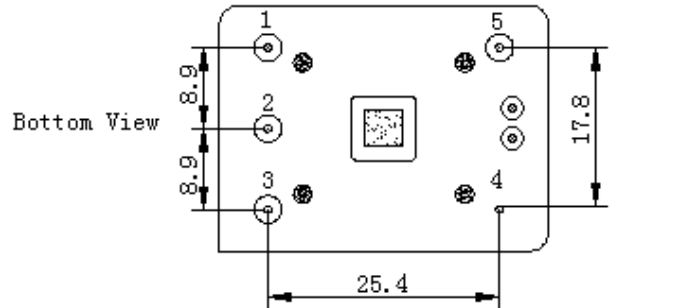

Right View

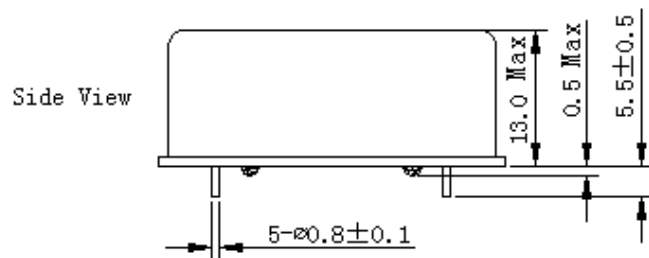

Side View

PIN FUNCTION

PIN	FUNCTION
1	VCC
2	NC
3	VC
4	GND
5	OUTPUT

*Tolerance ±0.2mm without mark

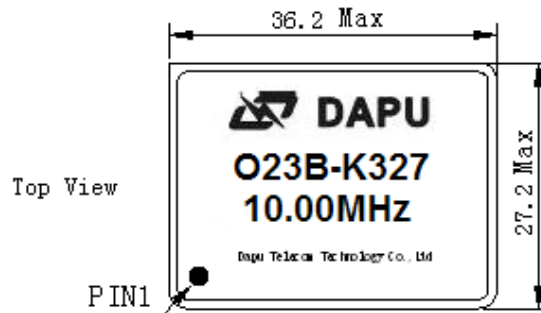

Top View

Note1: Referential Weight 21.0g



3、 Test Circuit

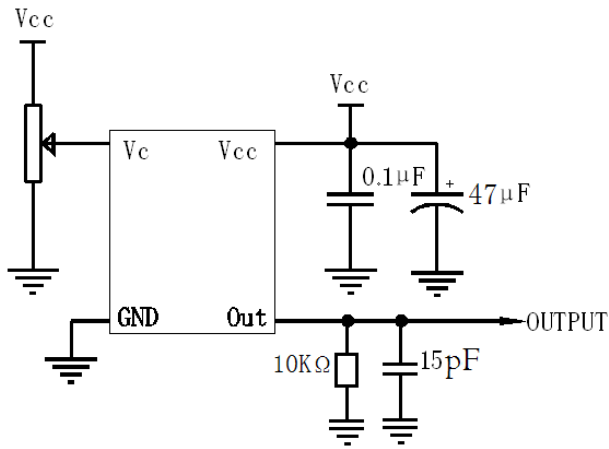

4、 Wave Soldering Curve (RoHS)

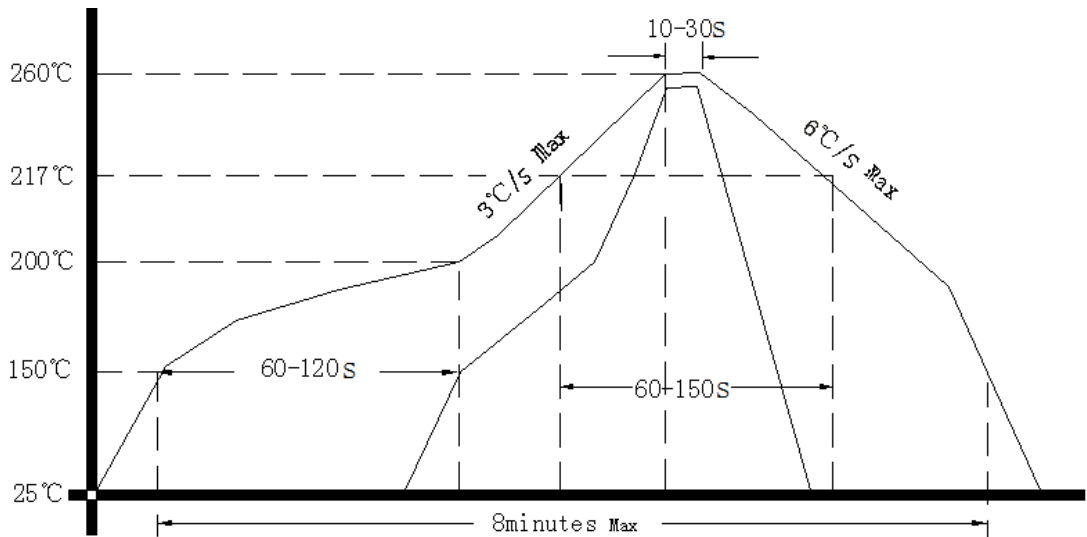

5、 Package (mm)

