

Customer Code: _____

DATASHEET

DAPU P/N: **O22B-F445-10.00MHz-ACT**

Customer P/N: _____

DAPU			Customer Approval
Drew	Audited	Approved	Stamp, please! Thanks!
Date: 2023.10.11			

Guangdong Dapu Telecom Technology Co.,Ltd

Building 5, No.24, Industrial East Road, Songshanhu Park, Dongguan, Guangdong, P.R. China

TEL: 0086-0769-88010888 FAX: 0086-0769-81800098



1. Electrical Parameters

MODEL: O22B-F445-10.00MHz-ACT						
Item	Description	Parameters			Unit	Test Condition
		Min.	Typ.	Max.		
Output	Frequency	10.00			MHz	
	Output Waveform	Sine wave				
	Level	8			dBm	
	Load	50			Ω	
	Harmonics Suppression			-30	dBc	
	Spurious Suppression			-80	dBc	10Hz to 1MHz from carrier
Frequency Stabilities	Frequency Tolerance vs. Operating Temperature Range	-5		+5	$\times 10^{-9}$	T_A varied from 0°C to 70°C, measurement referenced to frequency observed with $f_{ref}=(f_{max}+f_{min})/2$, $V_{cc}=12V$, $O_{load}=50\Omega$, temperature variable speed less than 2°C per minute.
	Initial Frequency Tolerance	-0.2		+0.2	$\times 10^{-6}$	Measurement referenced to frequency observed with $T_A=25^\circ C$, $V_{cc}=12V$, $V_c=2.5V$, and after 15 minutes of operation, within 30 days after ex-works.
	Frequency Tolerance vs. supply voltage	-0.5		+0.5	$\times 10^{-9}$	5% voltage change measurement referenced to frequency observed $T_A=25^\circ C$, $V_c=2.5V$, $O_{load}=50\Omega$.
	Frequency Tolerance vs. Load	-0.5		+0.5	$\times 10^{-9}$	5% load change measurement referenced to frequency observed with $T_A=25^\circ C$, $V_{cc}=12V$, $V_c=2.5V$, $O_{load}=50\Omega$.
	Short-Term Stability: Allan Variance		0.002		$\times 10^{-9}$	Temperature stability, no EMI\EMC or other interference, test after power for 1hour ref. to 25°C; 1s.
	Aging Tolerance Per Day	-0.5		+0.5	$\times 10^{-9}$	V_{cc} , V_c , T_A constant measurement referenced to frequency observed with $T_A=25^\circ C$, $V_{cc}=12V$, $V_c=2.5V$, and after 30 days of operation..
	Aging Tolerance Per Year	-0.05		+0.05	$\times 10^{-6}$	
	Aging Tolerance 10Years	-0.3		+0.3	$\times 10^{-6}$	



Power Supply	Supply Voltage	10.35	12.0	12.65	V	
	Steady Consumption			200	mA	@25°C
	Warm up current			400	mA	
	Warm-Up Time			5	min	@25 °C within $\pm 0.05 \times 10^{-6}$ power on 5 minutes referred to 1 hour
Voltage Control Characteristics	Frequency Tuning Range			-0.4	$\times 10^{-6}$	$V_c=0V$. measurement referenced to $V_c=2.5V$
		-0.2		+0.2	$\times 10^{-6}$	$V_c=2.5V$. measurement referenced to exactly 10.00MHz
		+0.4			$\times 10^{-6}$	$V_c=5V$. measurement referenced to $V_c=2.5V$
	Linearity			10	%	
	Slope	Positive				
	Input Impedance	100			K Ω	
Phase Noise	Phase Noise @25°C			-100	dBc/Hz	1Hz
				-130		10Hz
				-145		100Hz
				-155		1KHz
				-155		10KHz
Environmental Conditions	Operating Temperature	0		+70	°C	
	Storage Temperature	-55		+105	°C	
	ESD Level	Human Body Model, class2: 2000V to 4000V; ANSI/ESDA/JEDEC JS-001-2010.				
		Machine Model, class B: 200V to 400V; JEDEC JESD22-A115C.				
	Moisture Sensitivity Level	Not humidity sensitive.				
	Vibration	Test Condition: 0.75mm ;acceleration:10g;10Hz~500Hz, one cycle per 30 min, test 2 hour. (3 times for each 3 directions X , Y , Z), IEC 68-2-06 Test Fc.				
	Shock	50g; 11ms; half sine wave (3 times for each 3 directions X , Y , Z),IEC 68-2-27 Test Ea/Severity 50A.				
Full Package Storage	Relative humidity (%)	20% ~70%				
	Temperature (°C)	-10~35°C				



2. Mechanical Structure (mm)

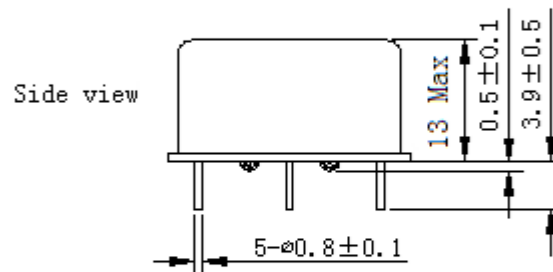
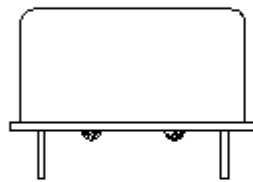
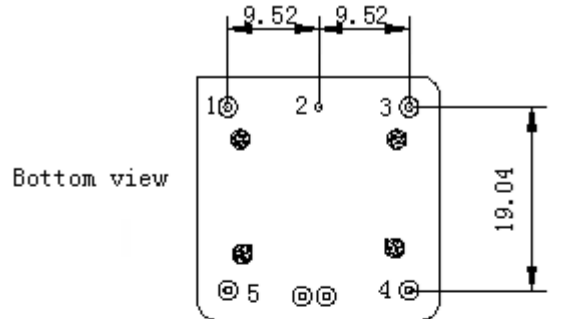

PIN FUNCTION

PIN	NOTATION	FUNCTION
1	OUTPUT	RF Output
2	GND	GND
3	VC	Control Voltage
4	NC	Not Connect
5	VCC	Supply Voltage

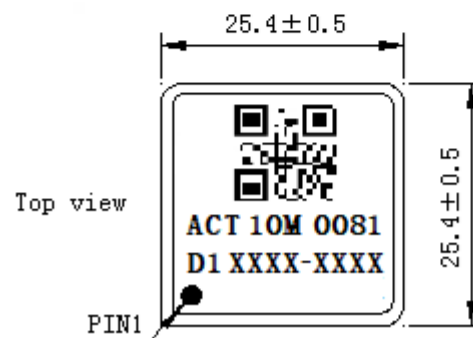

- Note1:** Tolerance $\pm 0.2\text{mm}$ without mark
Note2: Referential weight 13.6g
Note3: The first two xx representative: week
 After two xx representative: year
 At last four xxxx representative: serial number



3. Test Circuit

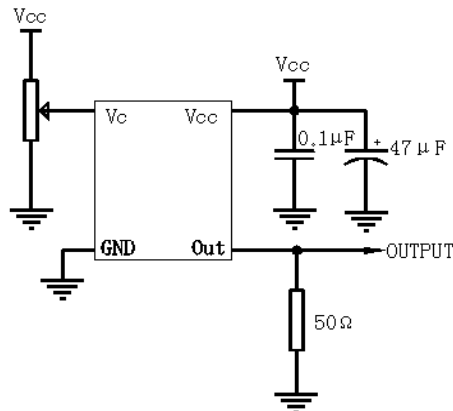

4. Reflow Soldering Curve (RoHS)

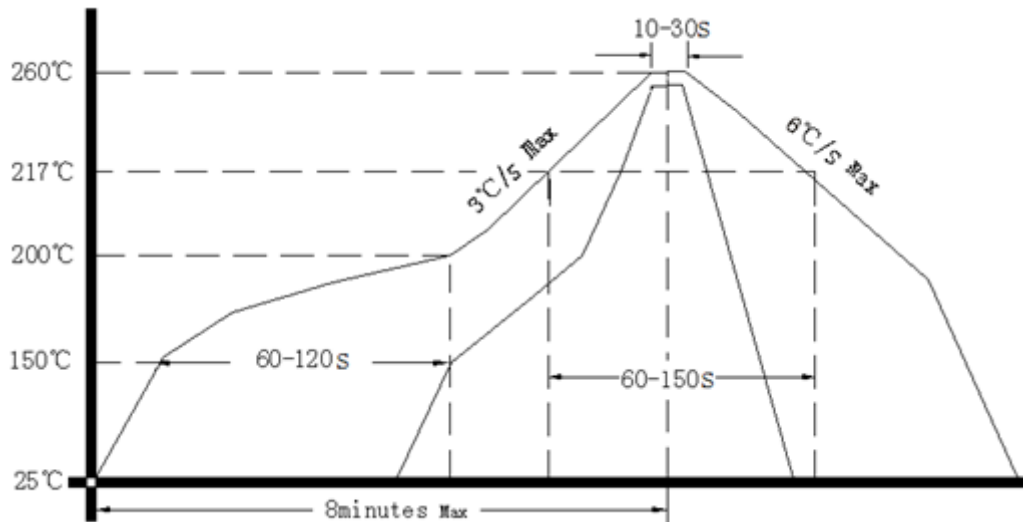

5. Package: Tape & Reel (mm)

