

Travelling Merchant: _____

DATASHEET

Standard: **O75A-2601-48.00MHz**

P/N: _____

Plot			The Label
Drew	Audited	Approved	Stamp, please! Thanks!
Date: 2025.03.12			

Guangdong Dapu Telecom Technology Co.,Ltd

Building 5, No.24, Industrial East Road, Songshanhu Park, Dongguan, Guangdong, P.R. China

TEL: 0086-0769-88010888 FAX: 0086-0769-81800098



Table of amendment

Version	Revision contents	Prepared by	Revised date
1.0	The first issued	<i>Amway</i>	2023.05.12
1.1	Add "Short-Term Stability: Allan Variance"	<i>Amway</i>	2024.04.02
1.2	The "Frequency Tolerance vs. Operating Temperature Range" "Enable Voltage" "Disable Voltage" changed	<i>Amway</i>	2024.04.24
1.3	The "Enable Voltage (High)" "Disable Voltage (low, open)" "Pin Function" changed	<i>Amway</i>	2024.05.15
1.4	The "Output High Voltage" "Marking" changed, Add "Short-Term Stability: Allan Variance"	<i>Amway</i>	2024.06.18
1.5	The "Enable Voltage (High, open)" "Disable Voltage (low)" "Pin Function" changed	<i>Amway</i>	2024.06.27
1.6	The "Output High Voltage" "Rise/Fall Time" "Aging" "Warm Up Time" "Phase Noise" "Enable Voltage (High, open)" "Disable Voltage (low)" "Mechanical Structure" changed, Add "Spurious Level During Vibration"	<i>Amway</i>	2025.03.12



1. Electrical Parameters

MODEL: O75A-2601-48.00MHz						
Item	Description	Parameters			Unit	Test Condition
		Min.	Typ.	Max.		
Output	Frequency	48.00			MHz	
	Output Waveform	LVCMOS				
	Output Low Voltage			0.4	V	$V_{cc}=3.3V, O_{load}=15\text{ pF}$
	Output High Voltage	2.4			V	$V_{cc}=3.3V, O_{load}=15\text{ pF}$
	Duty Cycle	45	50	55	%	@50%
	Rise/Fall Time (10%~90%)			3	ns	@25°C
	Load	15			pF	
Frequency Stabilities	Frequency Tolerance vs. Operating Temperature Range	-0.02		+0.02	$\times 10^{-6}$	T_A varied from -40°C to 105°C, measurement referenced to frequency observed with $f_{ref}=(f_{max}+f_{min})/2$, $V_{cc}=3.3V, O_{load}=15\text{ pF}$, temperature variable speed less than 2°C per minute.
	Initial Frequency Tolerance	-2		+2	$\times 10^{-6}$	Measurement referenced to frequency observed with $T_A=25^\circ\text{C}, V_{cc}=3.3V$ within 30 days after ex-works.
	Frequency Tolerance vs. Supply Voltage	-0.01		+0.01	$\times 10^{-6}$	measurement referenced to frequency observed $T_A=25^\circ\text{C}, V_{cc}$ varied from 3.13V to 3.47V, and $O_{Load}=15\text{ pF}$.
	Frequency Tolerance vs. Load	-0.01		+0.01	$\times 10^{-6}$	5% load change measurement referenced to frequency observed with $T_A=25^\circ\text{C}, V_{cc}=3.3V, O_{Load}=15\text{ pF}$.
	Frequency Slope	-1		+1	$\times 10^{-9}/^\circ\text{C}$	Temperature ramp $\leq 1^\circ\text{C}/\text{minute}$
	G-Sensitivity			1	$\times 10^{-9}/\text{g}$	Gamma vector of all three axes from 30Hz to 1500Hz
	Reflow Shift	-0.5		+0.5	$\times 10^{-6}$	After 1 hour at 25°C
	Short-Term Stability: Allan Deviation			0.02	$\times 10^{-9}$	Temperature stability, no EMI\EMC or other interference, test after power for 1 hour ref. to 25°C; 10ms
				0.05	$\times 10^{-9}$	Temperature stability, no EMI\EMC or other interference, test after power for 1 hour ref. to 25°C; 1s.
	Aging Tolerance Per Day	-3		+3	$\times 10^{-9}$	$T_A=25^\circ\text{C}, V_{cc}=3.3V$, and after 30 days of operation.
	Aging Tolerance 1 Year	-1		+1	$\times 10^{-6}$	
Aging Tolerance 10 Years	-3		+3	$\times 10^{-6}$		



	Enable Voltage (High, open)	1.7		3.3	V	Pin 8
	Disable Voltage (low)	-0.3		0.5	V	Pin 8
	Input Pull-up Impedance	10			kΩ	
	Steady Consumption			250	mA	@25°C
	Warm Up Current			600	mA	
	Supply Voltage	3.13	3.3	3.47	V	
	Warm Up Time			1	min	@25°C within $\pm 0.1 \times 10^{-6}$ of final frequency with reference after 1 hour on.
Phase Noise	Phase Noise (over full temp)		-70	-65	dBc/Hz	1Hz
			-102	-99		10Hz
			-135	-130		100Hz
			-155	-150		1KHz
			-161	-155		10KHz
			-161	-155		100KHz
			-161	-155		1MHz
Spurious Level During Vibration	Spurious at offset from f_0 during vibration at 2g Vibration conditions: (sinus wave) Vibration in three perpendicular directions. 10 to 200Hz.			-46	dBc	10Hz
				-66		100Hz
				-72		200Hz
Environmental Conditions	Operable Temperature	-40		+105	°C	
	Storage Temperature	-55		+105	°C	
	ESD Level	Human Body Model, class2: 2000V to 4000V; ANSI/ESDA/JEDEC JS-001-2010.				
		Machine Model, class B: 200V to 400V; JEDEC JESD22-A115C.				
	Moisture Sensitivity Level	Level 3.				
	Vibration	Test Condition: 0.75mm ;acceleration:10g;10Hz~2000Hz, one cycle per 30 min, test 2 hour. (3 times for each 3 directions X ,Y , Z) .IEC 68-2-06 Test Fc.				
Shock	100g; 6ms; half sine wave (3 times for each 3 directions X ,Y , Z) ,IEC 68-2-27 Test Ea/Severity 50A.					



2. Mechanical Structure(mm)

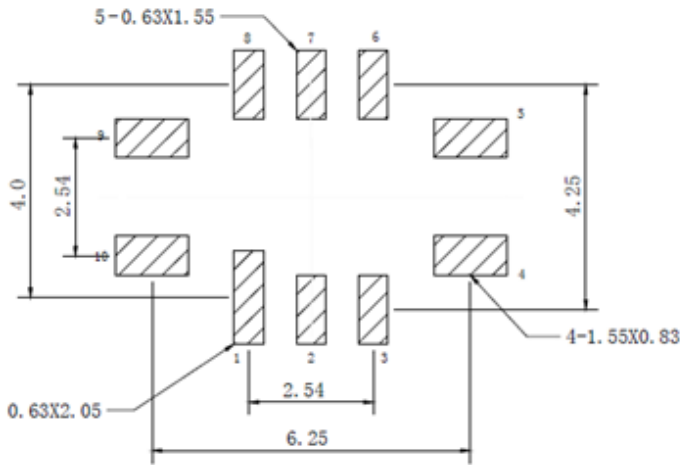

Solder pad layout



Right view

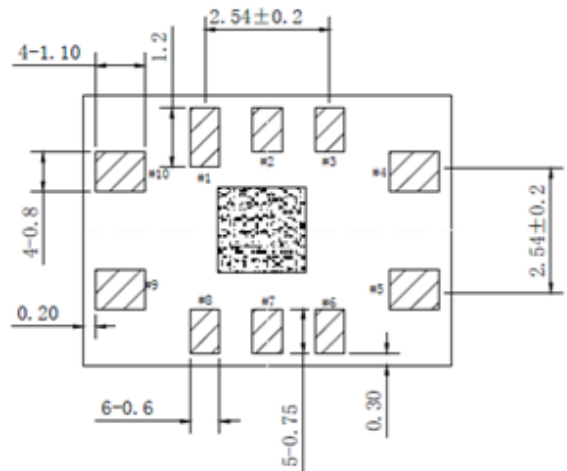

Bottom view



Front view

3.3±0.3

Pin Function

Pin	Function
1,2,3,6,7,10	NC
4	GND
5	OUTPUT
8	E/D
9	VCC

E/D	OUT
High Level ,Open	Data
Low Level	No Data

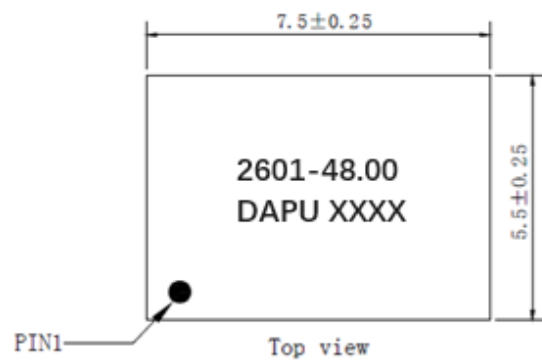

Top view

Note1: Tolerance $\pm 0.2\text{mm}$ without mark

Note2: The first two xx representative: year

After two xx representative: week

Note3: Referential Weight 0.2g

Note4: NC is not connect



3. Application environment recommendation

- a. In order to get better frequency stability and reduce frequency fluctuation of OCXO, it is suggested to use the product in wind-free environment.
- b. When designing the structure layout, it is recommended that the OCXO shell and other structural devices (such as heat sink, chassis frame, etc.) have a space distance of more than 10 mm, so as to avoid serious heat dissipation caused by the distance from OCXO shell, which will affect the performance.
- c. When PCB layout is in contact with the bottom of OCXO, the layout layer shall not be covered with copper and wiring in large area. The recommended layout is as follows:

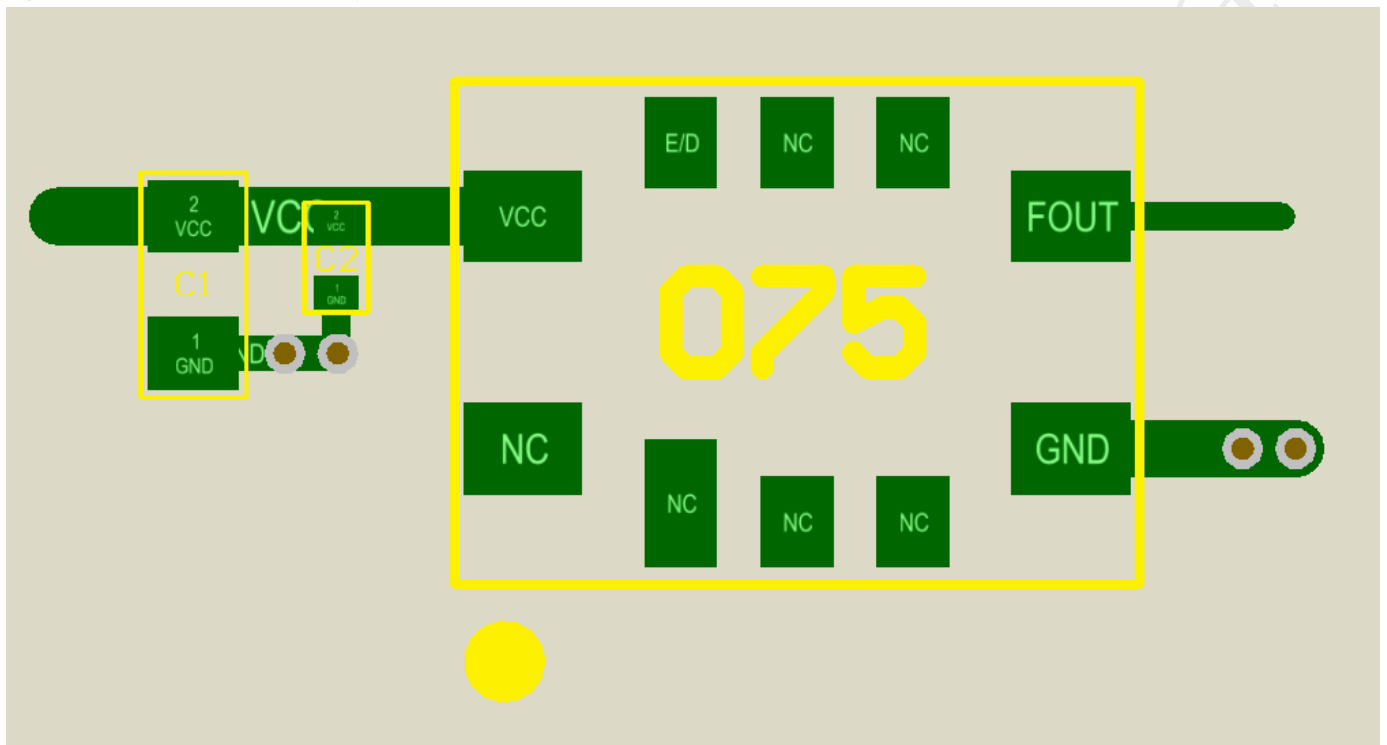

4. Test circuit

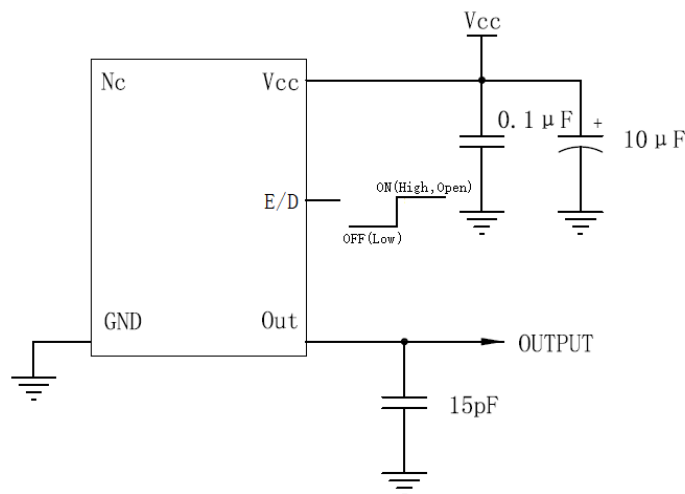



5. Reflow Soldering Curve (RoHS)

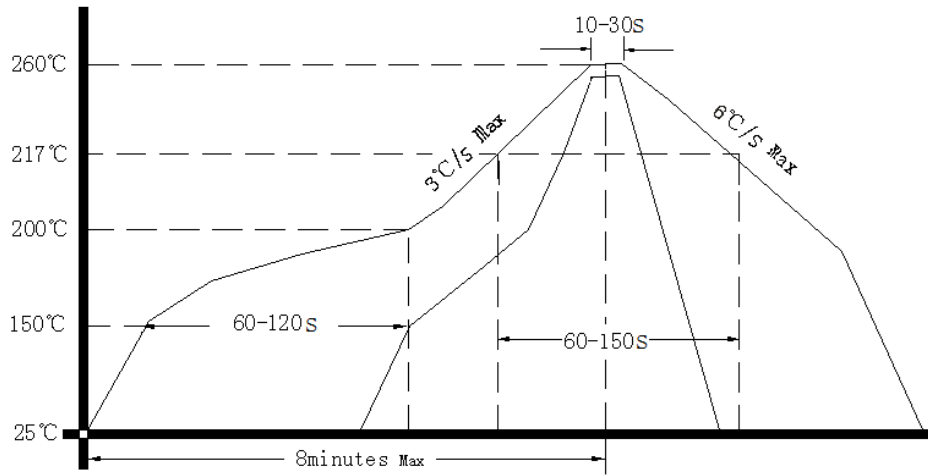

6. Package: Tape & Reel (mm)

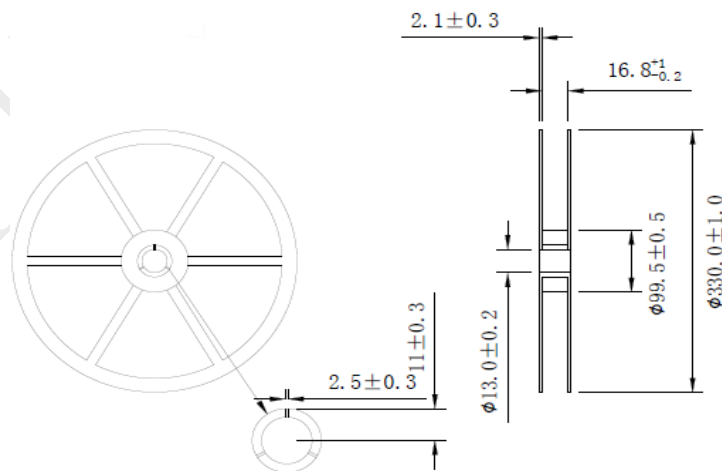
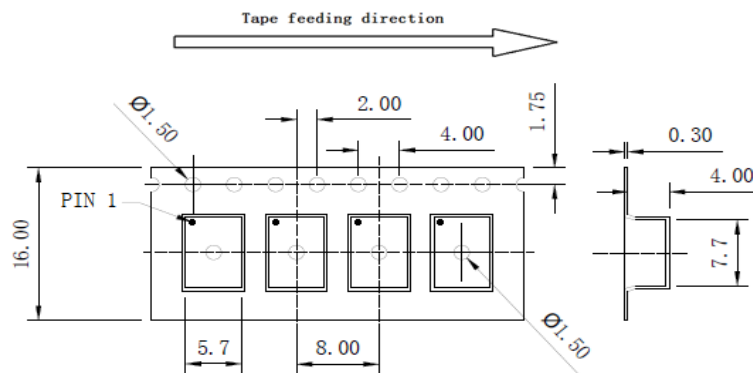

2000PCS/Reel
Material:HIPS (475)